

Protocol of the intercomparison at INTA, El Arenosillo, Spain on  
September 07 to 13, 2009 with the travelling reference  
spectroradiometer QASUME<sup>†</sup> from PMOD/WRC

Report prepared by Gregor Hülsen

Operator: Gregor Hülsen, Julian Gröbner

The purpose of the visit was the comparison of spectral global solar irradiance measurements between the 17 spectrophotometers participating in the 4<sup>th</sup> Regional Brewer Calibration Center – Europe (RBCC-E) Campaign (see Figure 1 and Table 1) and the travel reference spectroradiometer QASUME. The measurement site is located at El Arenosillo; Latitude 37.10 N, Longitude 6.73 W and altitude 50 m.a.s.l.

The horizon of the measurement site is free down to at least 85° solar zenith angle (SZA). Measurements between 5:00 UT and 18:00 UT have been analysed.

QASUME arrived at INTA in the morning of September 07, 2007. The spectroradiometer was installed in line to the Brewer spectrophotometers with the entrance optic of QASUME between 2 and 20 m away from the other instruments. The measurement campaign lasted seven days, from noon of September 07 to the evening of September 13; the core comparison days were September 12 and 13.

QASUME was calibrated several times during the intercomparison period using a portable calibration system. Three lamps (T68522, T68523, and T61251) were used to obtain an absolute spectral irradiance calibration traceable to the primary reference held at PMOD/WRC, which is traceable to PTB. The daily mean responsivity of the instrument based on these calibrations varied by less than 1 % during the intercomparison period. The internal temperature of QASUME was  $26.0 \pm 0.1$  °C. The diffuser head was heated to a temperature of  $29.6 \pm 2.2$  °C.

The wavelength shifts relative to an extraterrestrial spectrum as retrieved from the SHICRivm analysis were between  $\pm 50$  pm in the spectral range 290 to 400 nm.

---

<sup>†</sup> The QASUME spectroradiometer B5503 is made available by the Physical and Chemical Exposure Unit of the Joint Research Centre of the European Commission, Ispra, Italy through a collaboration agreement with PMOD/WRC.

**Table 1: Participating Brewer spectrophotometers; 8 single and 9 double monochromators.**

Instrument ID	Institution	Operator	Country
#017-MKII	IOS	Ken Lamb	Canada
#051-MKIV	DMN	Zaydi Mustapha	Morocco
#070-MKIV	AEMET MADRID	María Lopez	Spain
#075-MKIV	UKMO	Andrew Smedley	U.K.
#117-MKIV	INM MURCIA	Jose Antonio Parodi	Spain
#126-MKII	UKMO	Andrew Smedley	U.K.
#145 MKIII	MSC	Tom McElroy	Canada
#150-MKIII	INTA HUELVA	Jose Manuel Vilaplana	Spain
#151-MKIV	AEMET CORUÑA	Francisco García	Spain
#158-MKIII	Kipp & Zonen	Kristian Boot	The Netherlands
#163-MKIII (ISQ)	PMOD/WRC	Julian Gröbner	Switzerland
#165-MKIII	DMN	Zaidouni Taoufik	Morocco
#166-MKIV	AEMET MADRID	J.M. Santasnasio	Spain
#172-MKIII	UKMO	Andrew Smedley	U.K.
#185-MKIII (IZ3)	AEMED IZAÑA	Alberto Redondas	Spain
#186-MKIII	AEMED MADRID	Jose Montero	Spain
#197-MKIII	CMA	Zheng Xiangdong	China

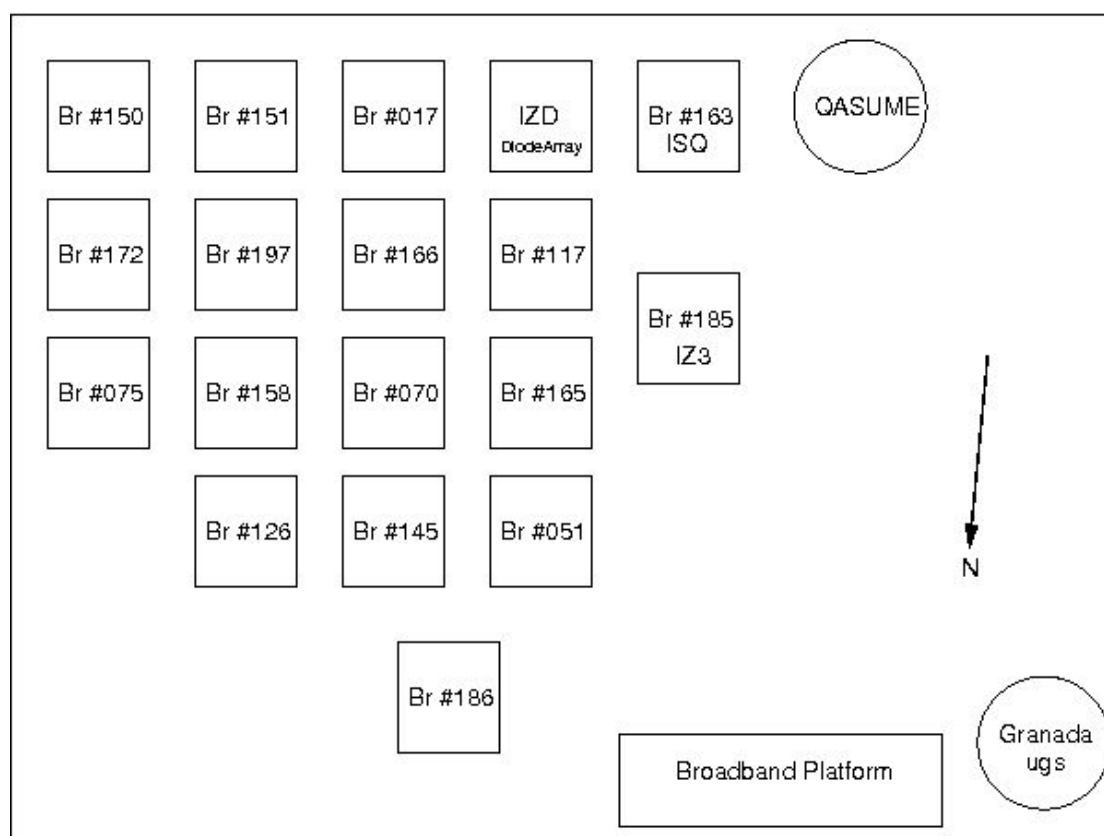
**Figure 1: Roof setup at INTA**

**Protocol:**

The measurement protocol was to measure one solar irradiance spectrum every 30 minutes from 290 to 400 nm, every 0.5 nm, and 3 seconds between each wavelength increment.

DOY	Date	DAY	Weather	Comment
250	7-Sep	Monday	Mix of sun & clouds hazy	Installed at 7:00 UT
251	8-Sep	Tuesday	Mix of sun & clouds hazy	Calibrated: 11:40 using T68523
252	9-Sep	Wednesday	Mix of sun & clouds hazy	
253	10-Sep	Thursday	Mix of sun & clouds hazy	Calibrated: 7:15 using T68523
254	11-Sep	Friday	Mix of sun & clouds hazy	Calibrated: 6:50 using T68523
255	12-Sep	Saturday	Mostly clear sky	UV Days Calibrated: 7:15 using T68523
256	13-Sep	Sunday	Mostly clear sky Clouds at the horizon	UV Days Calibrated: 16:15 using T68523 Calibrated: 16:35 using T68523 Calibrated: 17:12 using T61251  End of Campaign: 18:15 UT

**Results:**

In total 30 to 113 synchronised simultaneous spectra from QASUME and the Brewer spectrophotometers are available from the measurement period. Measurements between 6:30 and 18:30 UT have been analysed (SZA smaller than 90°).

**Remarks:**

1. The first day of the intercomparison was dedicated to the setup and training phase. The official “UV-days” were 12 and 13 September (255-256). However, synchronized UV scans are also available from the start of the campaign.
2. Because of the different calibrations and measurements performed during the campaign, traffic on the roof could not be completely omitted. Therefore several scans are disturbed.
3. The time synchronisation between QASUME and various Brewers was much better than in the year 2007. However, in the beginning of the campaign the time lag was sometimes several minutes. UV measurements with differences of up to one minute were accepted as “synchronized” scans.

**Brewer Temperature Dependence:**

The standard Brewer global UV measurement procedure does not take into account the dependence of the Brewer spectral responsibility to ambient temperature. However several studies have shown, that Brewer spectrophotometers have a temperature dependence which can be as large as 0.9%/K and which depends on wavelength (Cappellani, F., and C. Kochler (2000), Temperature effects correction in a Brewer MKIV spectrophotometer for solar UV measurements, *J. Geophys. Res.*, 105(D4), 4829–4831; Weatherhead, E., et al. (2001), Temperature dependence of the Brewer ultraviolet data, *J. Geophys. Res.*, 106(D24), 34,121–34,129).

At El Arenosillo, due to the diurnal temperature variations, the temperature dependence of the Brewer spectrophotometers has a significant influence on the global UV measurements as can be seen in the respective ratios relative to the QASUME spectroradiometer which is temperature stabilised. The figures on page 89 to 96 show these ratios plotted as a function of the internal temperature of the Brewers. From this data, the temperature dependencies of the instruments can be derived using a linear fit (see table 2). Using these temperature correction factors the diurnal variations can be partly removed. This can be seen in the stable performance of Brewer #163, which can partly be explained by the applied temperature correction of -0.22%/K.

## **Recommendations:**

The variabilities observed between individual Brewer spectrophotometers relative to the QASUME spectroradiometer are due to ambient temperature variations on the one hand (see above paragraph), and to angular response errors which were not accounted for (See for example Gröbner, J., Improved entrance optic for global irradiance measurements with a Brewer spectrophotometer, Applied Optics, 42, 3516-3521, 2003). While a reliable correction of angular response errors requires the modification of the Brewer entrance optic, the temperature dependence can be corrected by applying a suitable spectral temperature correction to global UV measurements. The temperature correction factors derived from the diurnal variations of the ratios Brewer to QASUME (table 2) can only serve as an approximation because these variations do not only depend on the temperature. This function should therefore be determined individually for every Brewer using a measurement procedure as described in the refereed literature (see references).

**Table 2: Mean values of the ratio Brewer/QASUME (305 – 320 nm), the diurnal variability, the wavelength shifts and the Brewer temperature dependencies**

Instrument ID	Brewer to QASUME [%]	Diurnal variability [%]	Wavelength shift [pm]	Temperature Dependence [%/K]
#017	-10	±2	-5 .. +20	-0.28
#051	-8	±2	-20 .. +80	-0.38
#070	-9	±2	-10 .. +100	-0.28
#075	-4	±2	-120 .. -50	-0.23
#117	-6	±3	-20 .. +80	-0.45
#126	-8	±4	-50 .. +20	-0.46
#145	-4	±2	-10 .. +50	-0.41
#150	-1	±4	-40 .. -10	-0.53
#151	-6	±3	-60 .. +5	-0.53
#158	-1	±2	-50 .. +10	-0.31
#163 (ISQ)	2	±1	-30 .. -10	-0.15
#165	-9	±3	-40 .. -30	-0.43
#166	-10	±3	-50 .. +60	-0.48
#172	-6	±2	-5 .. +60	-0.19
#185 (IZ3)	-4	±3	-10 .. +50	-0.10
#186	-10	±2	-80 .. +40	-0.21
#197	4	±4	-80 .. +30	-0.46

UV Index INTA, September 2009

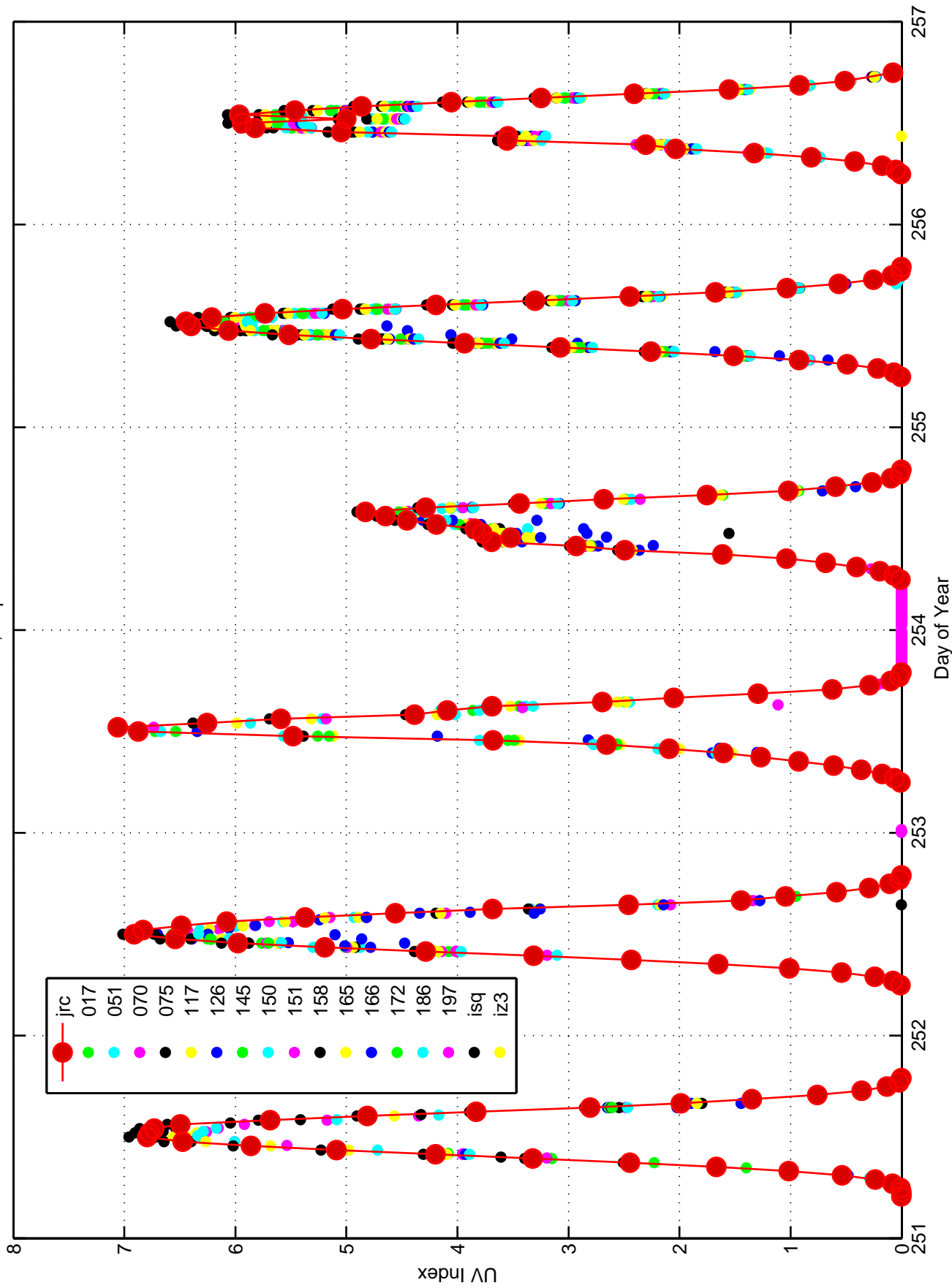

UV Index INTA, September 2009

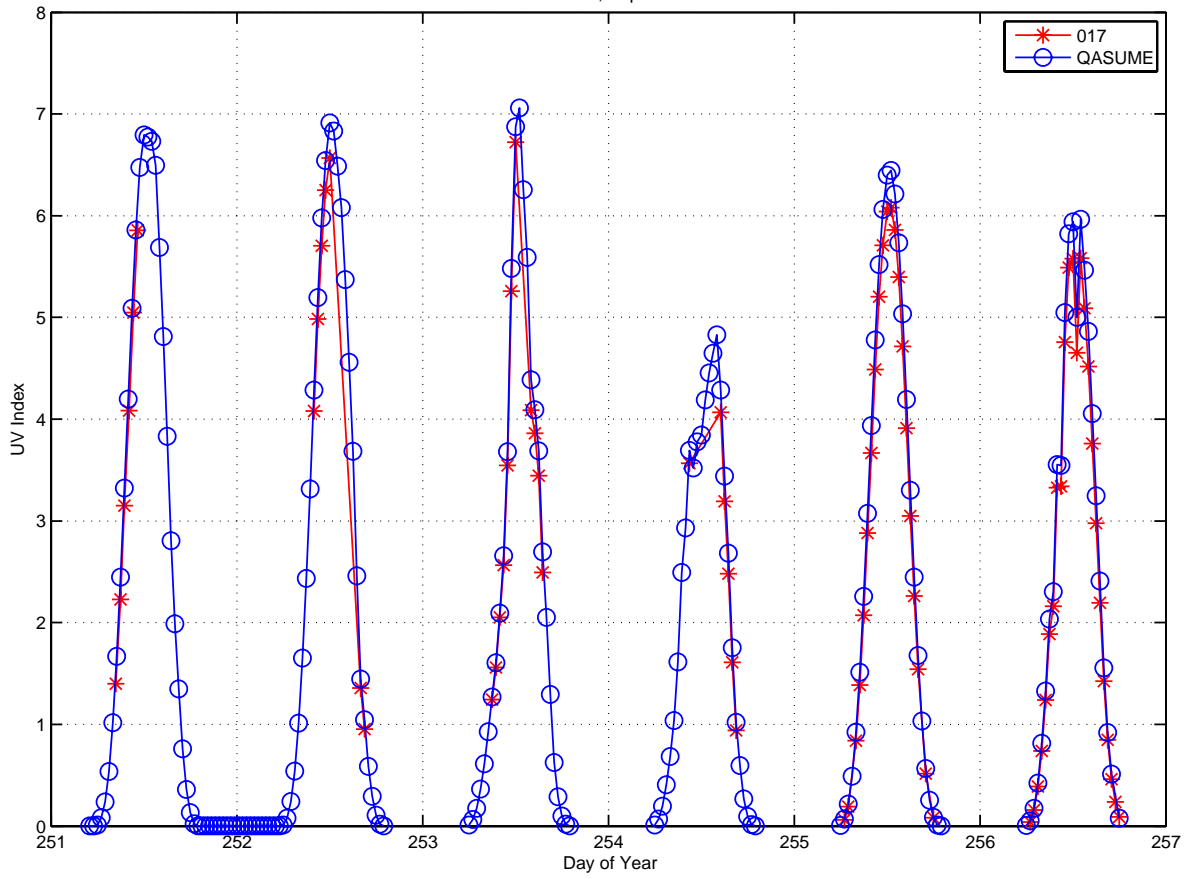

Global irradiance ratios 017/QASUME at INTA:08-Sep-2009(251) to 13-Sep-2009(256)

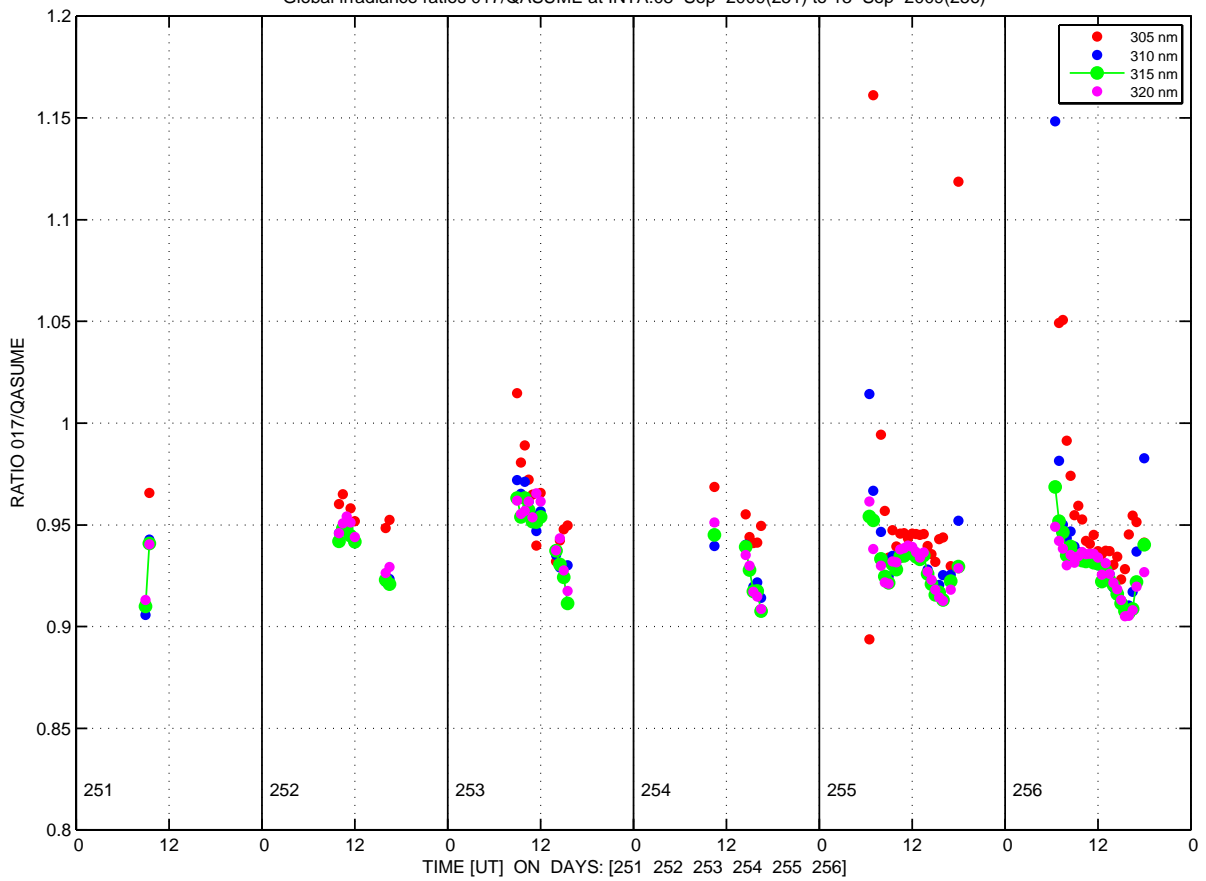

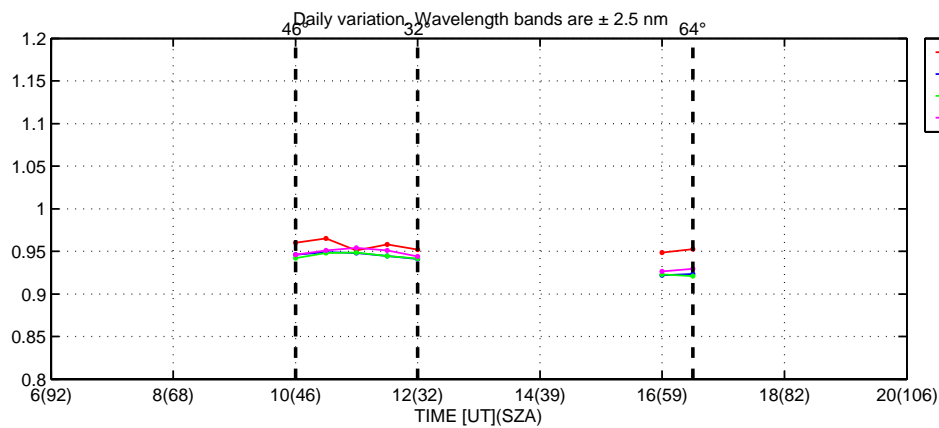
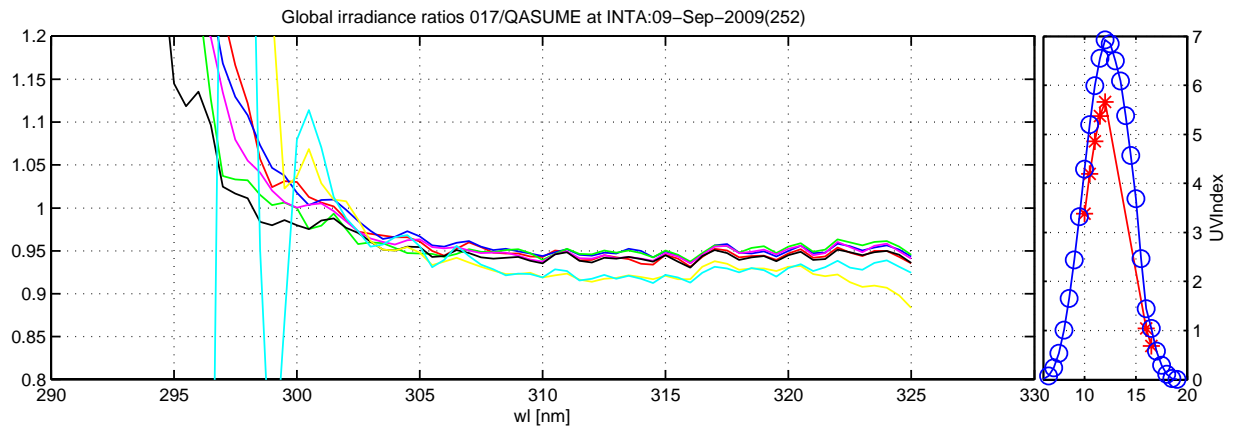
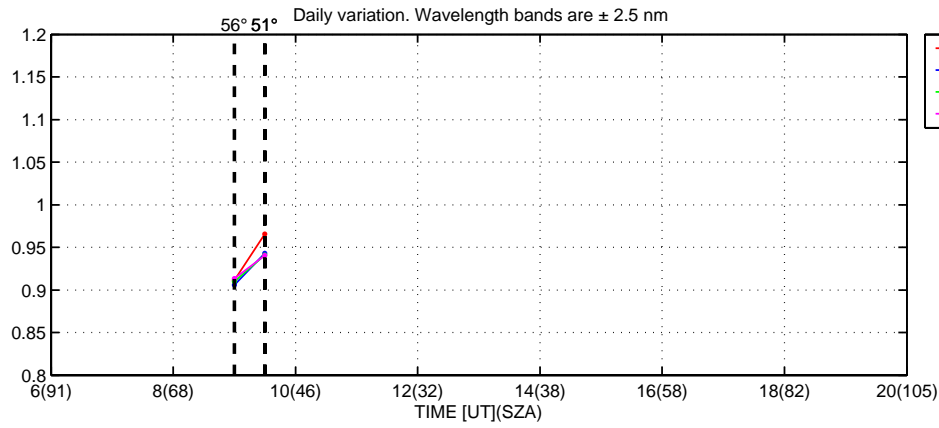
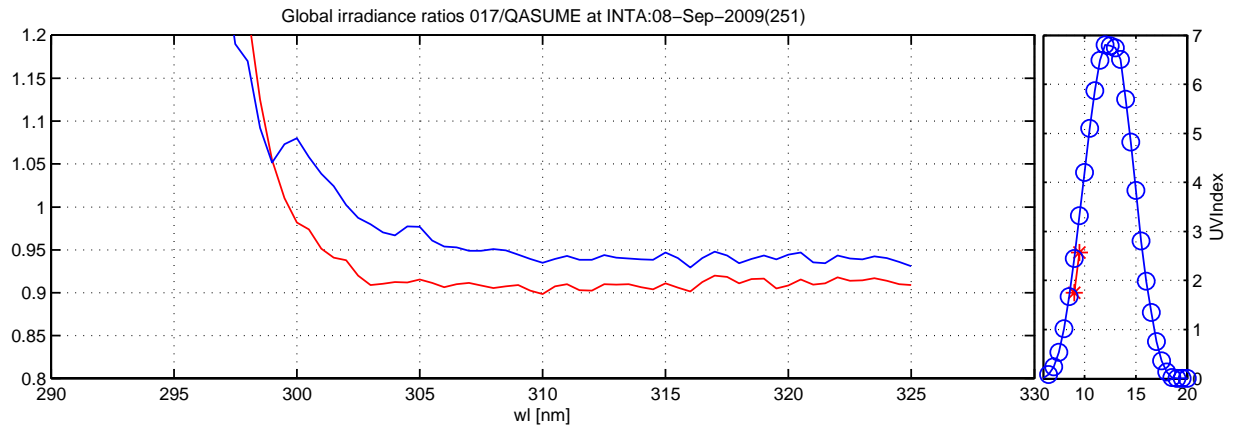



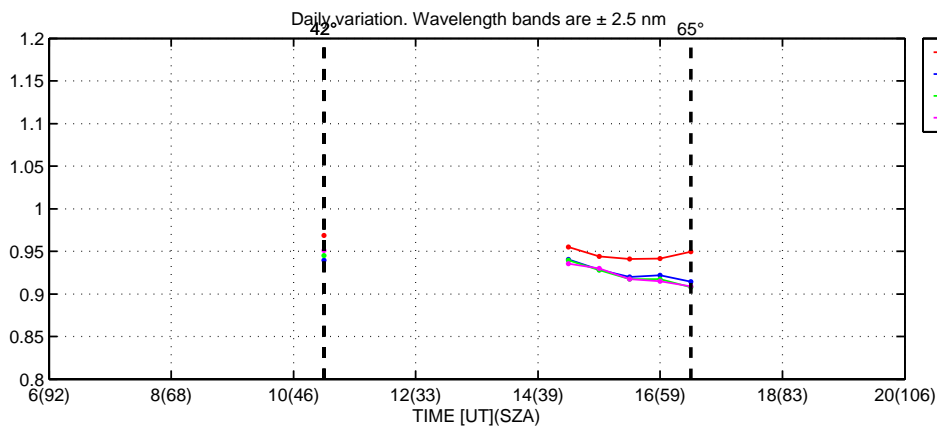
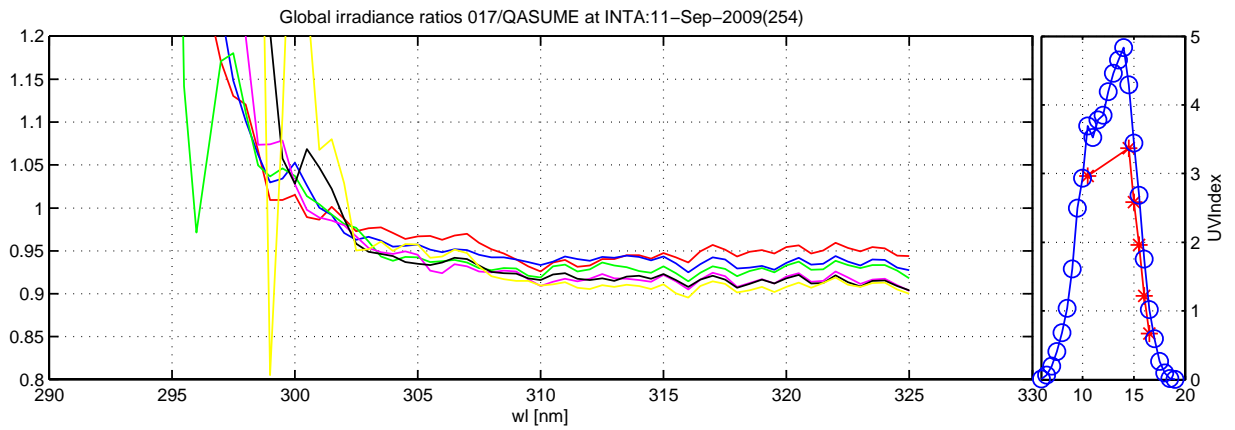
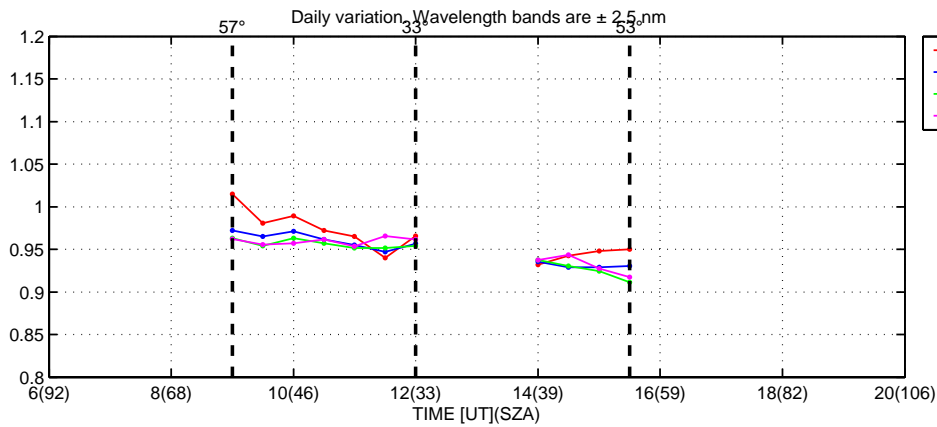
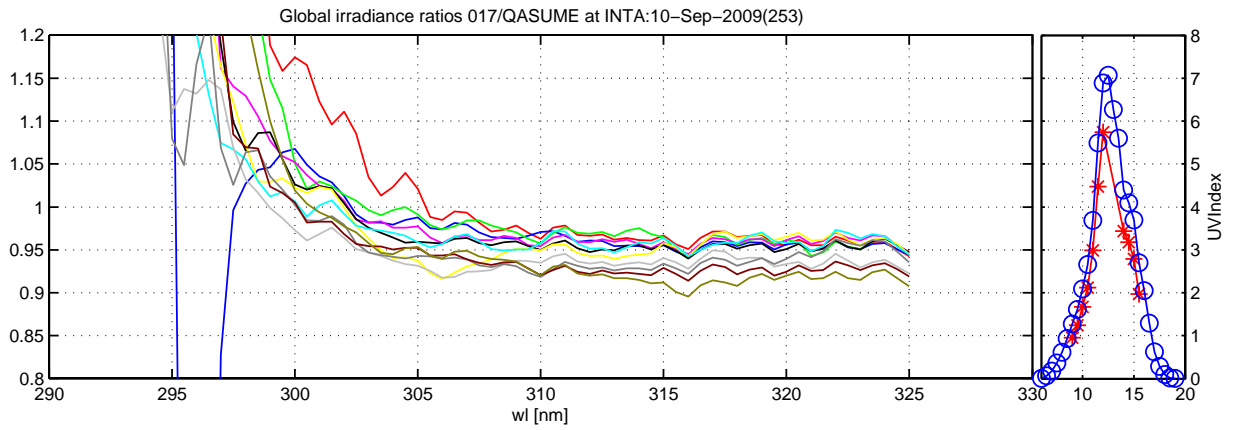

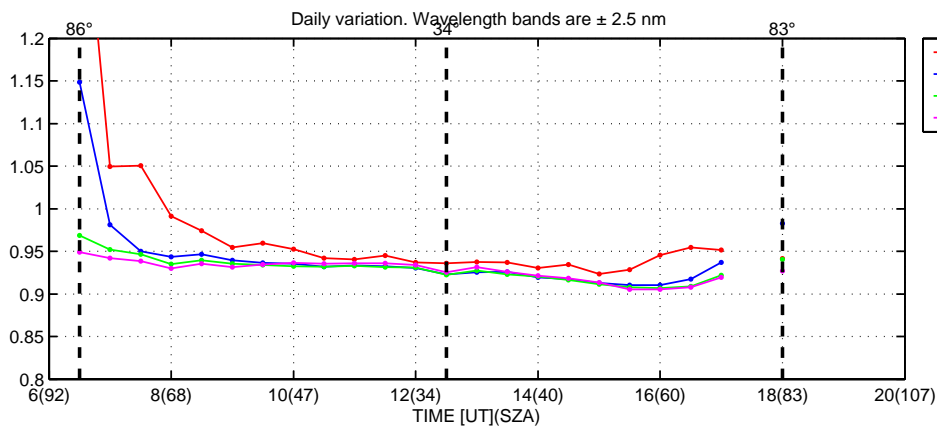
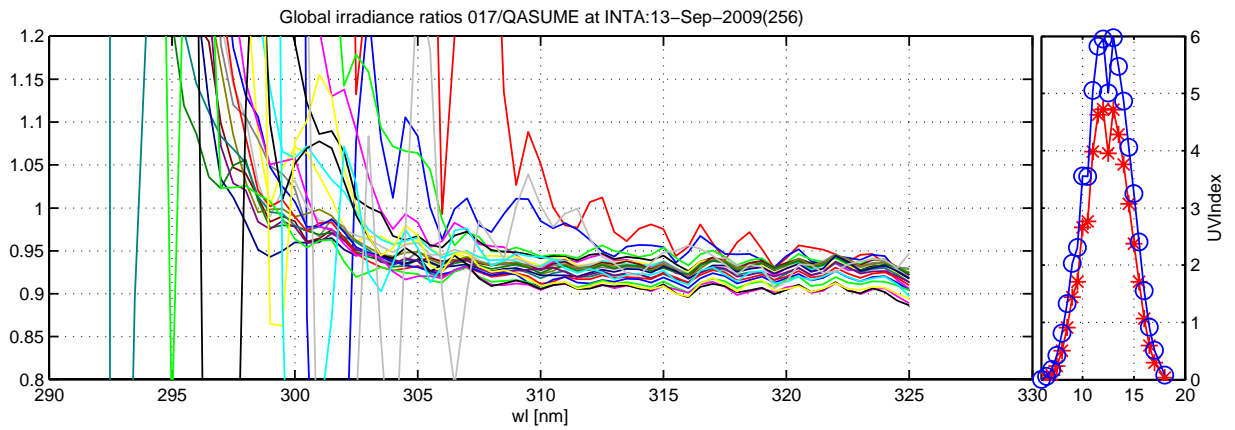
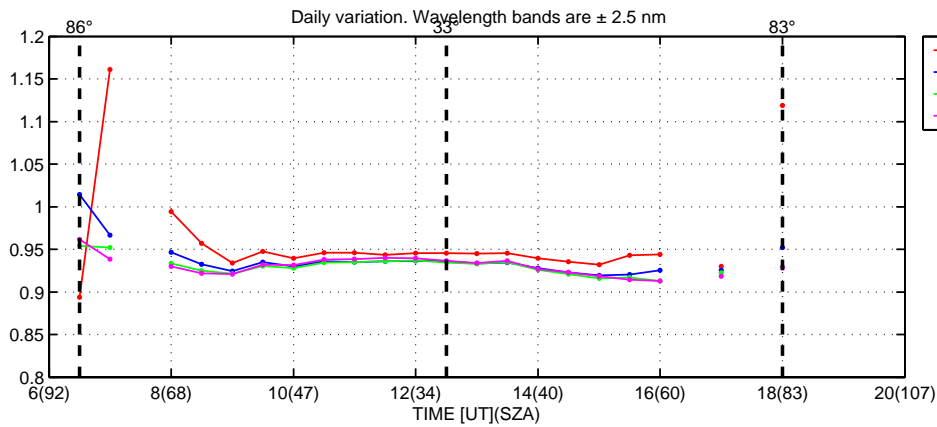
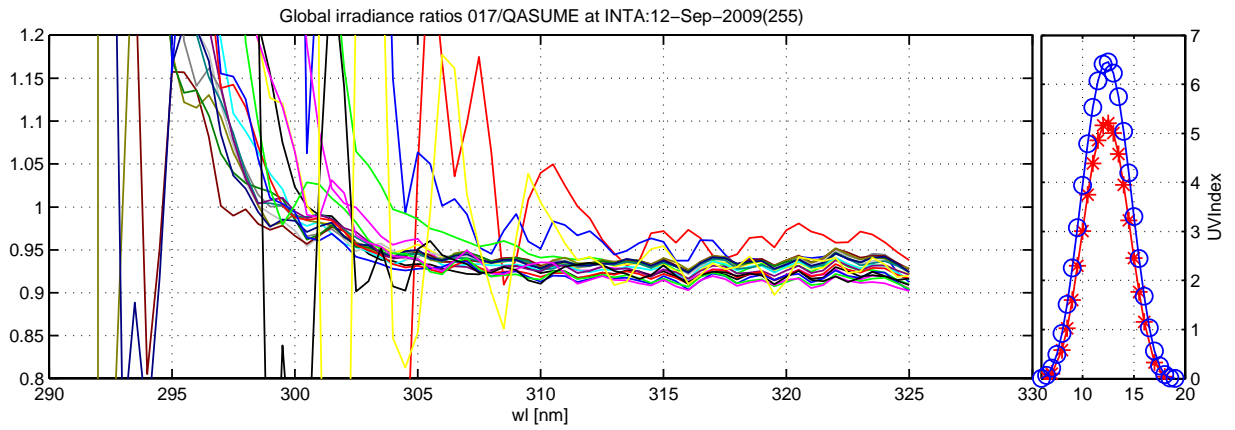

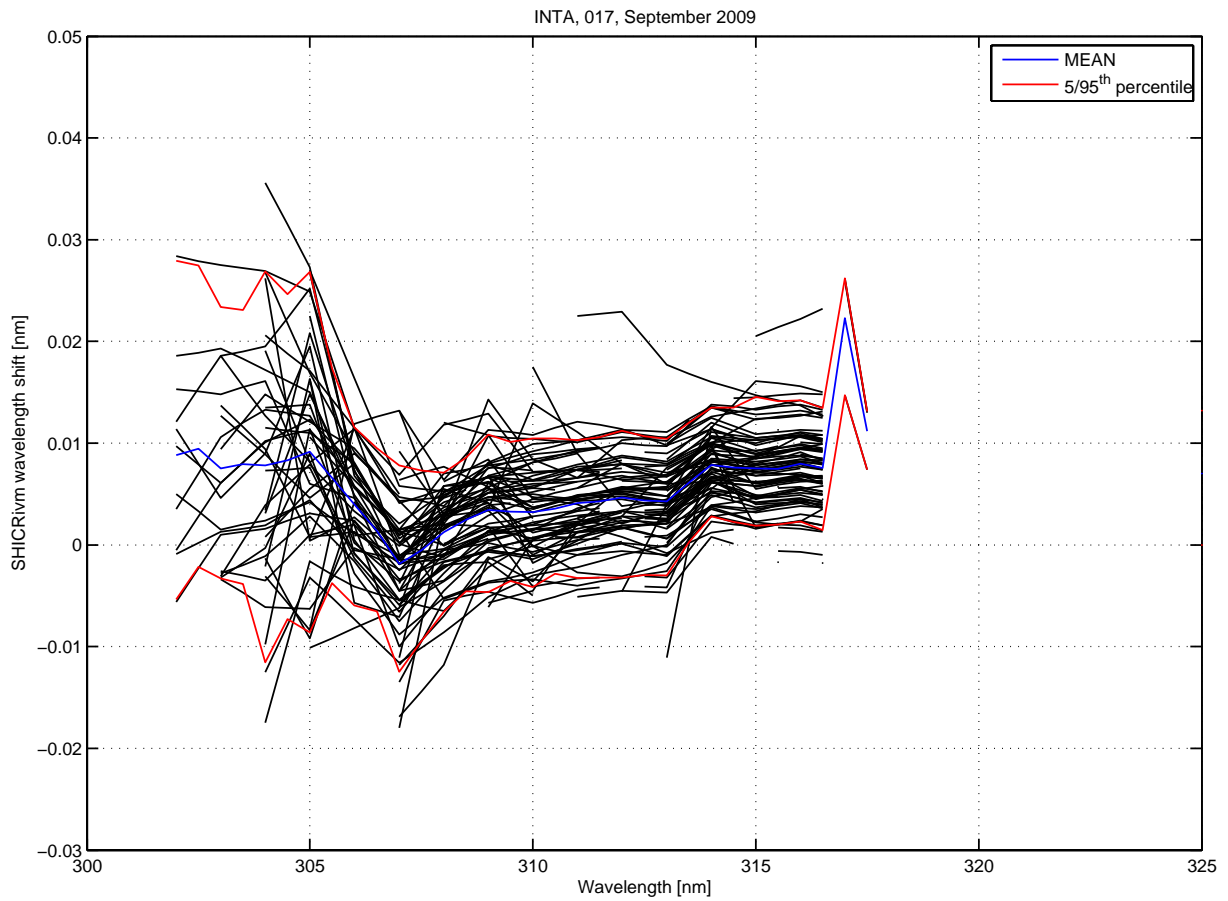
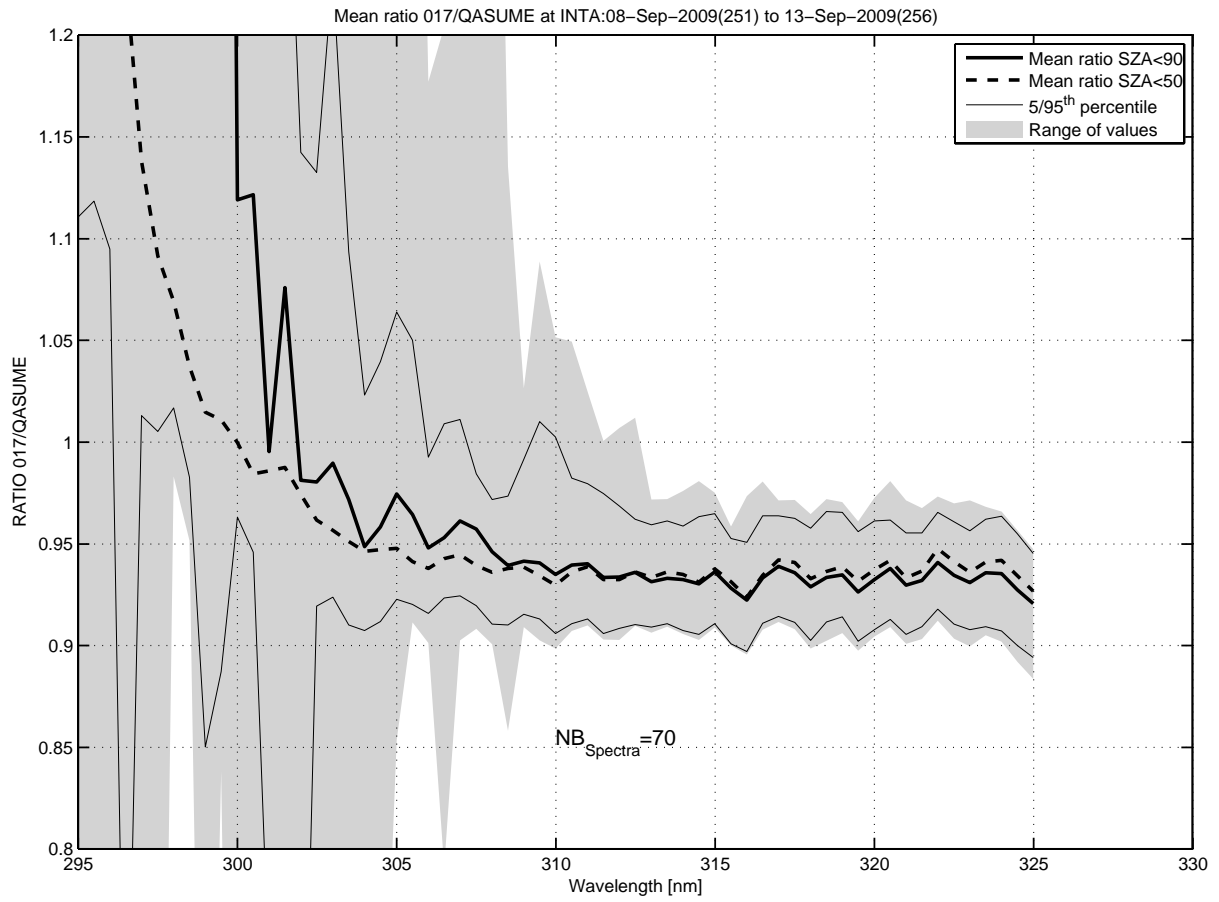

UV Index INTA, September 2009

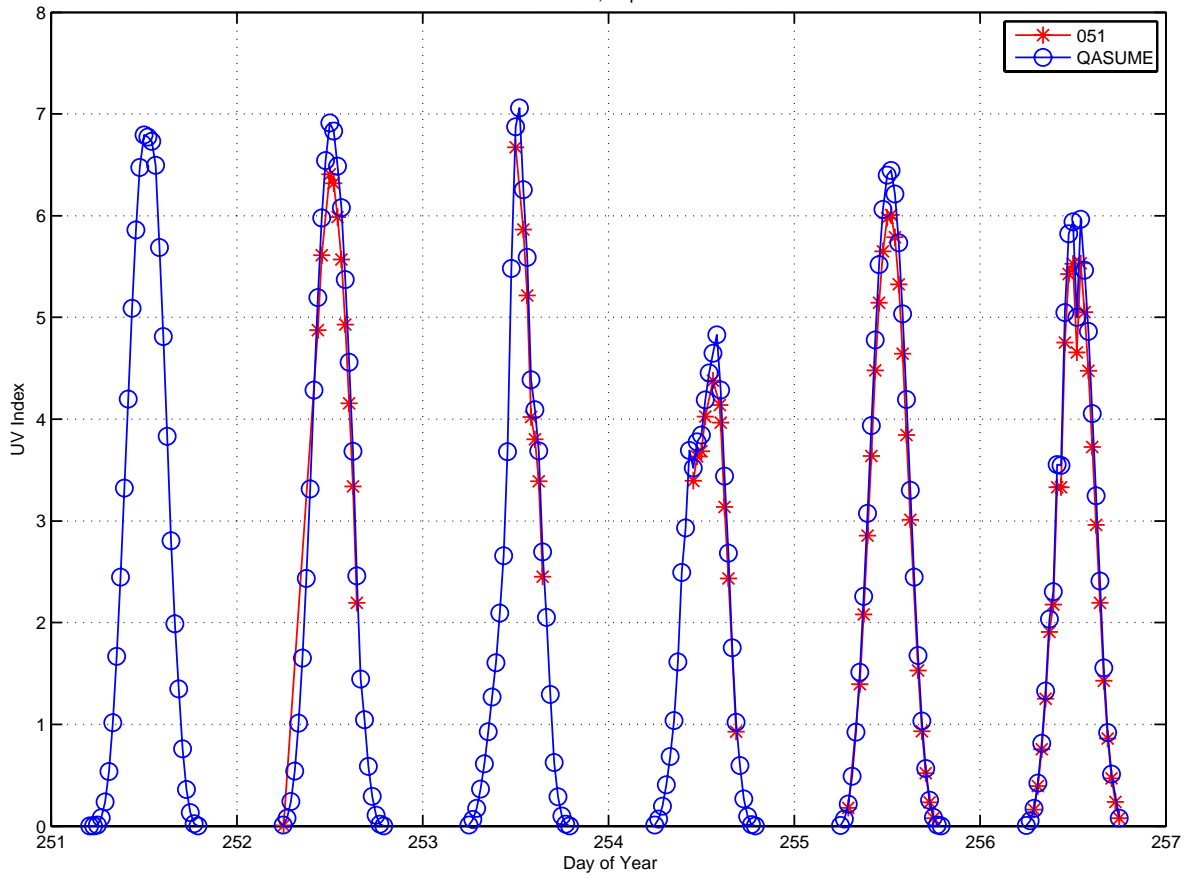

Global irradiance ratios 051/QASUME at INTA:09-Sep-2009(252) to 13-Sep-2009(256)

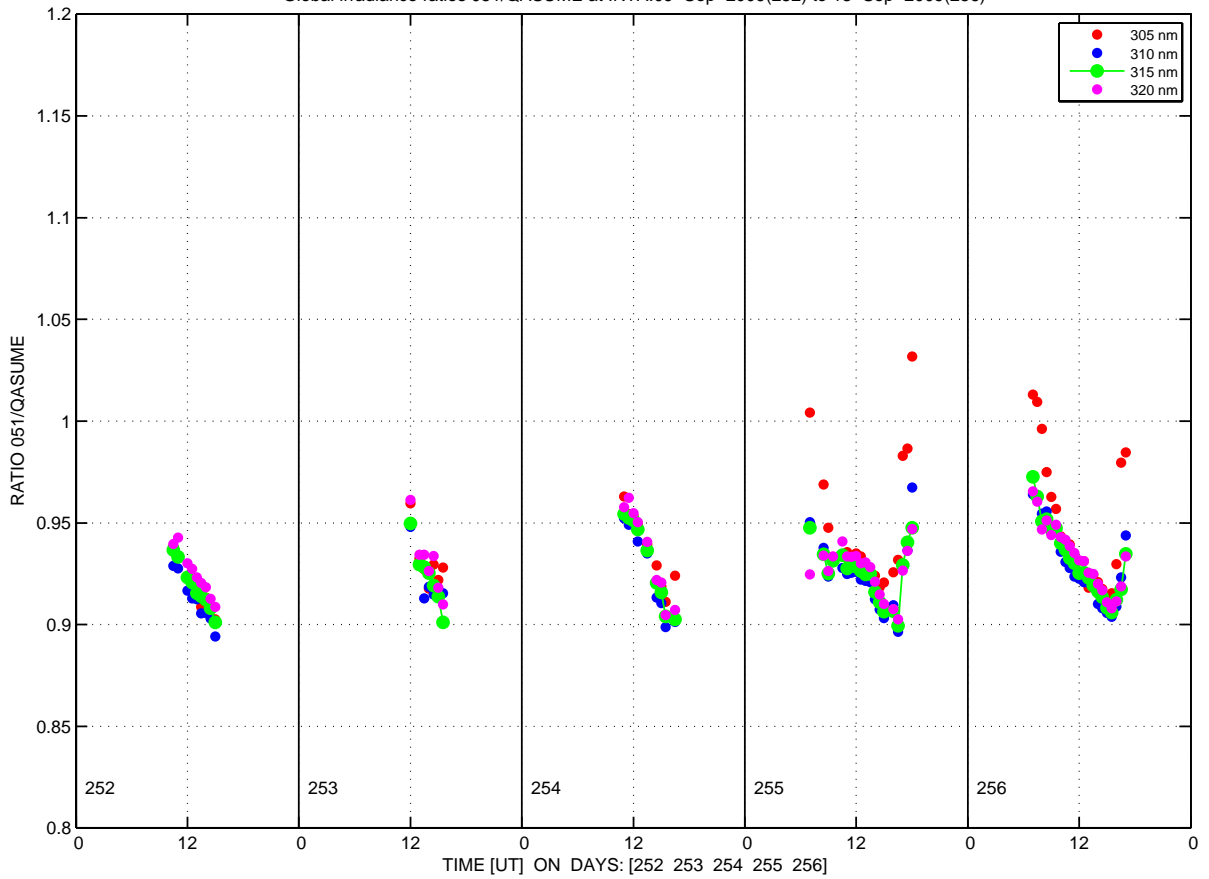

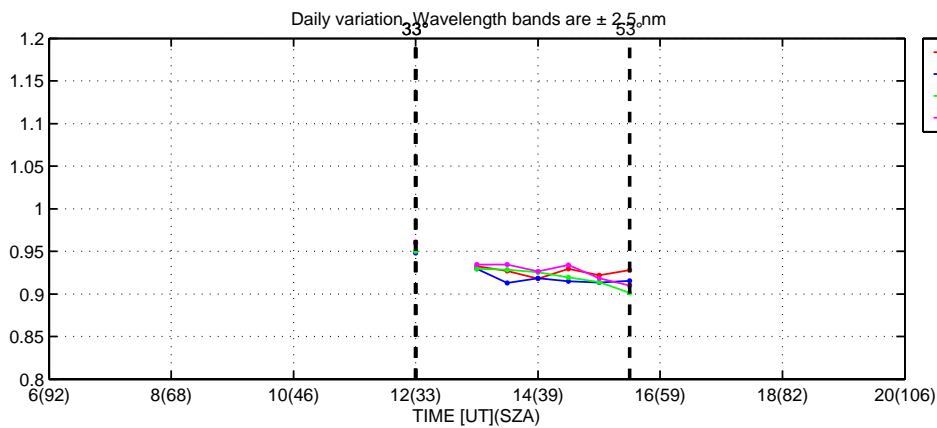
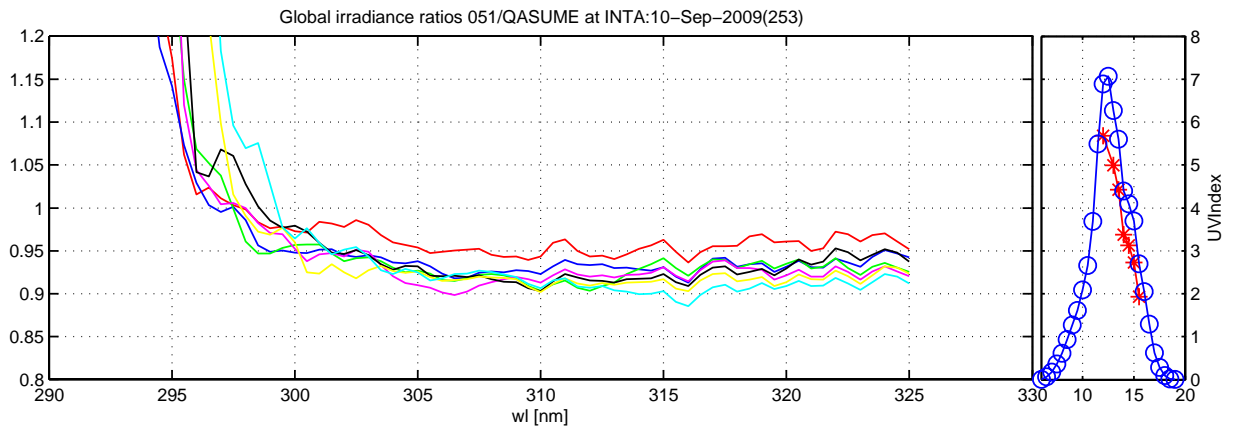
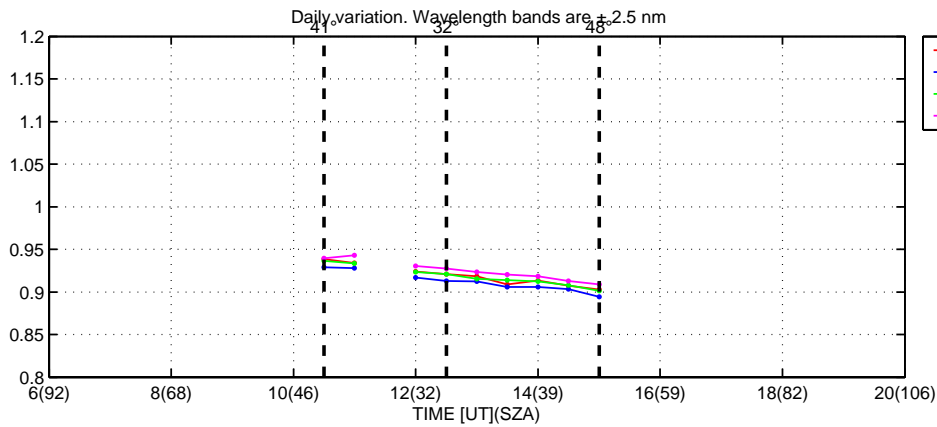
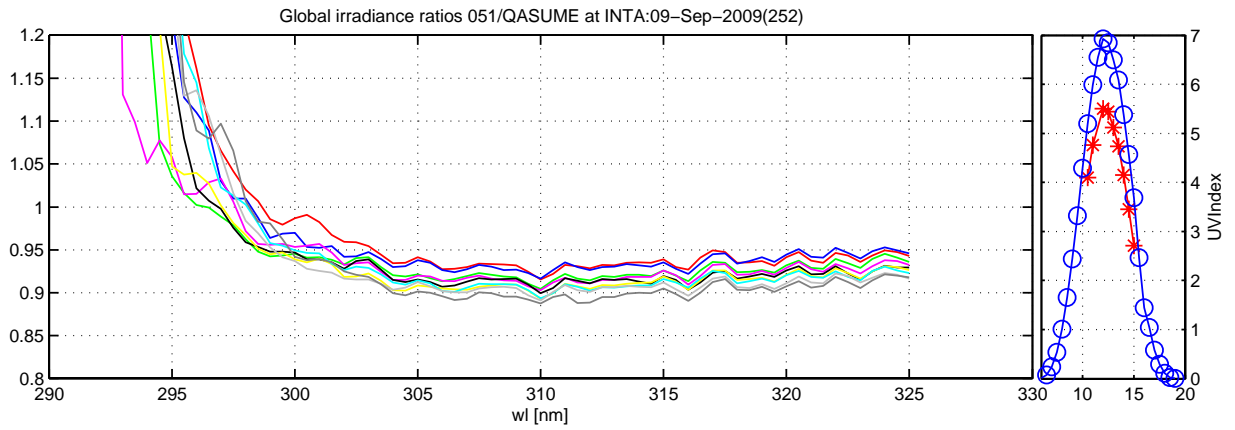

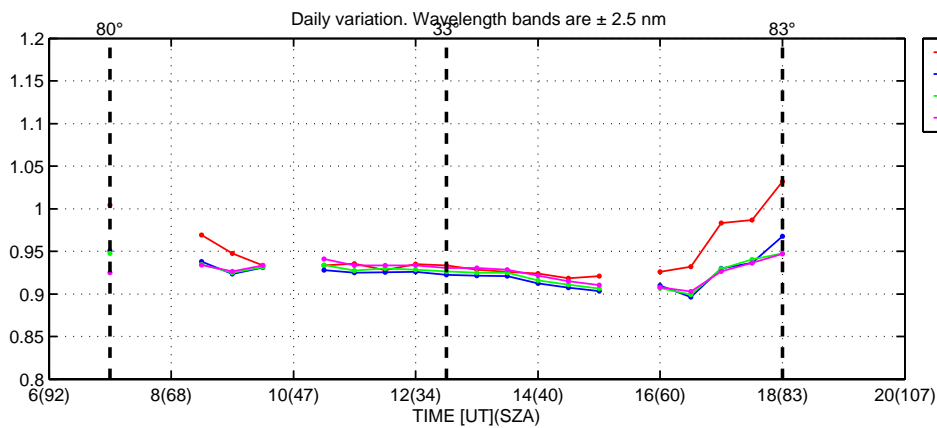
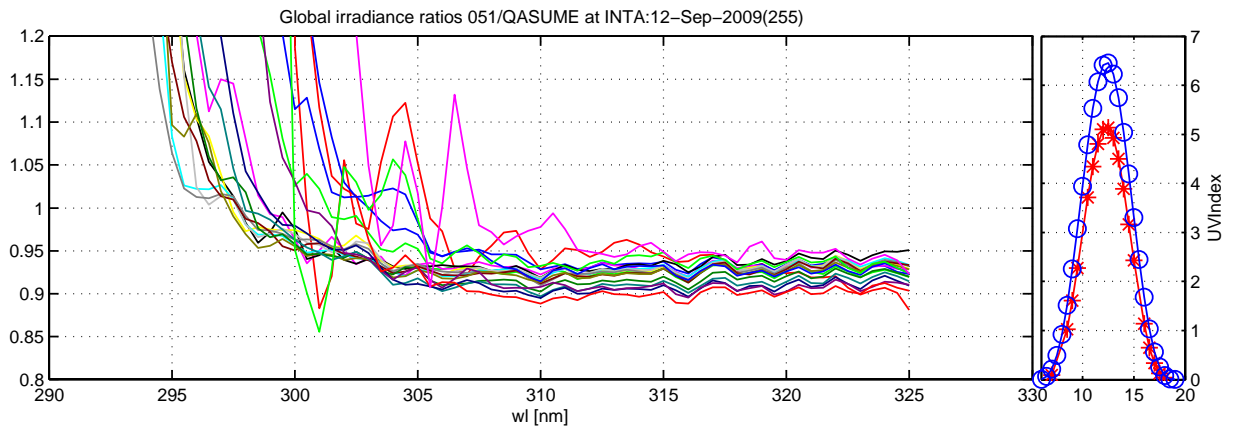
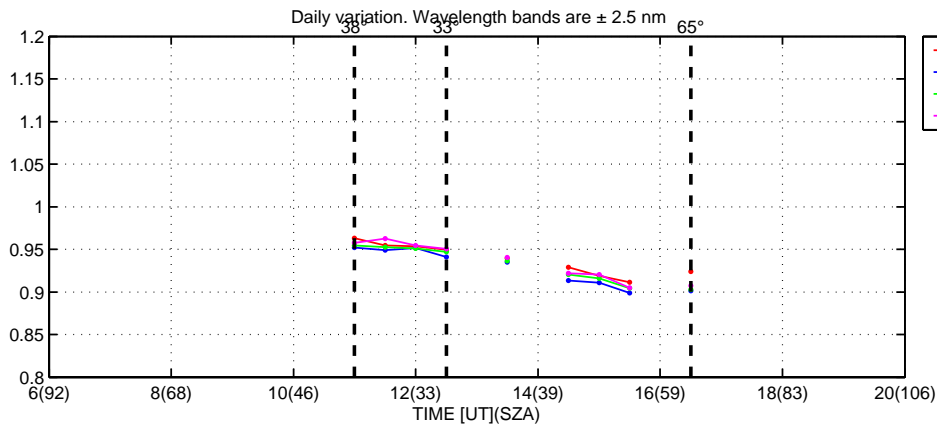
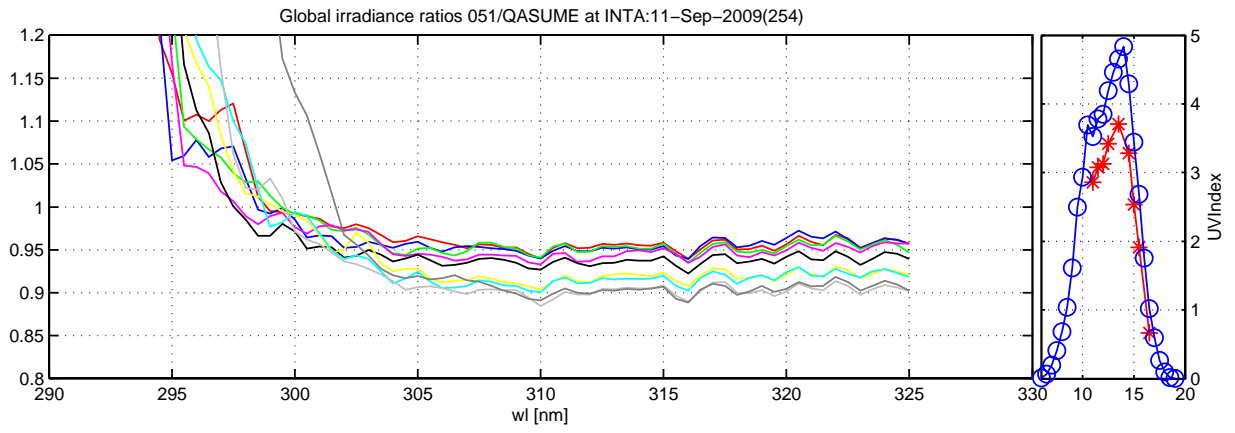

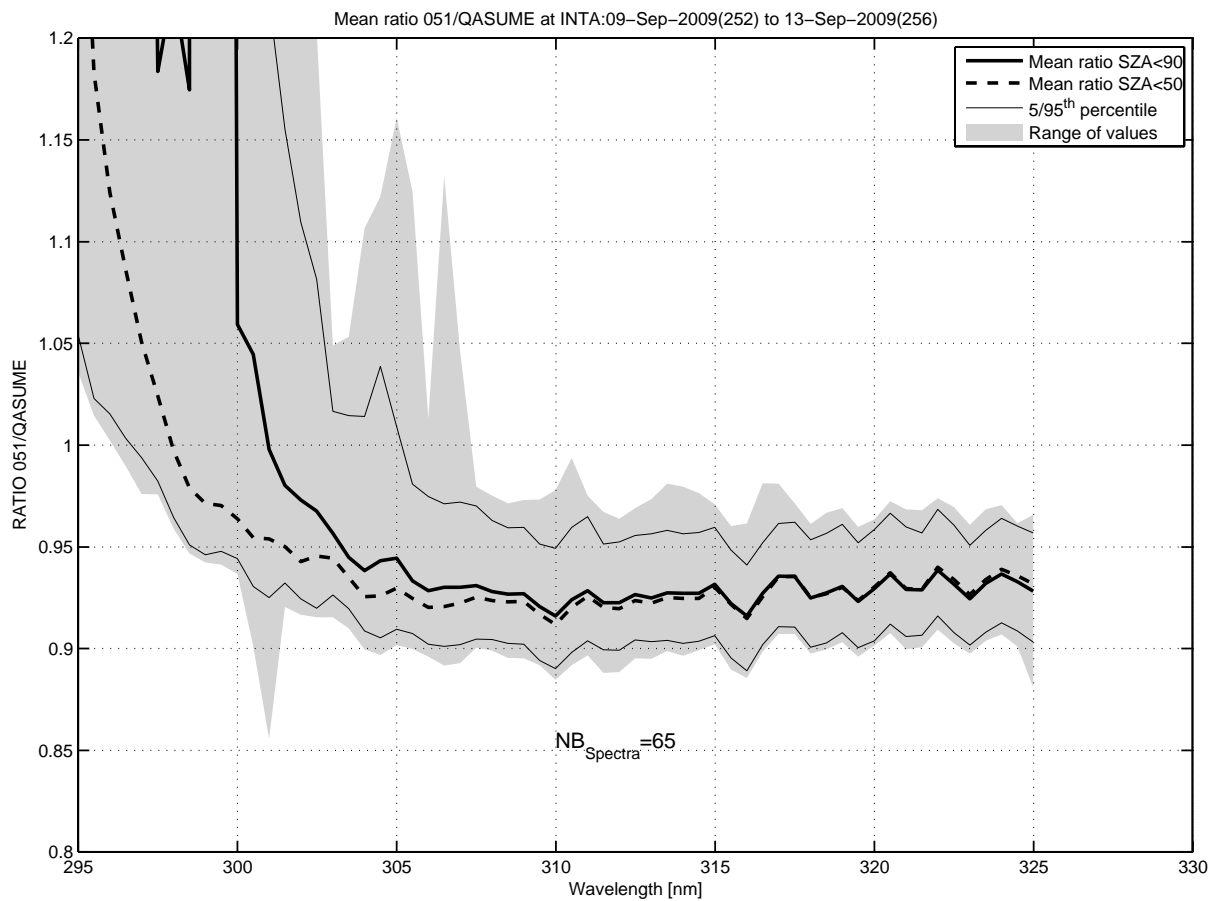
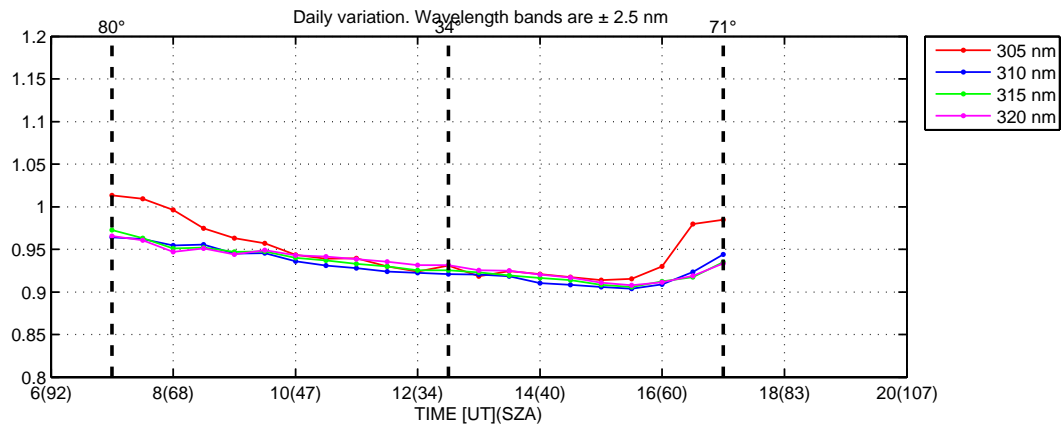
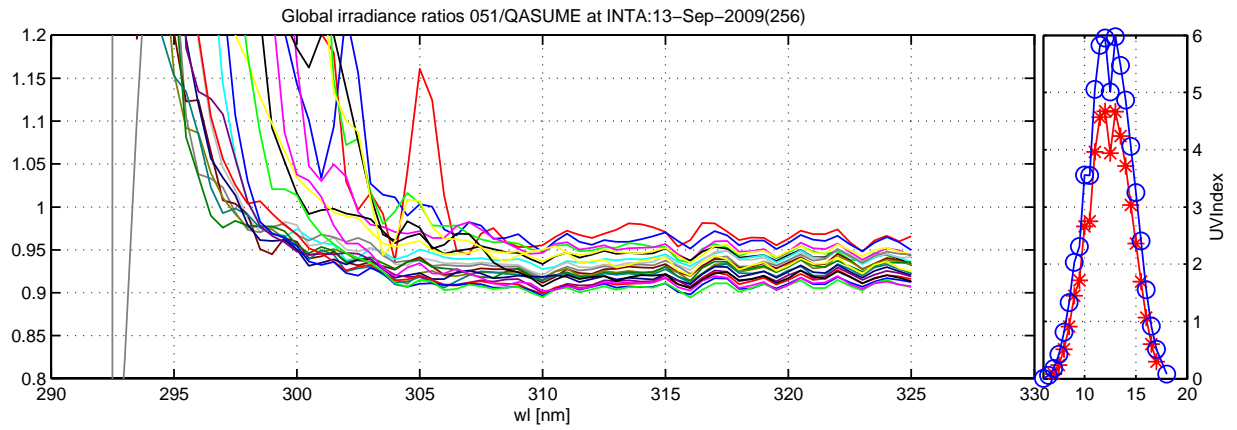

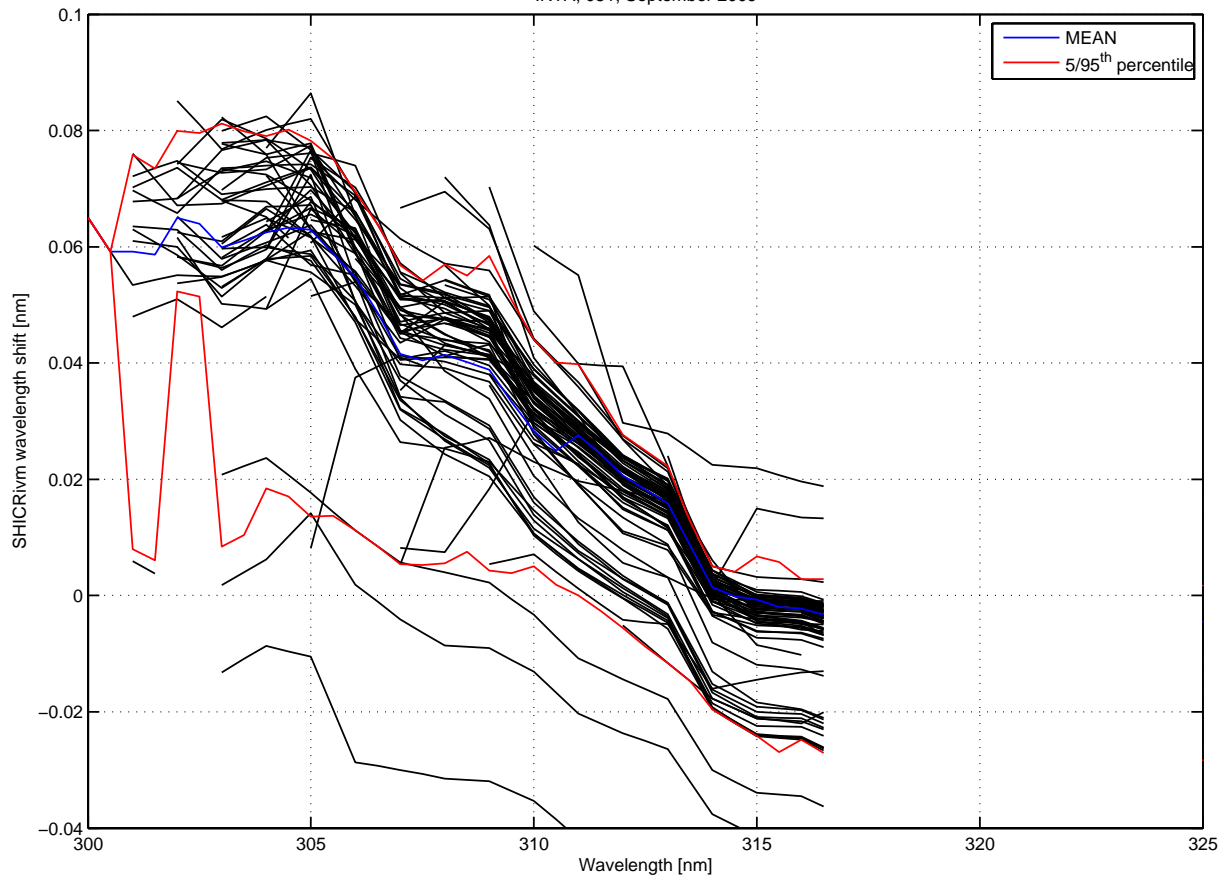



UV Index INTA, September 2009

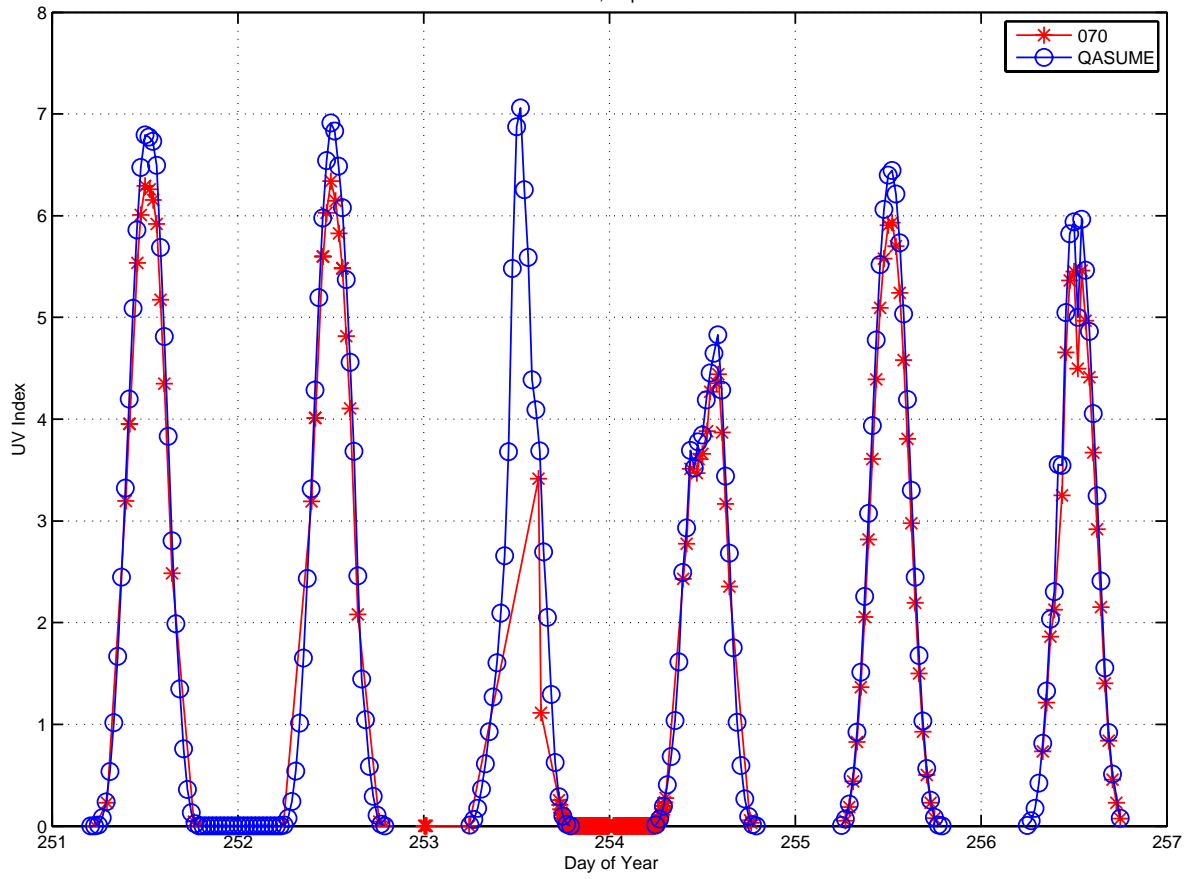

Global irradiance ratios 070/QASUME at INTA:08-Sep-2009(251) to 13-Sep-2009(256)

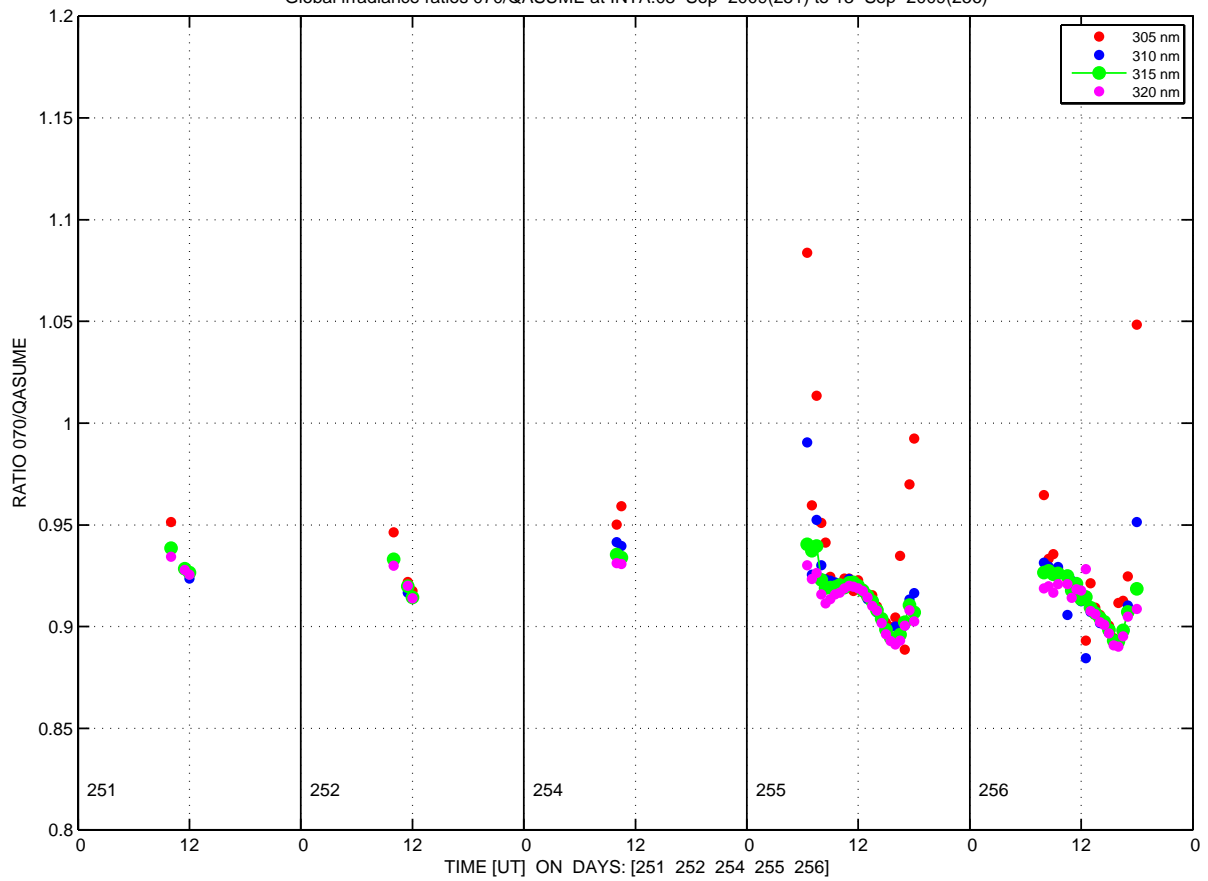

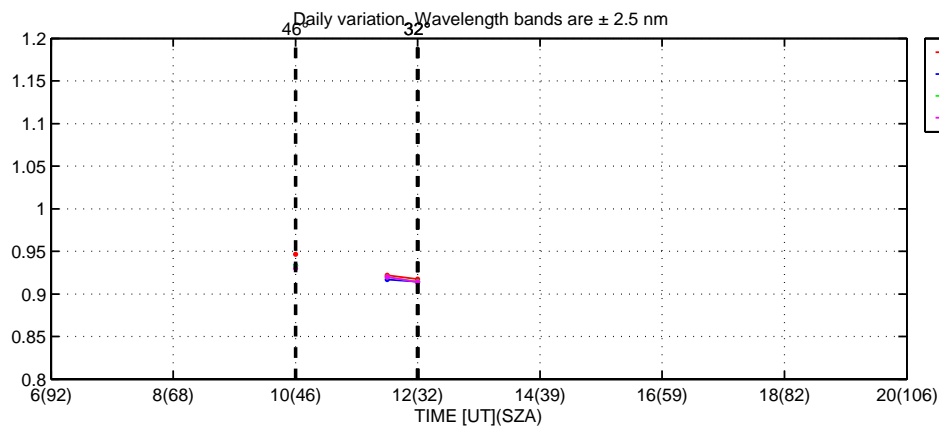
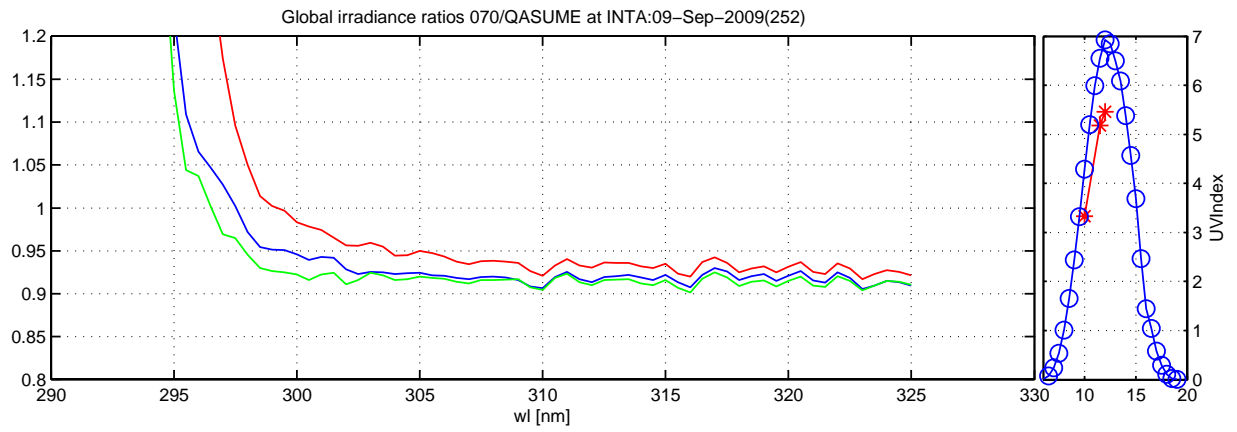
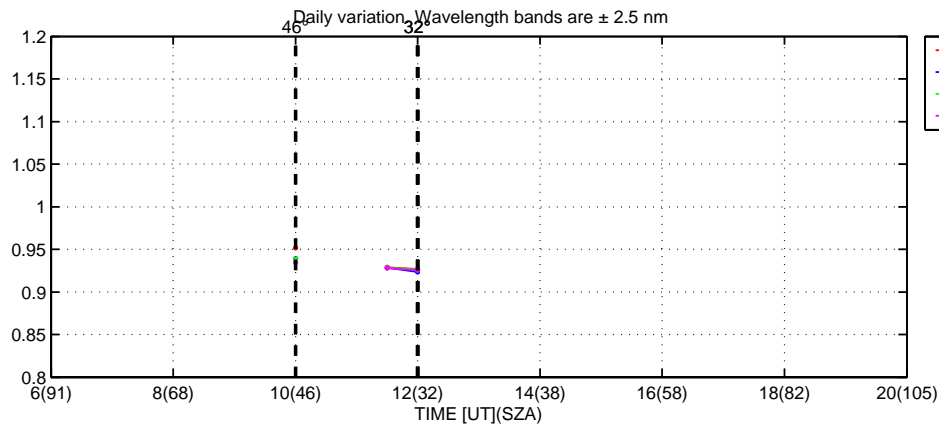
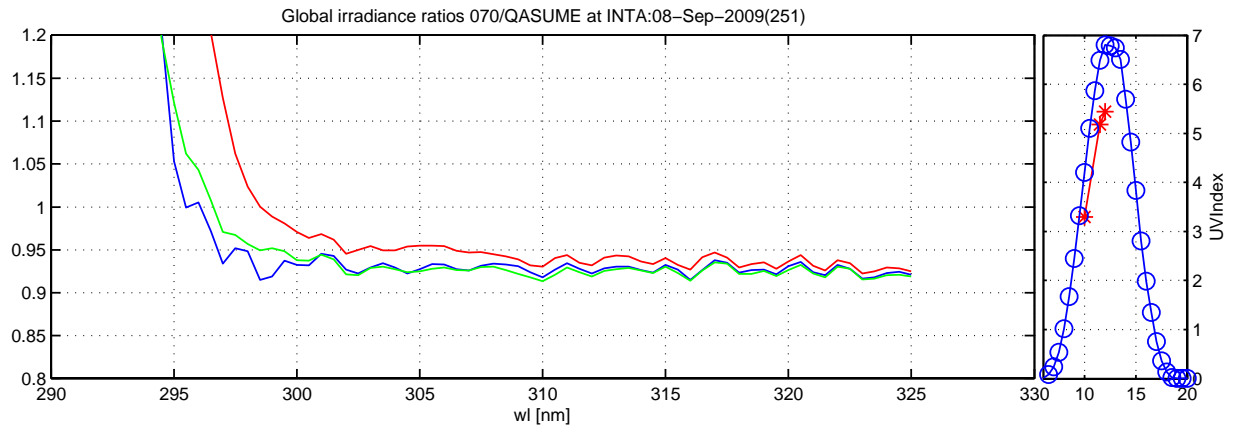

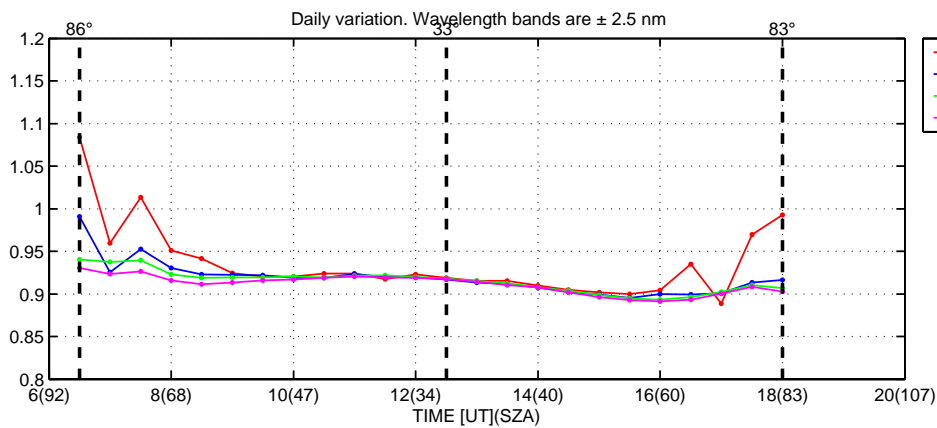
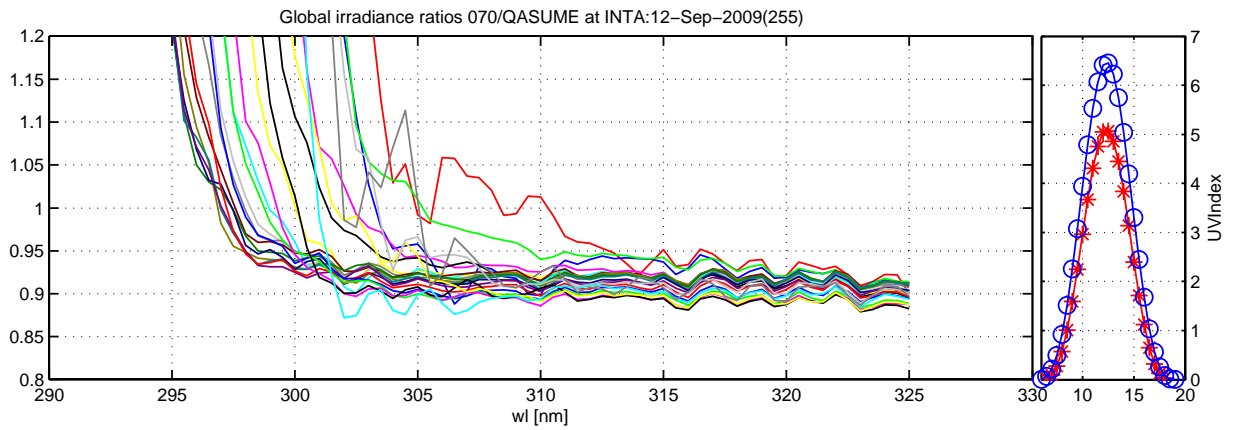
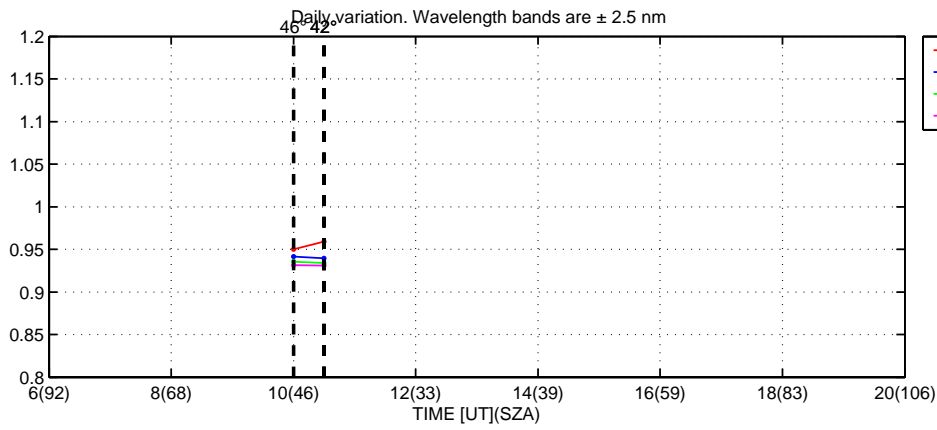
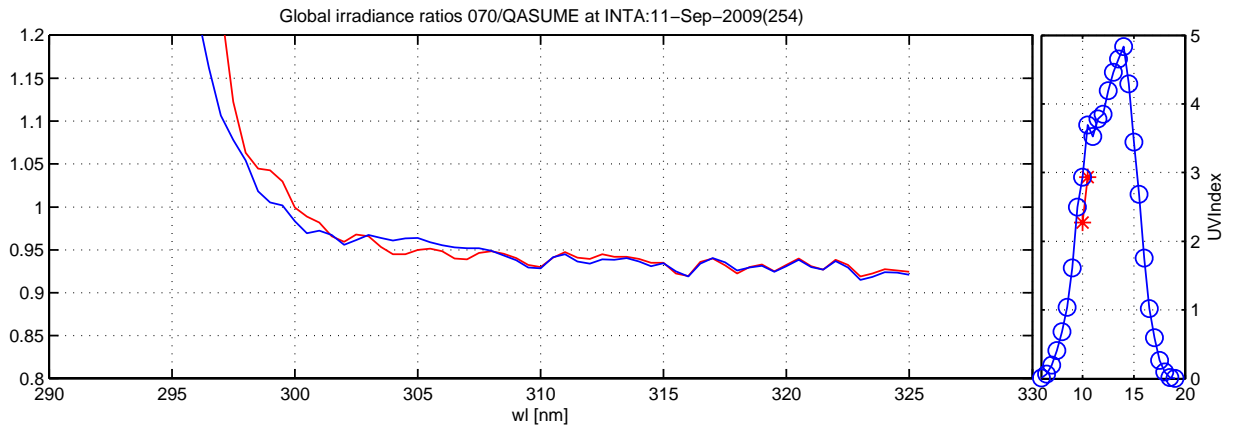

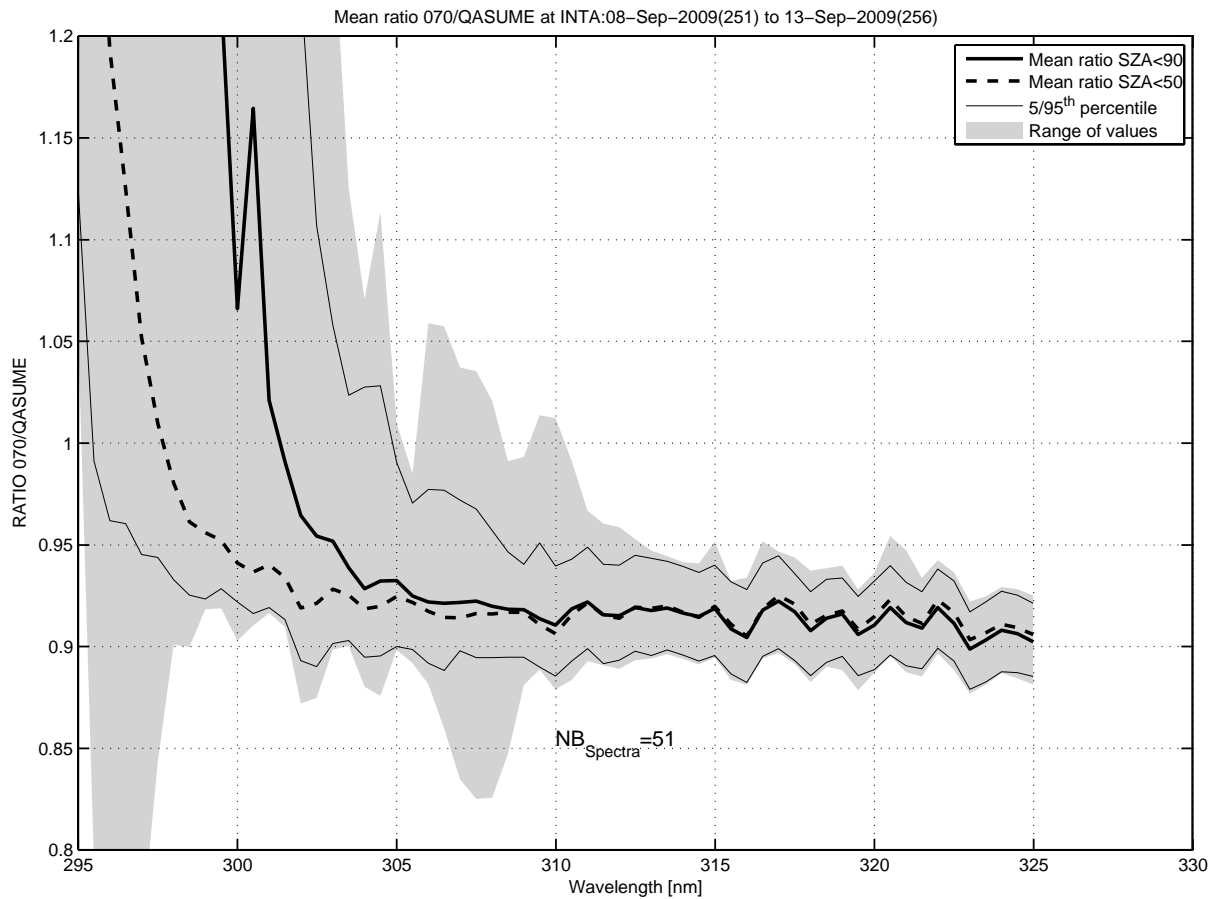
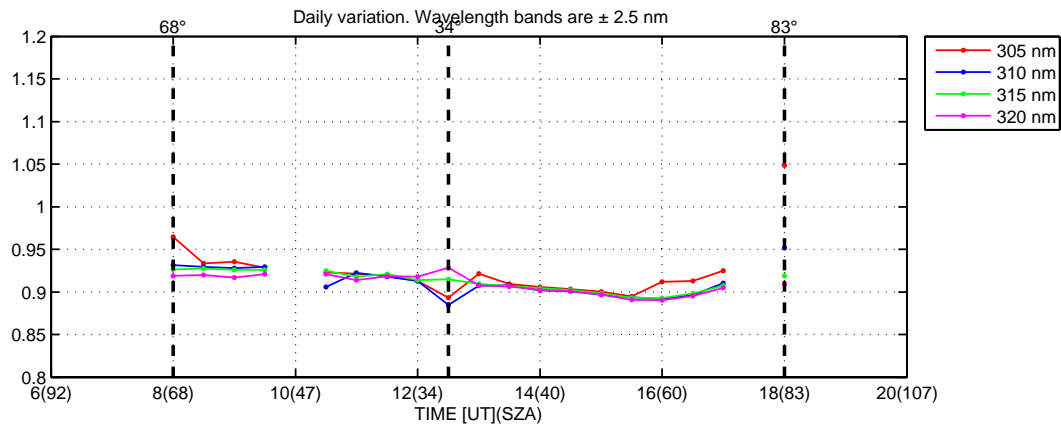
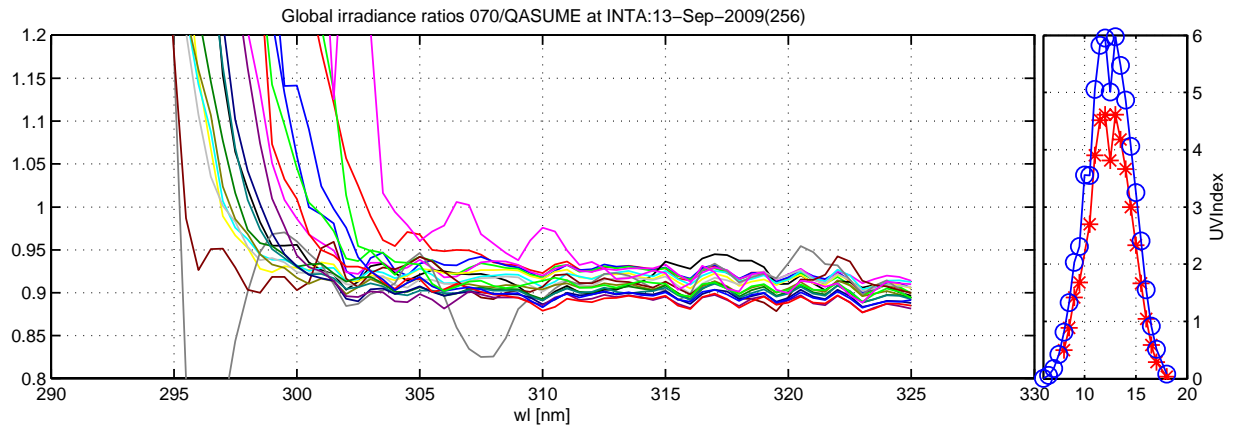

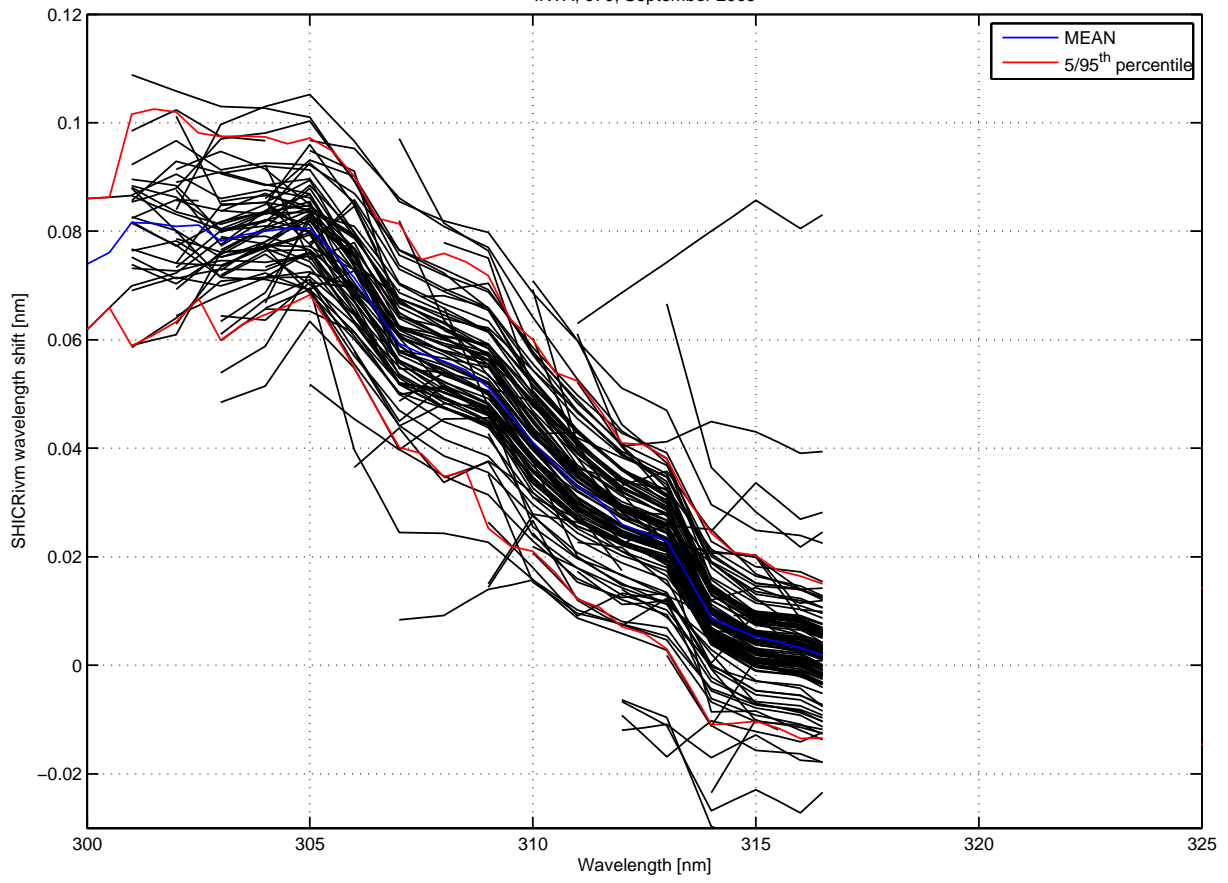

UV Index INTA, September 2009

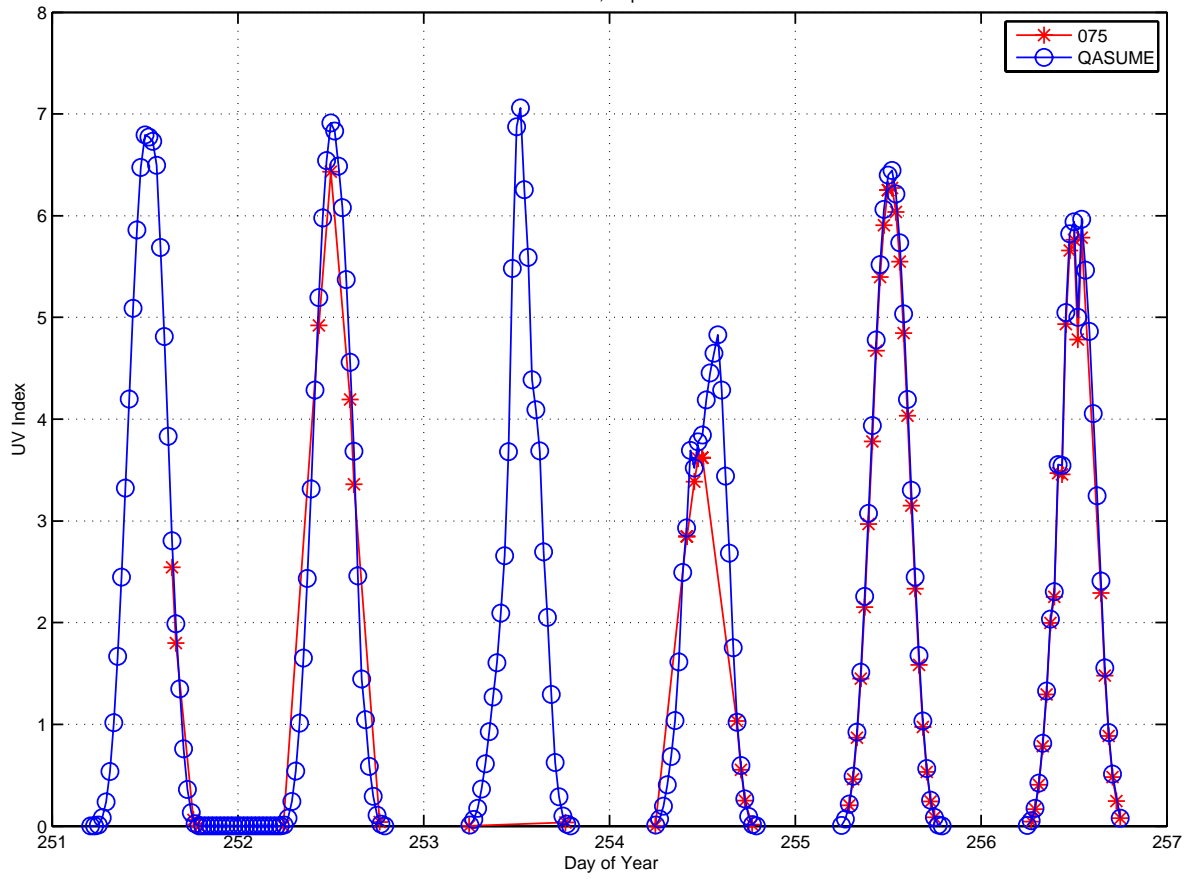

Global irradiance ratios 075/QASUME at INTA:08-Sep-2009(251) to 13-Sep-2009(256)

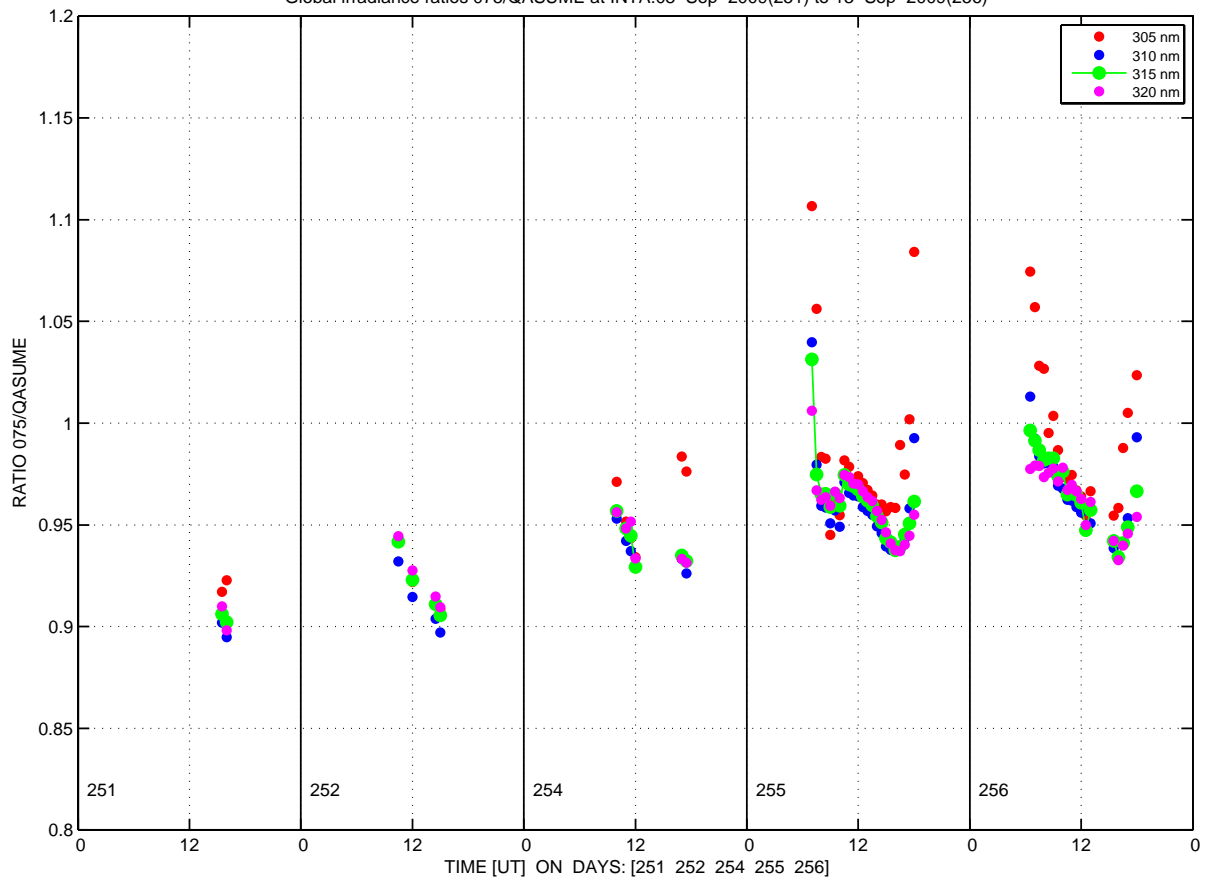

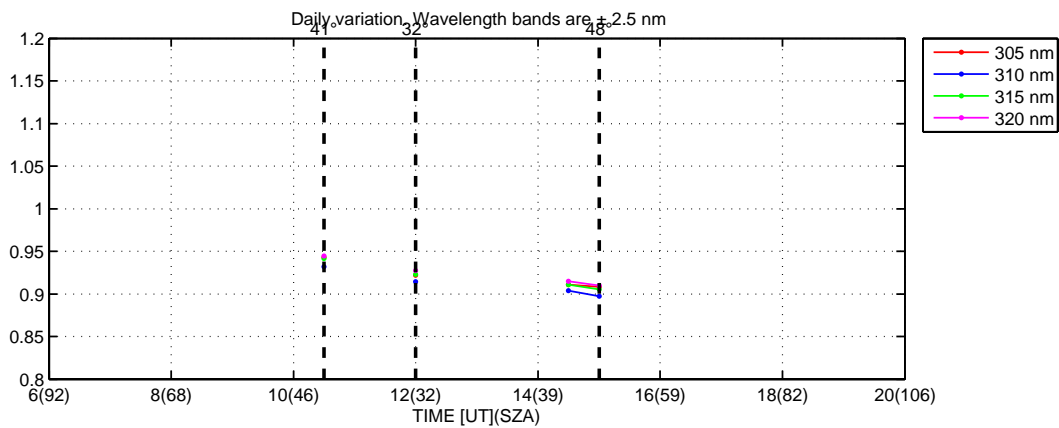
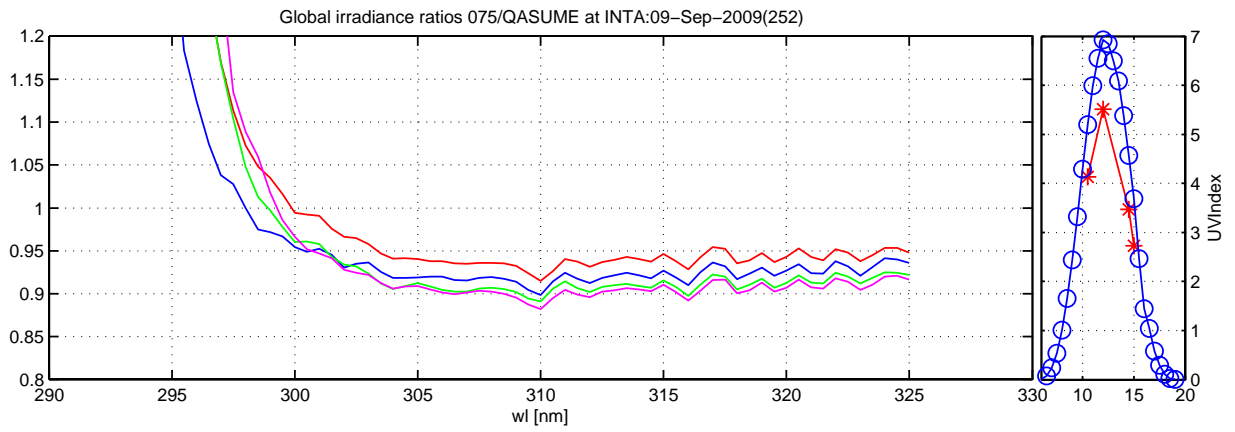
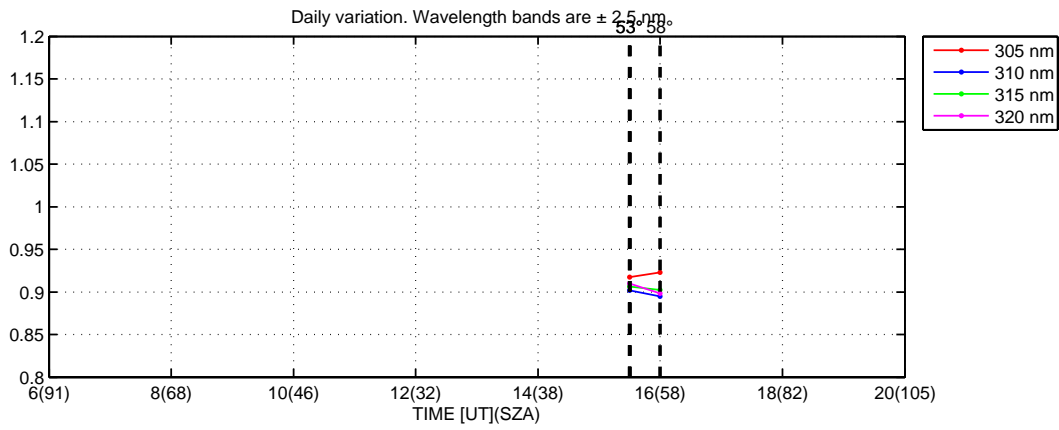
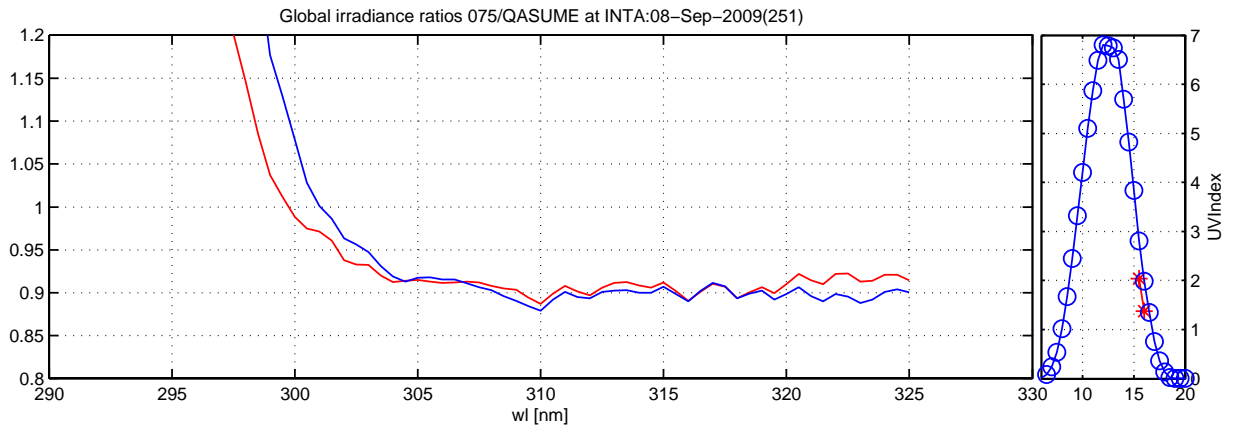

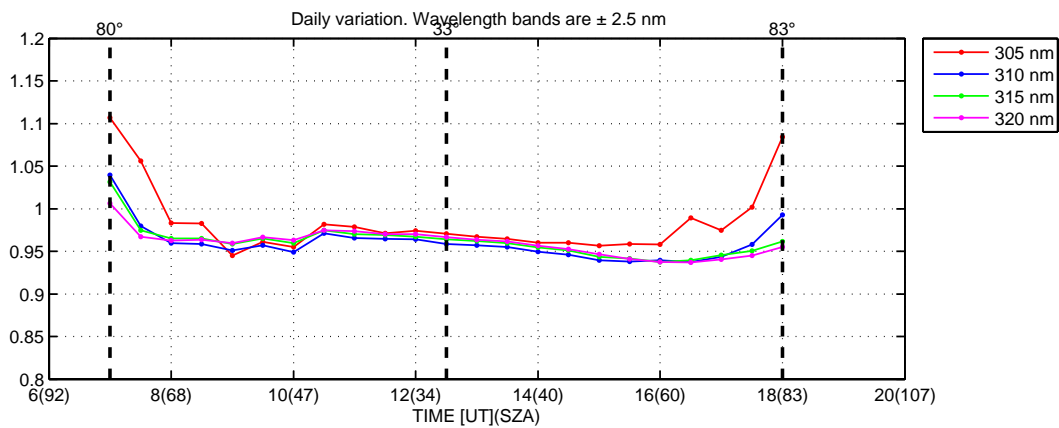
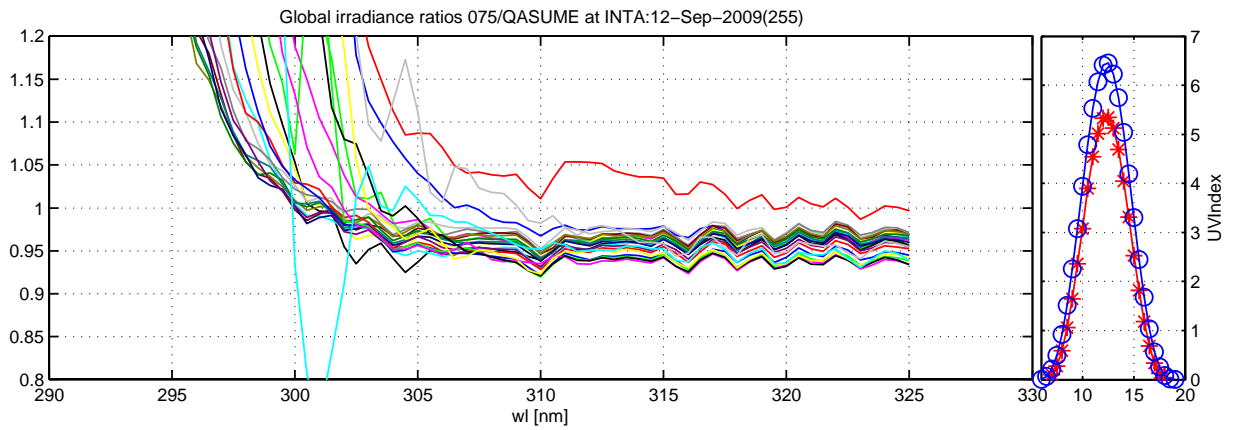
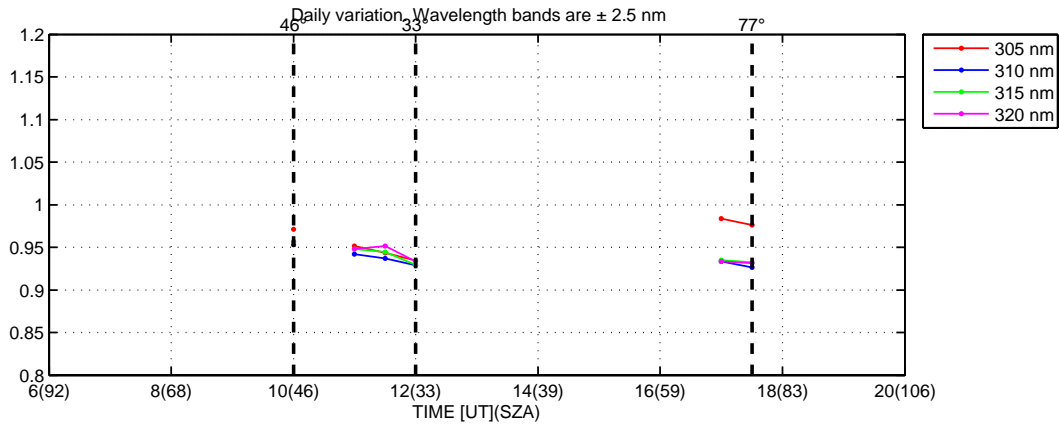
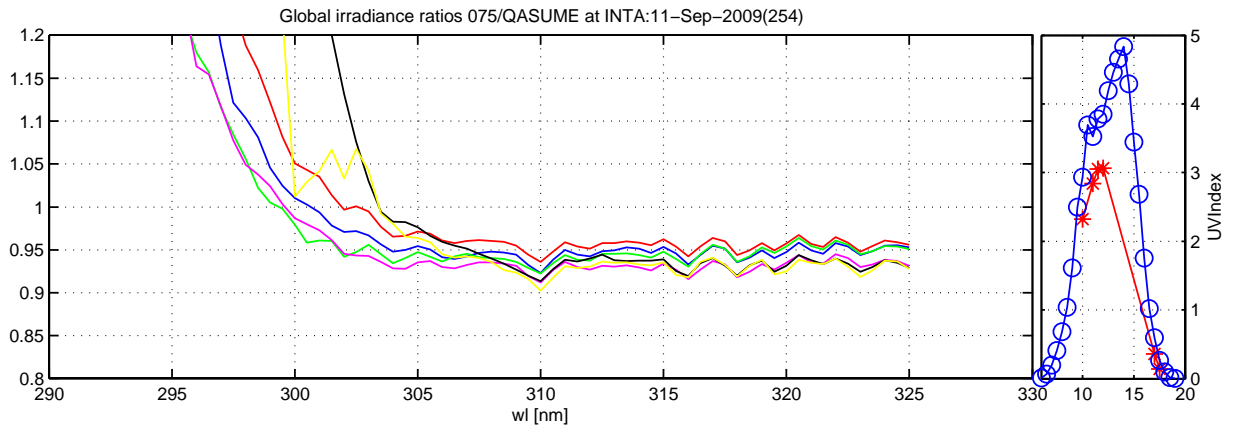



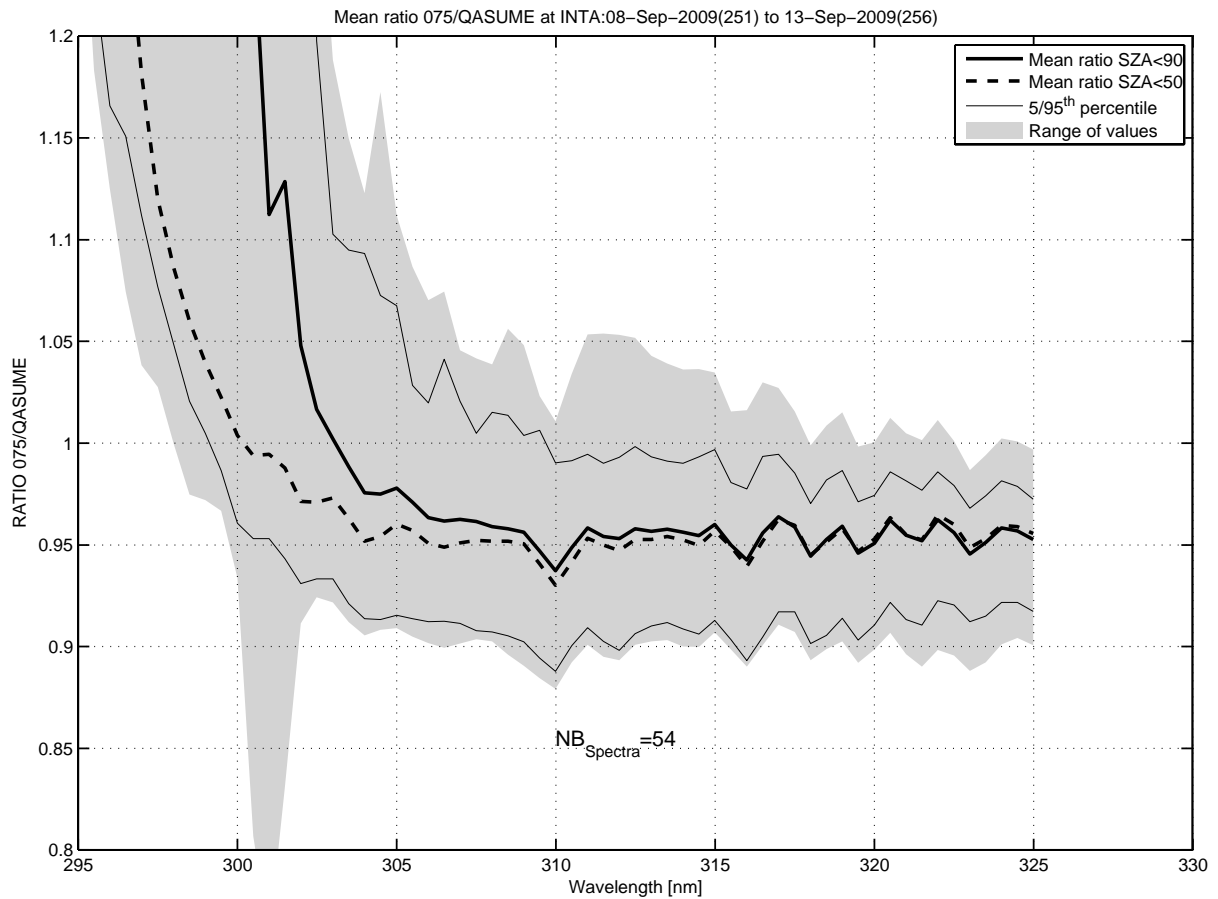
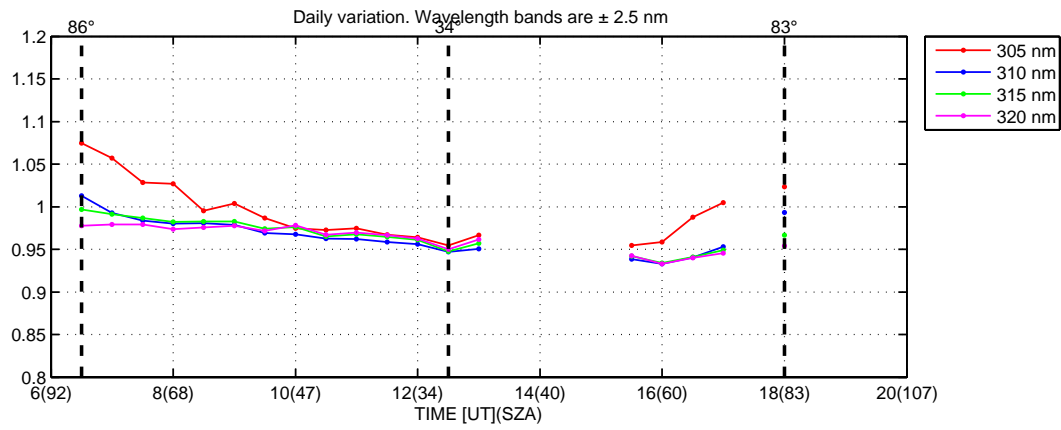
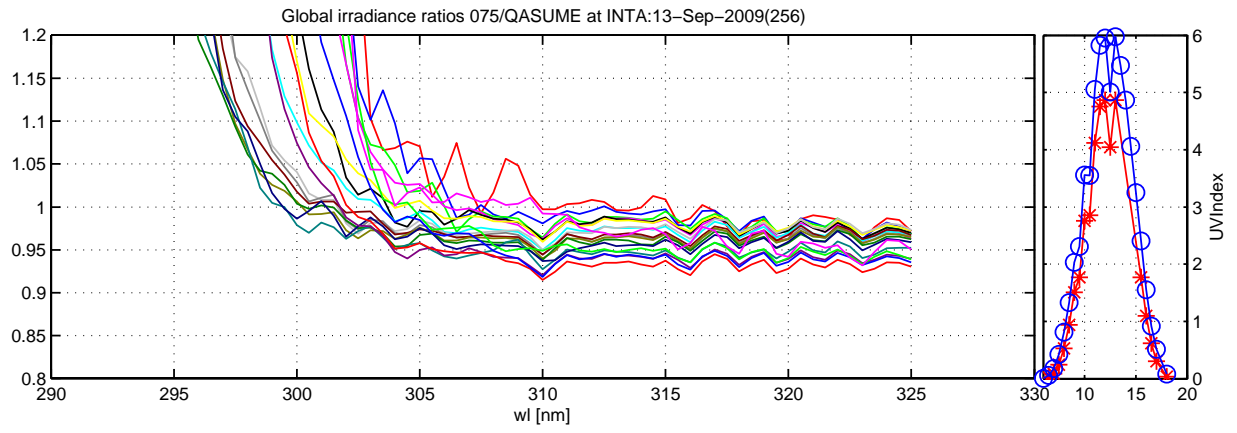

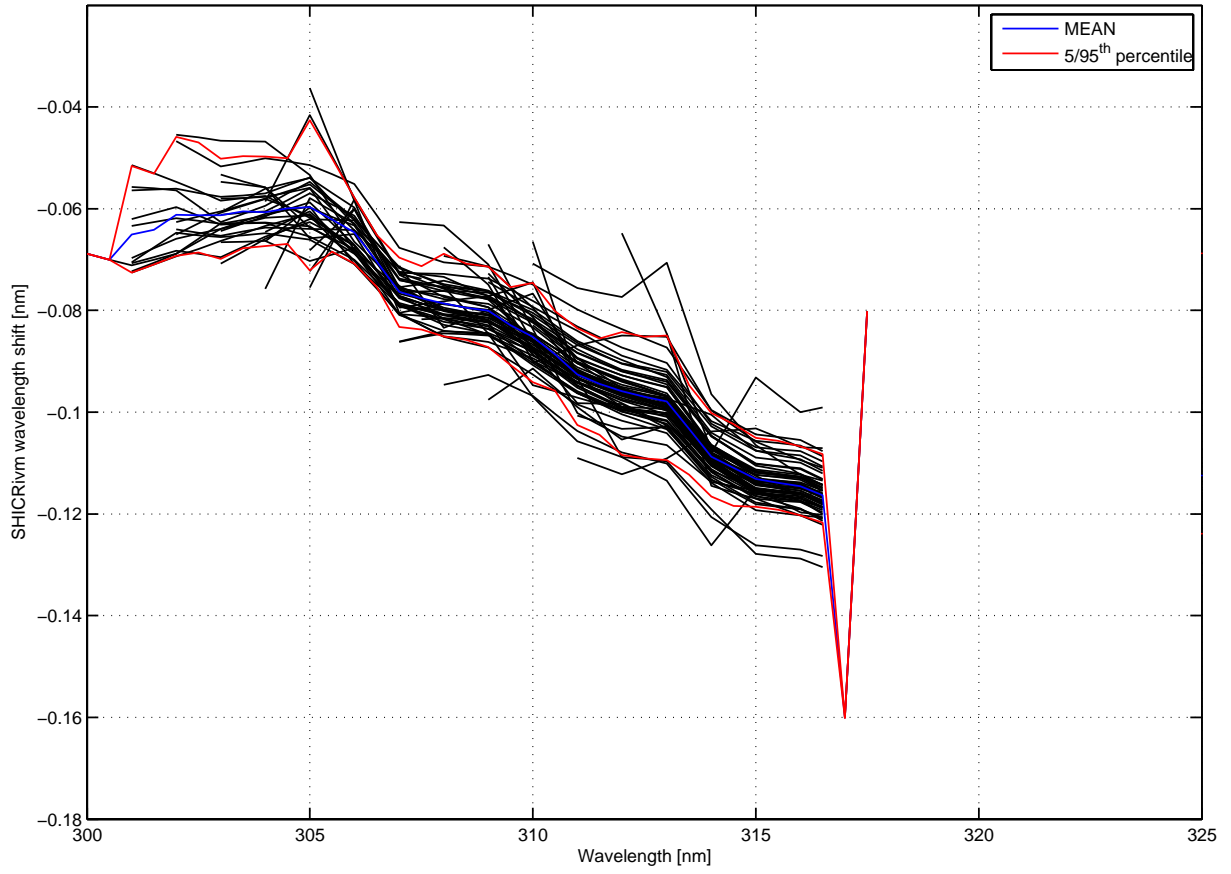

UV Index INTA, September 2009

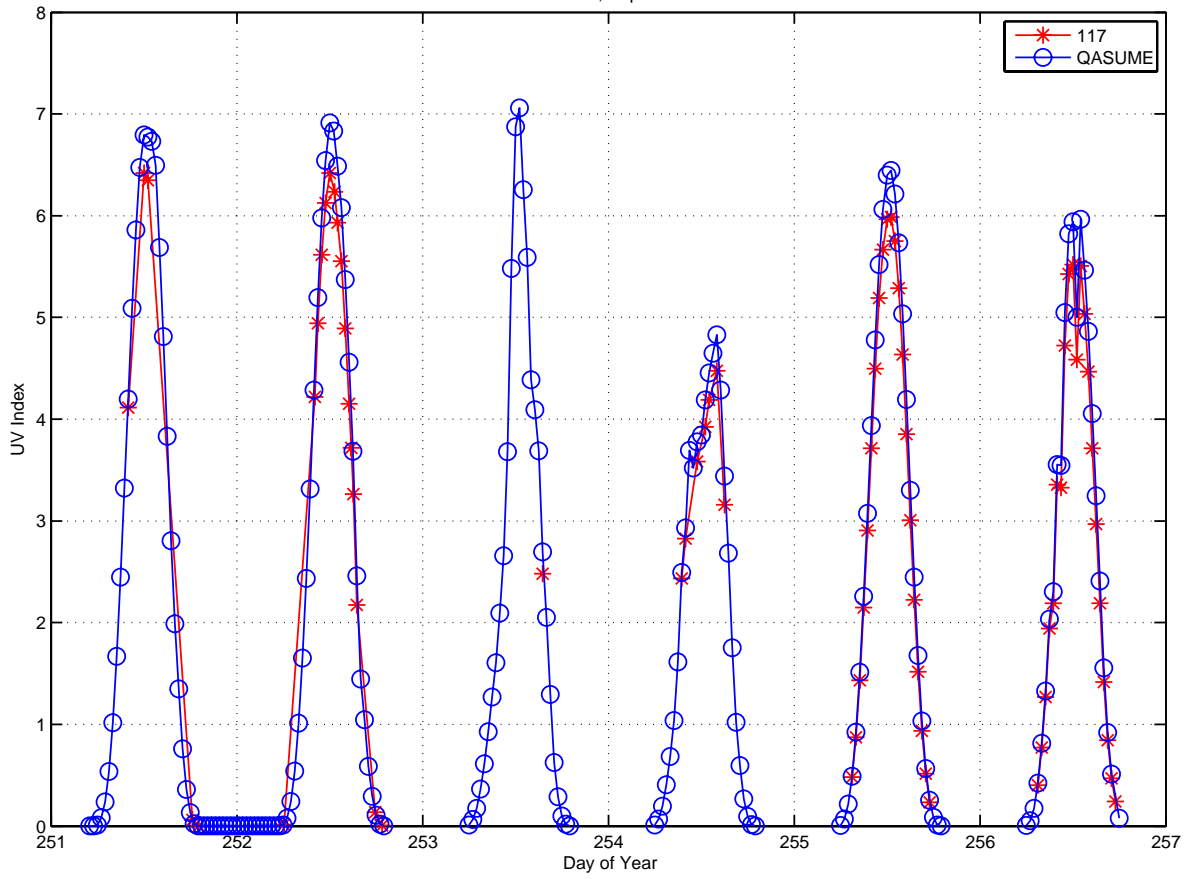

Global irradiance ratios 117/QASUME at INTA:08-Sep-2009(251) to 13-Sep-2009(256)

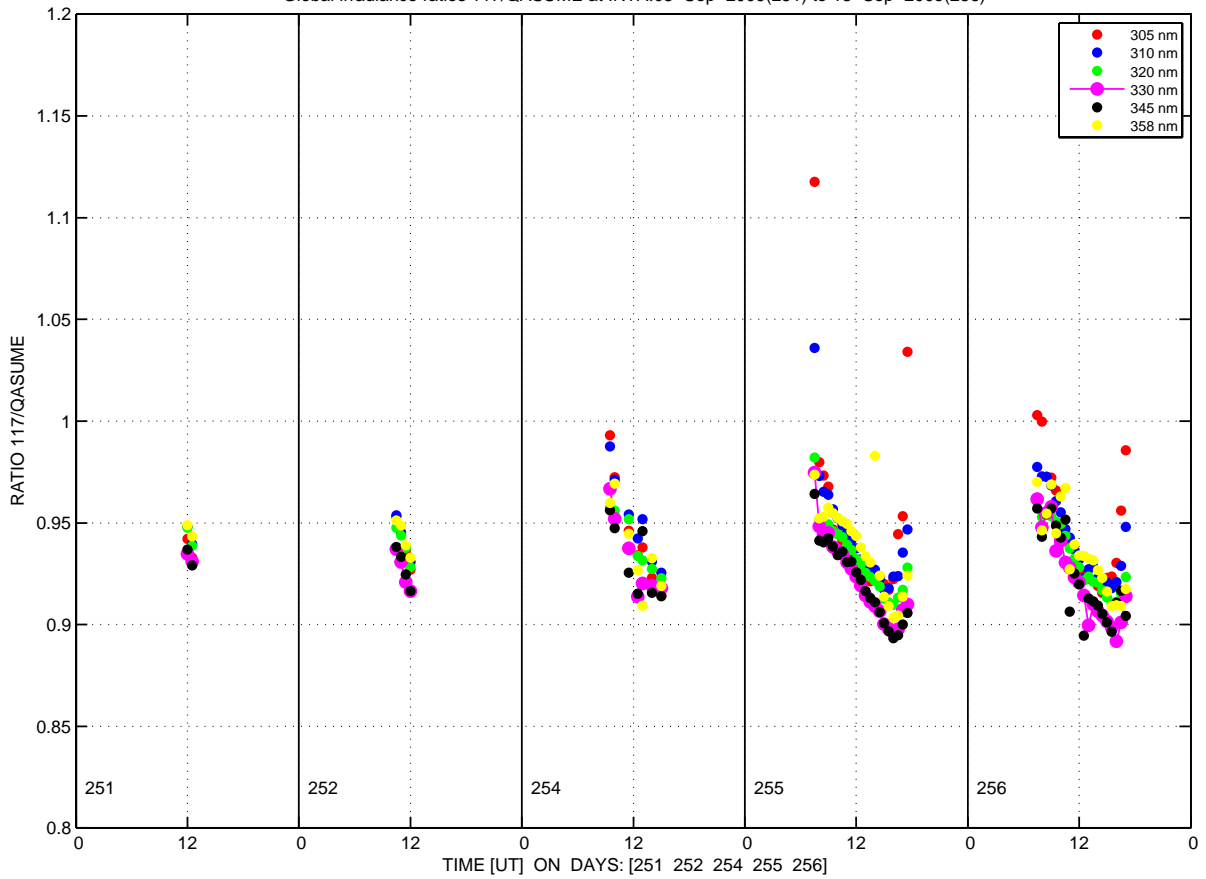

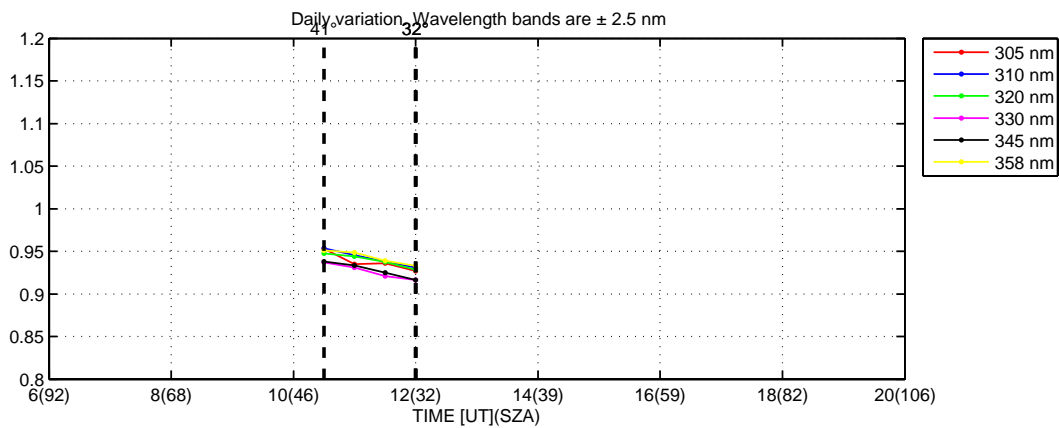
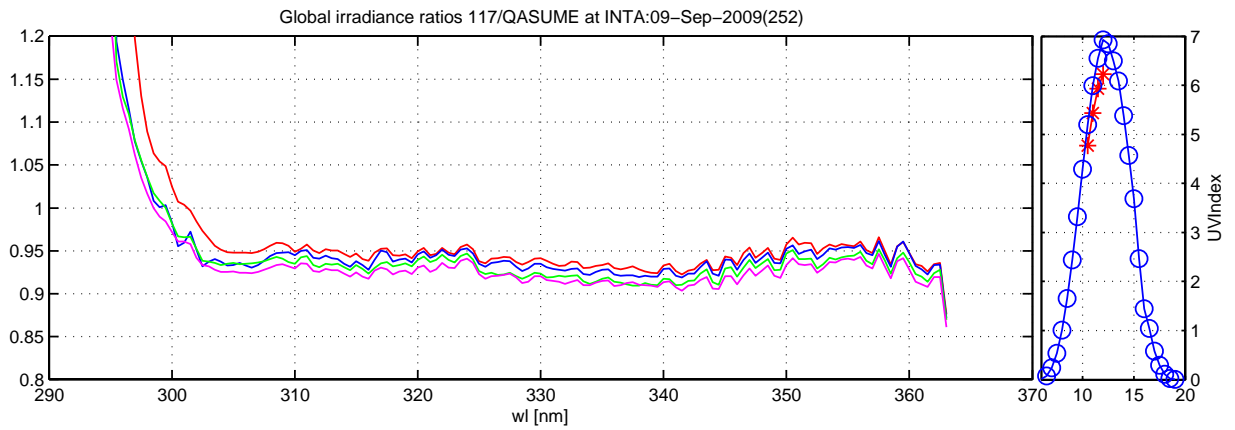
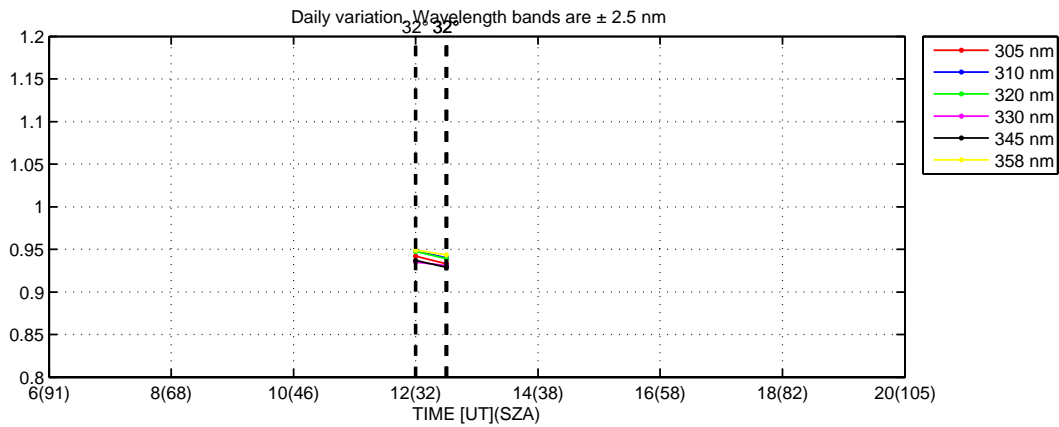
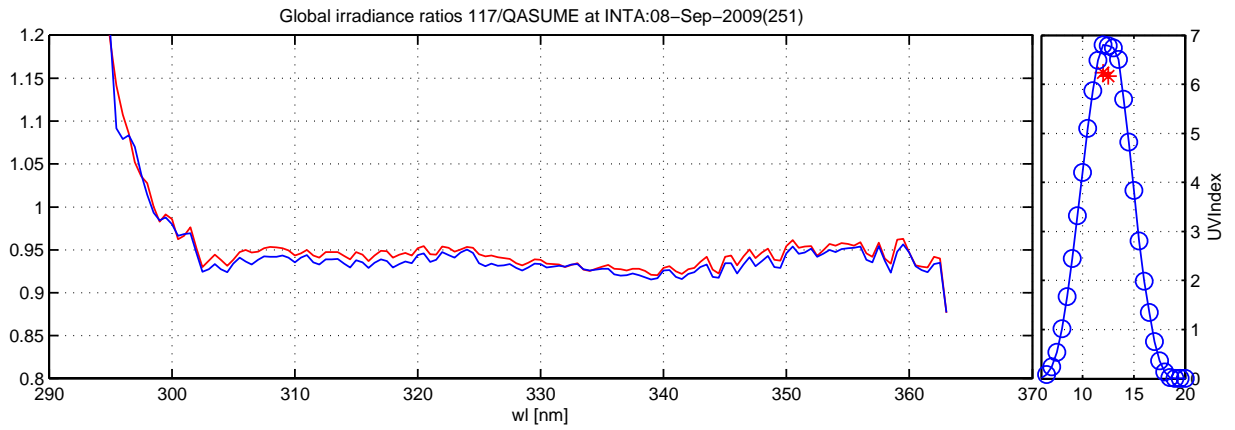

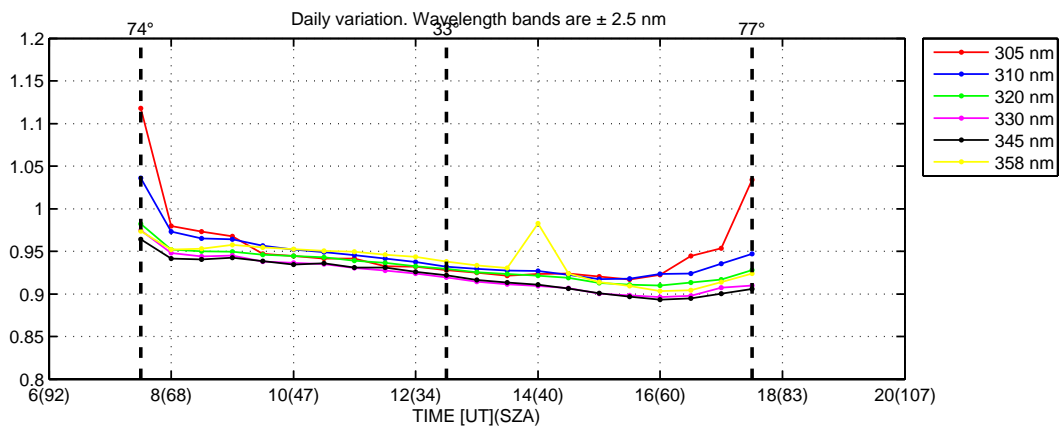
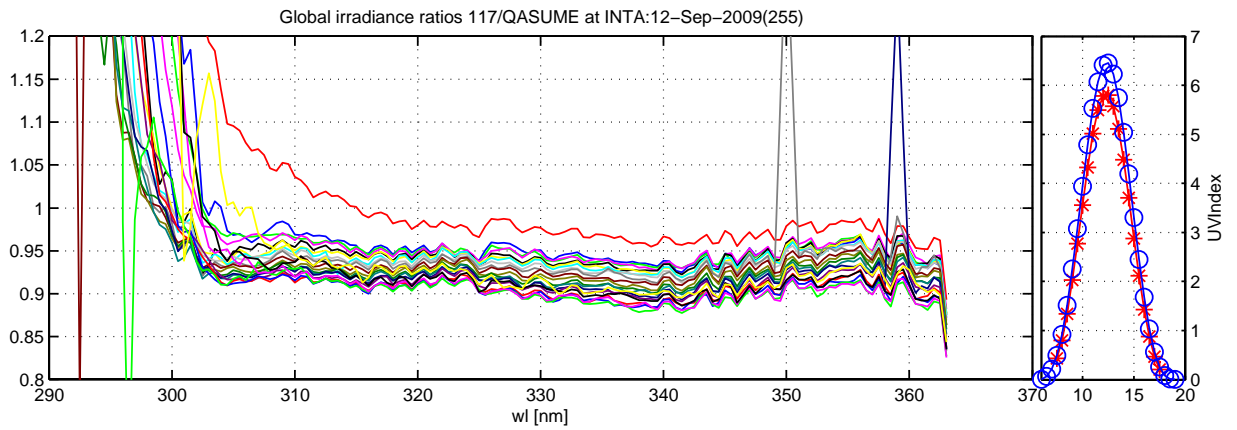
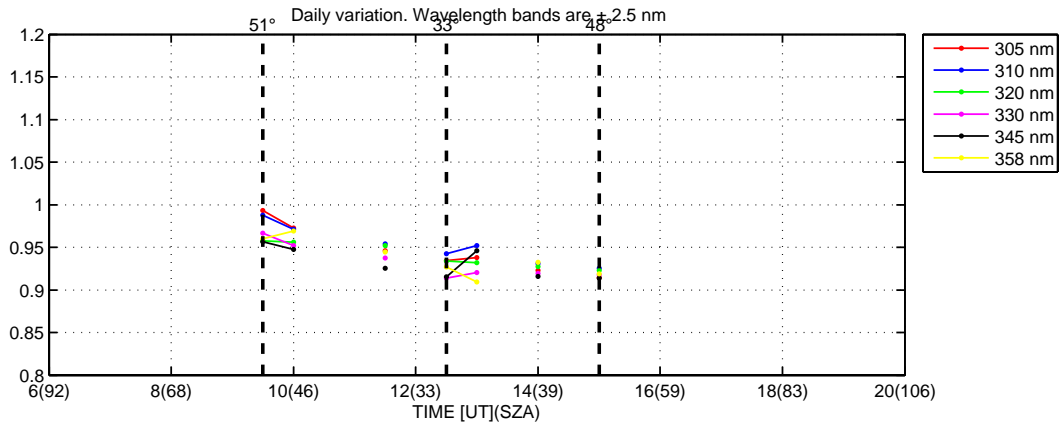
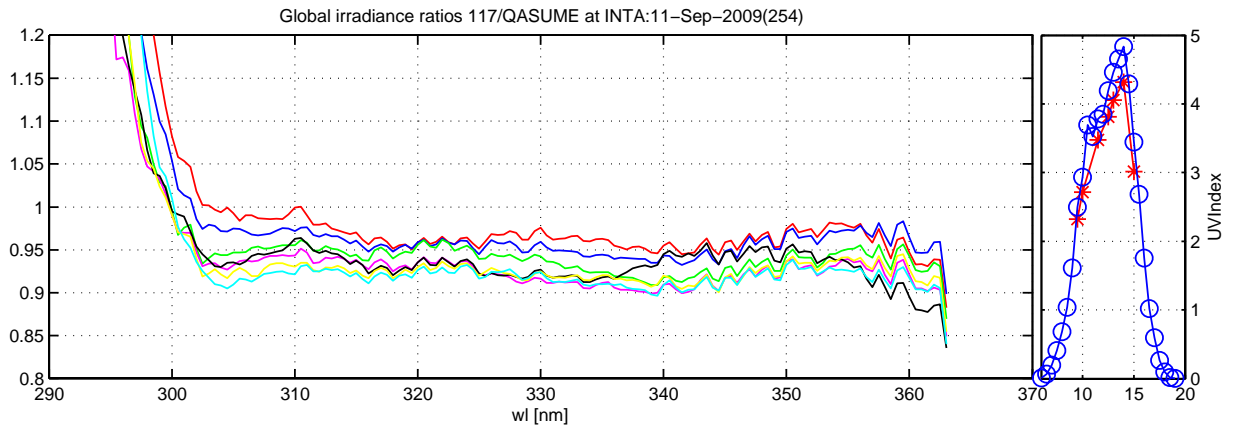

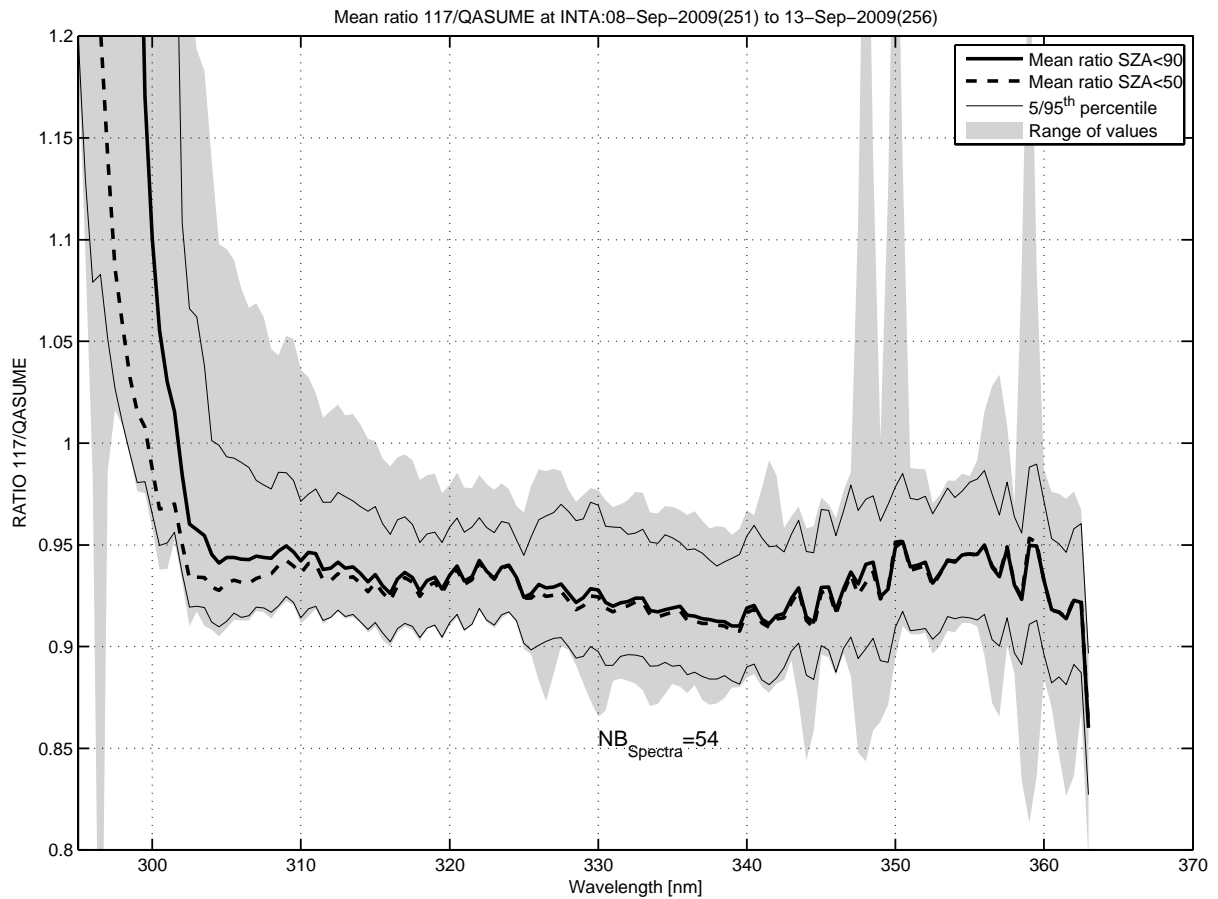
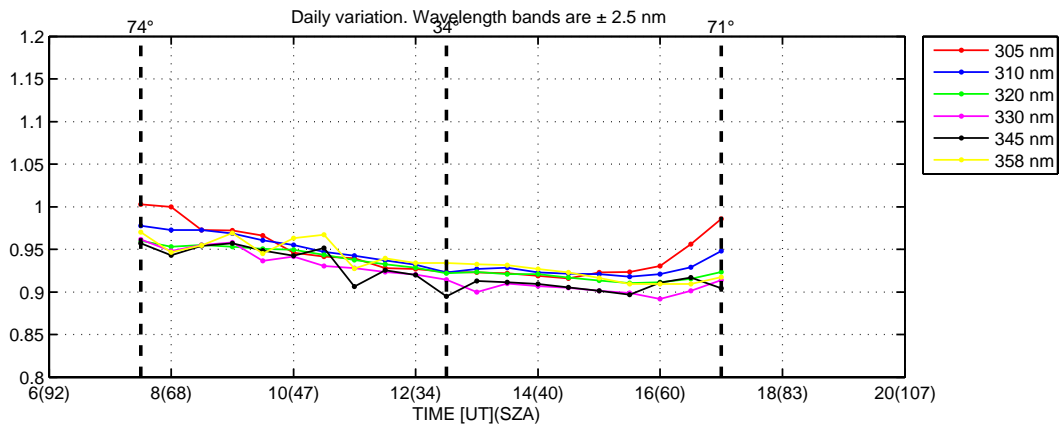
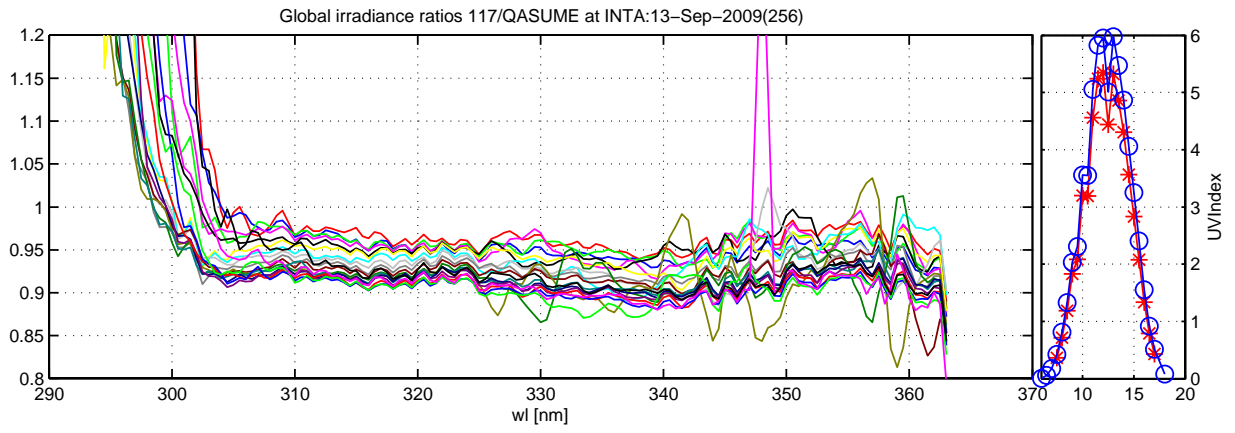

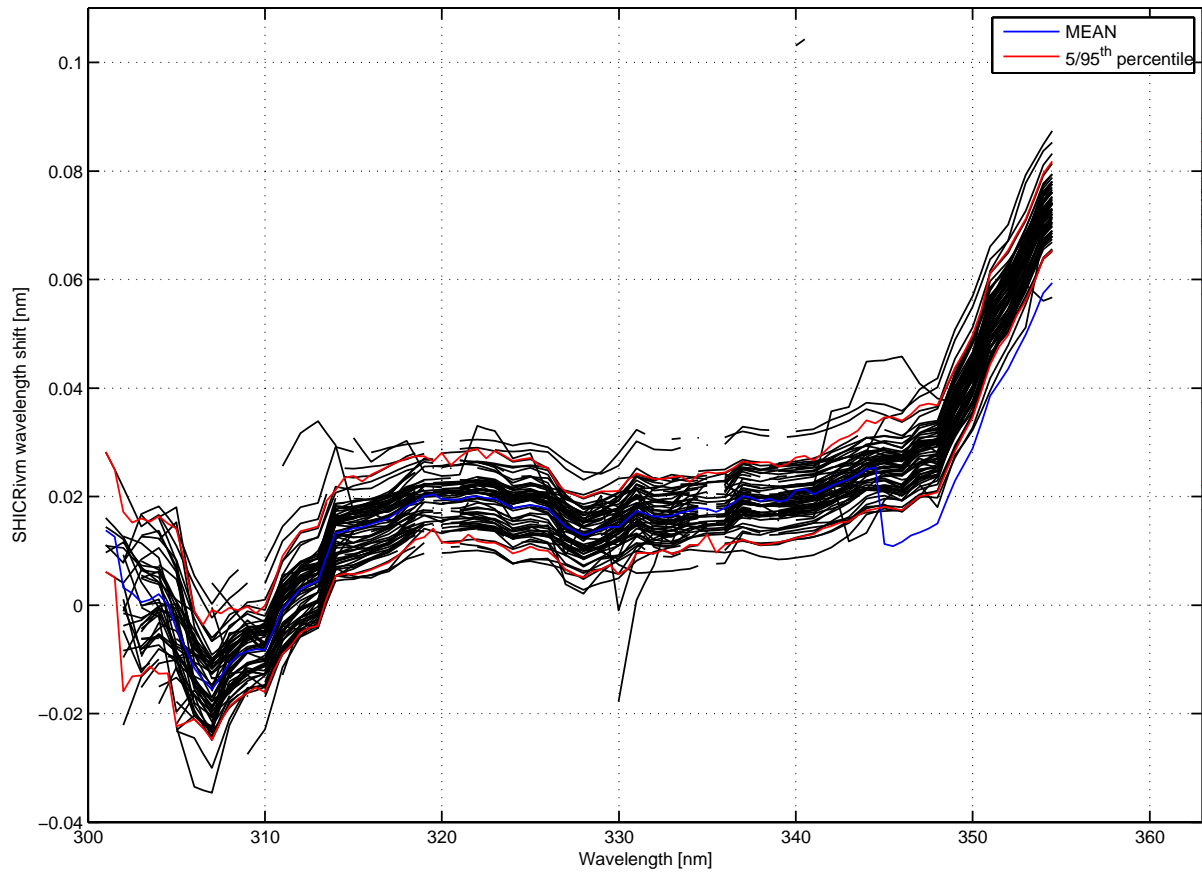

UV Index INTA, September 2009

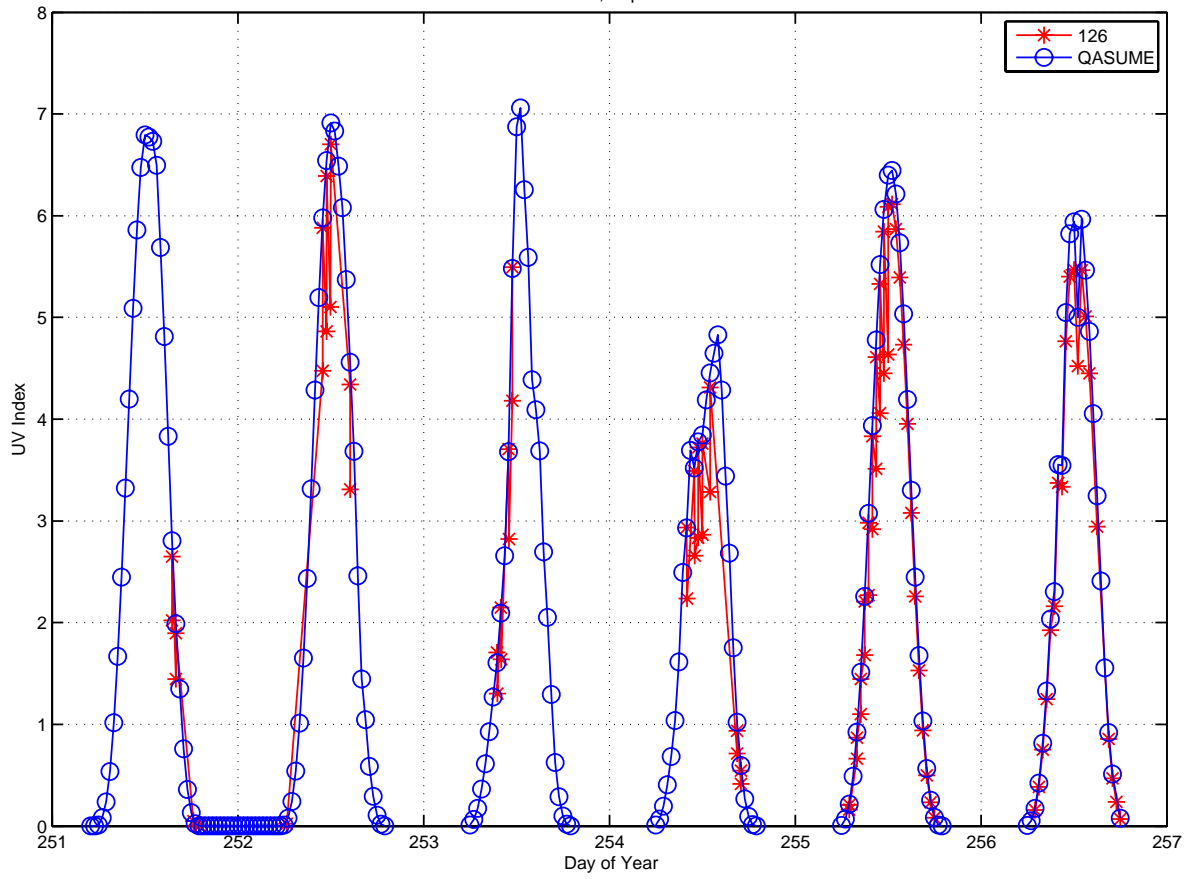

Global irradiance ratios 126/QASUME at INTA:08-Sep-2009(251) to 13-Sep-2009(256)

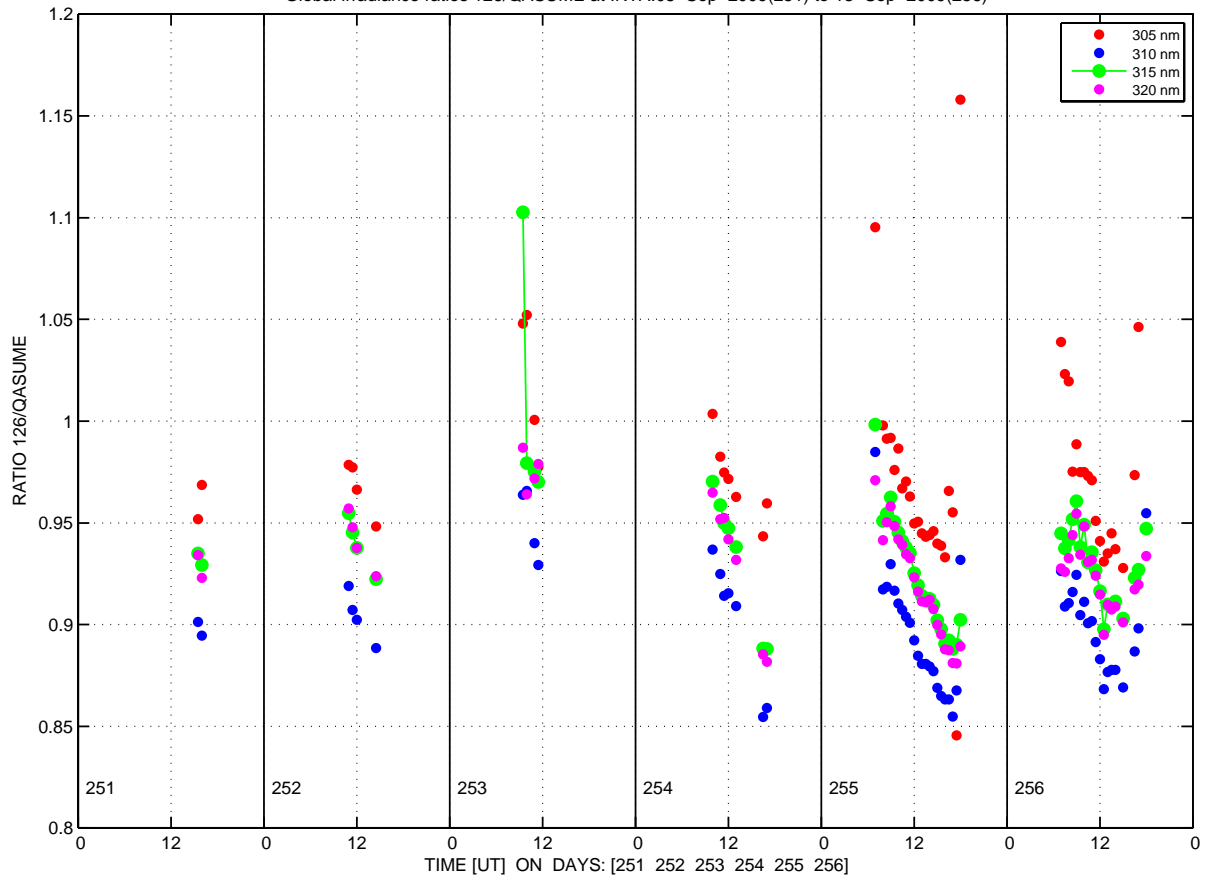



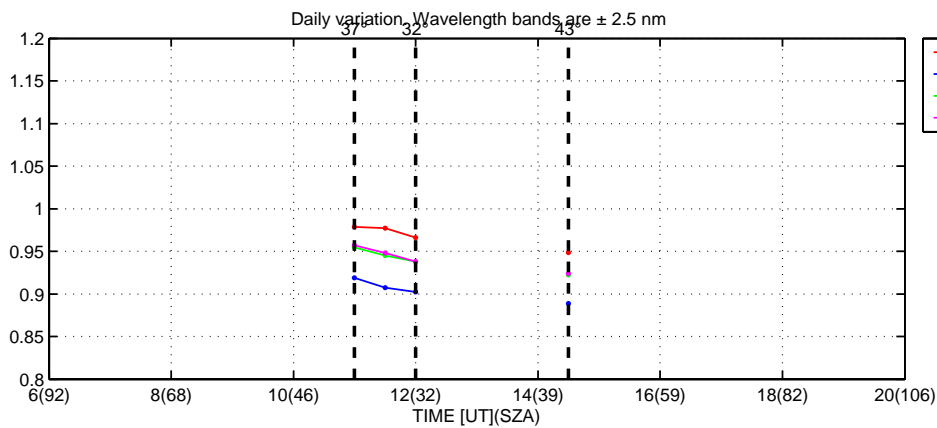
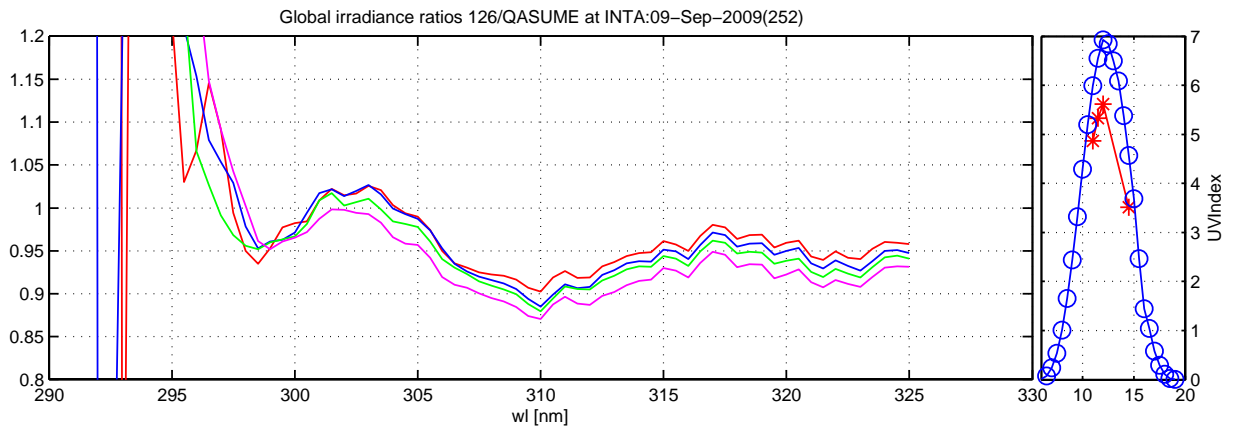
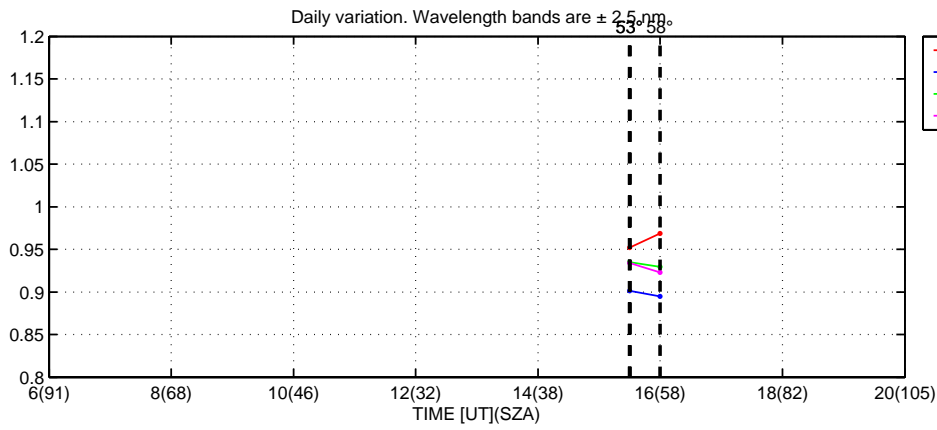
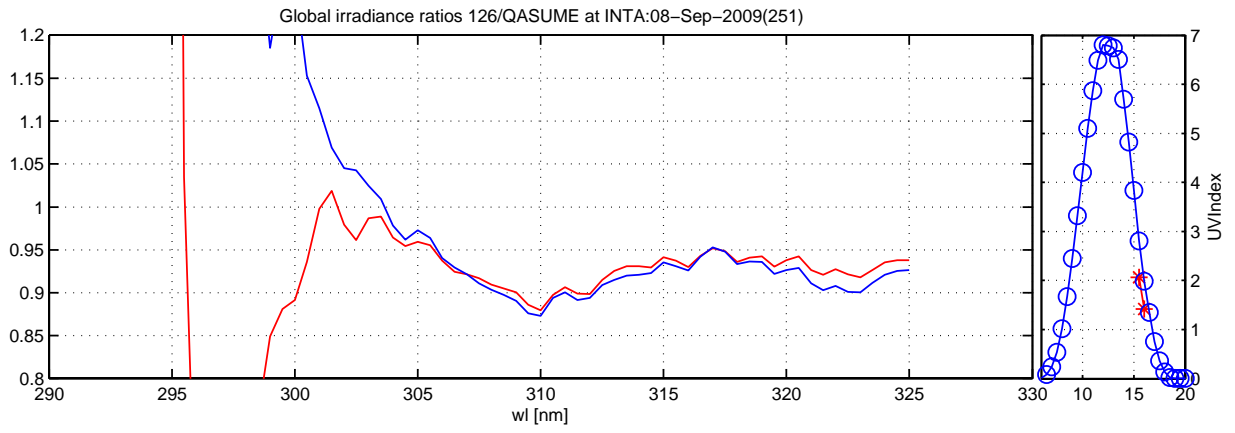

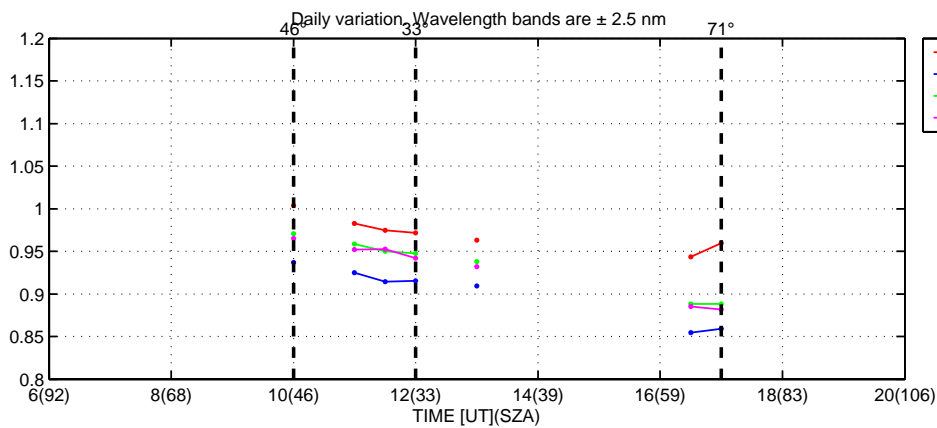
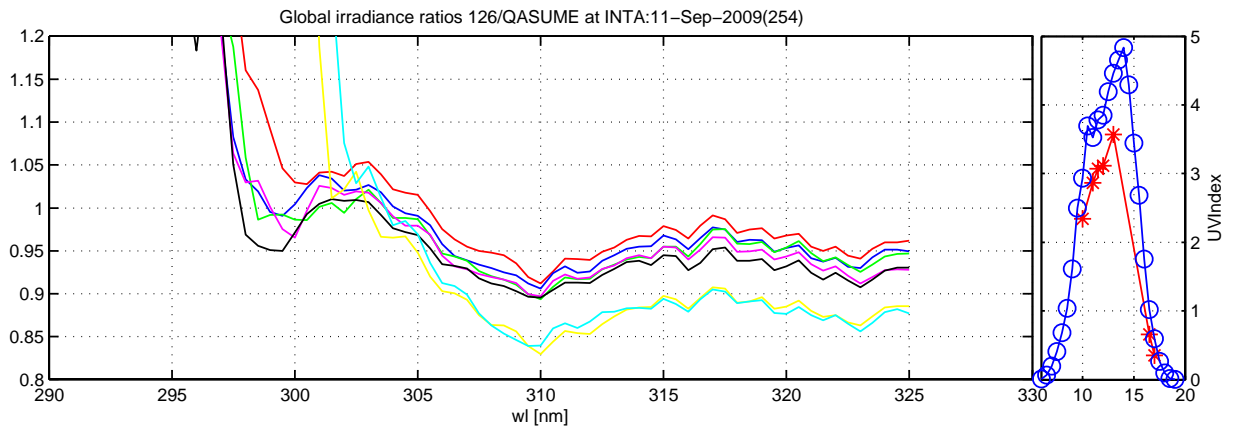
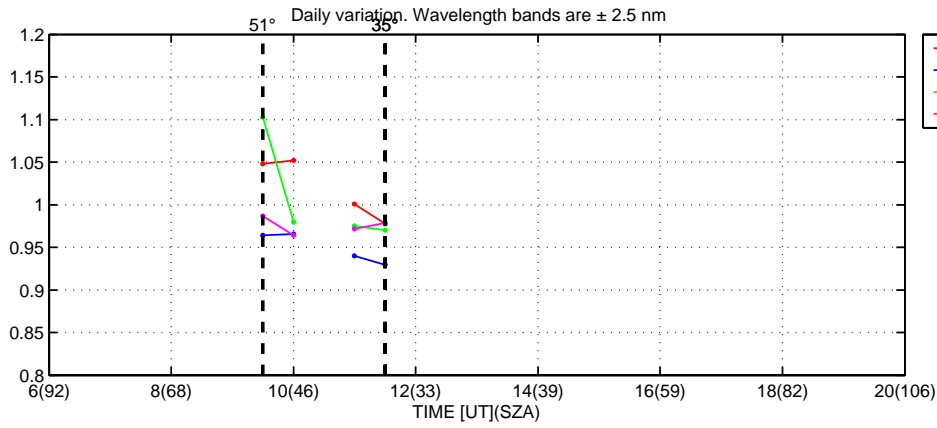
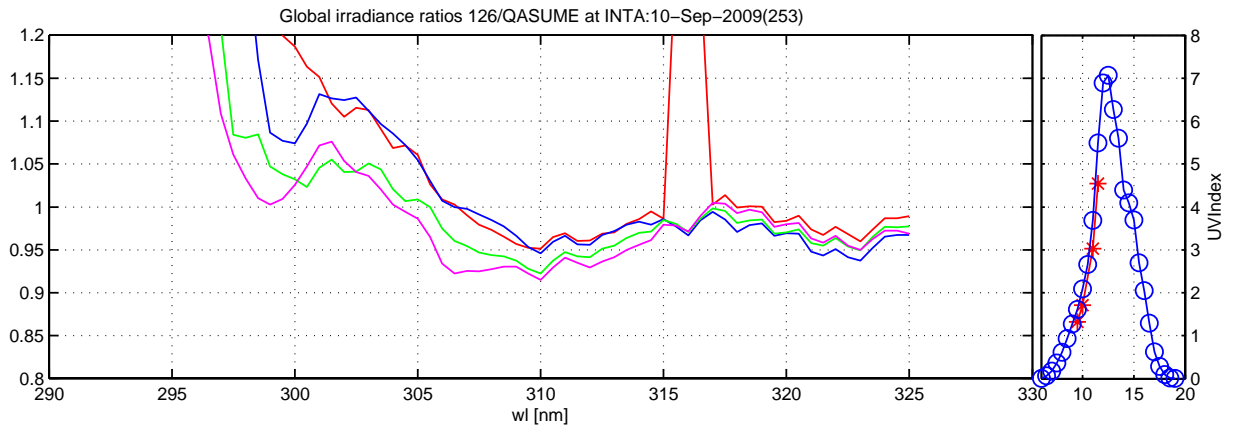

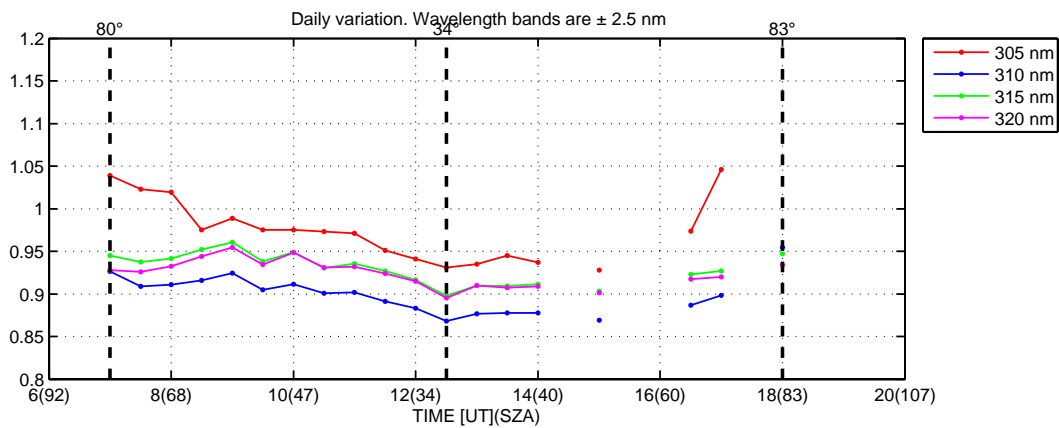
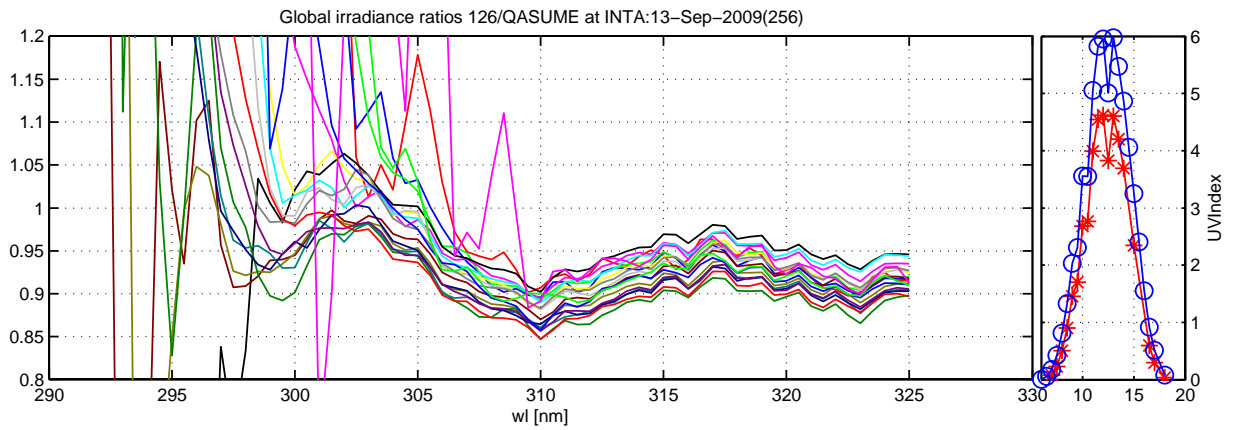
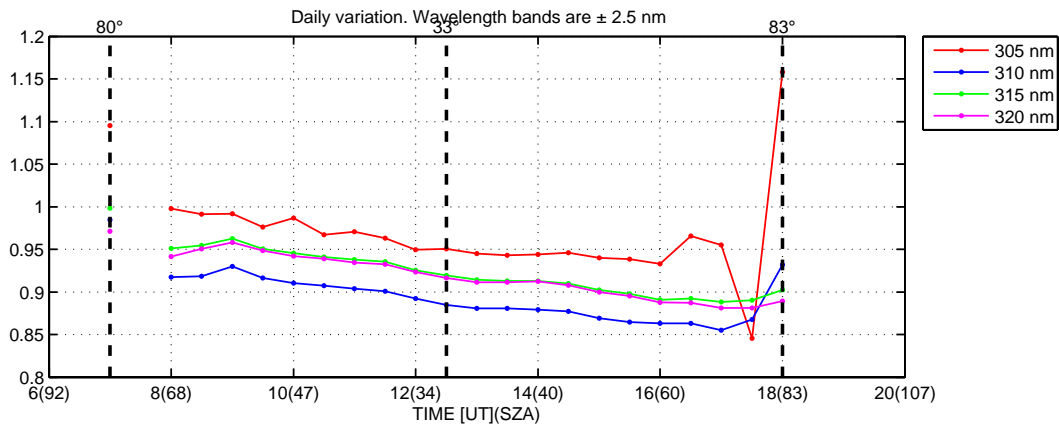
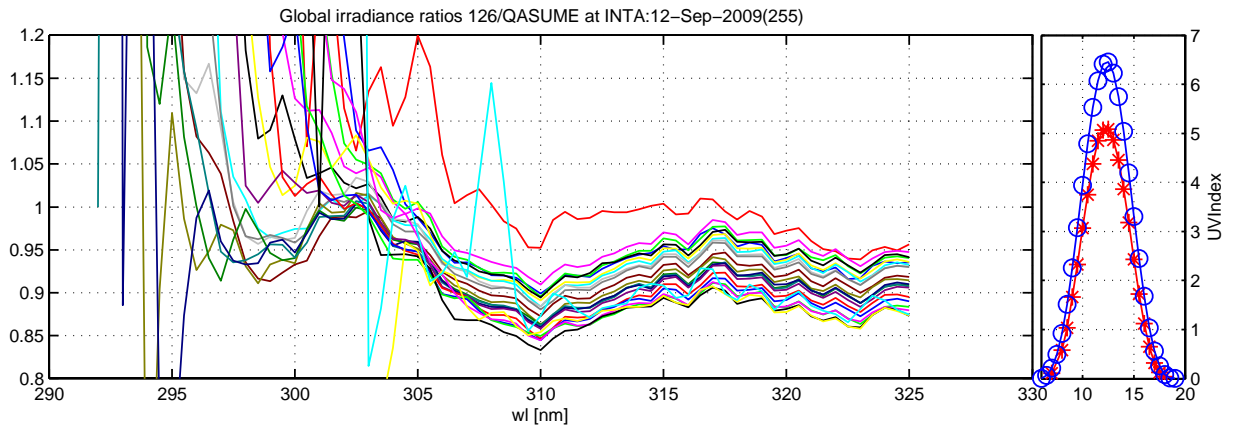

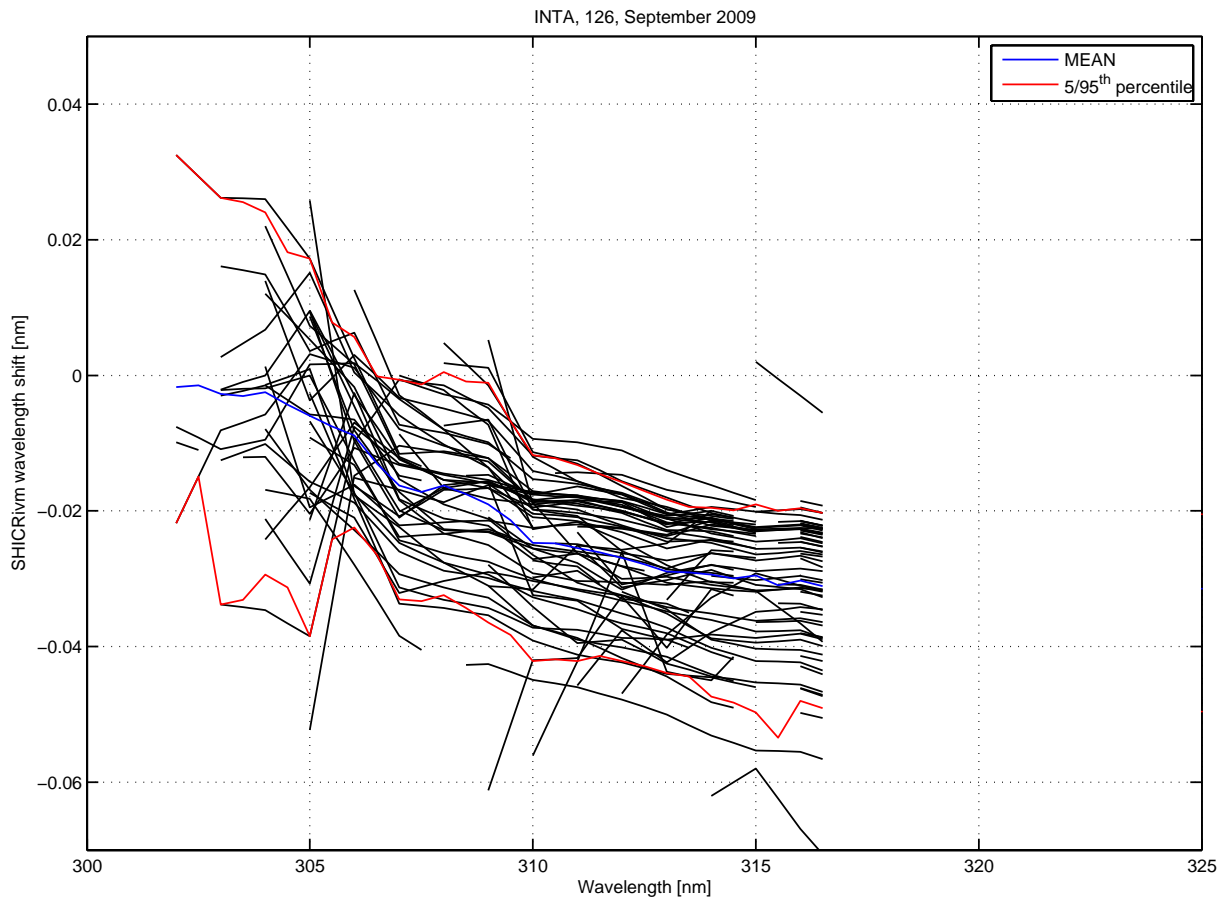
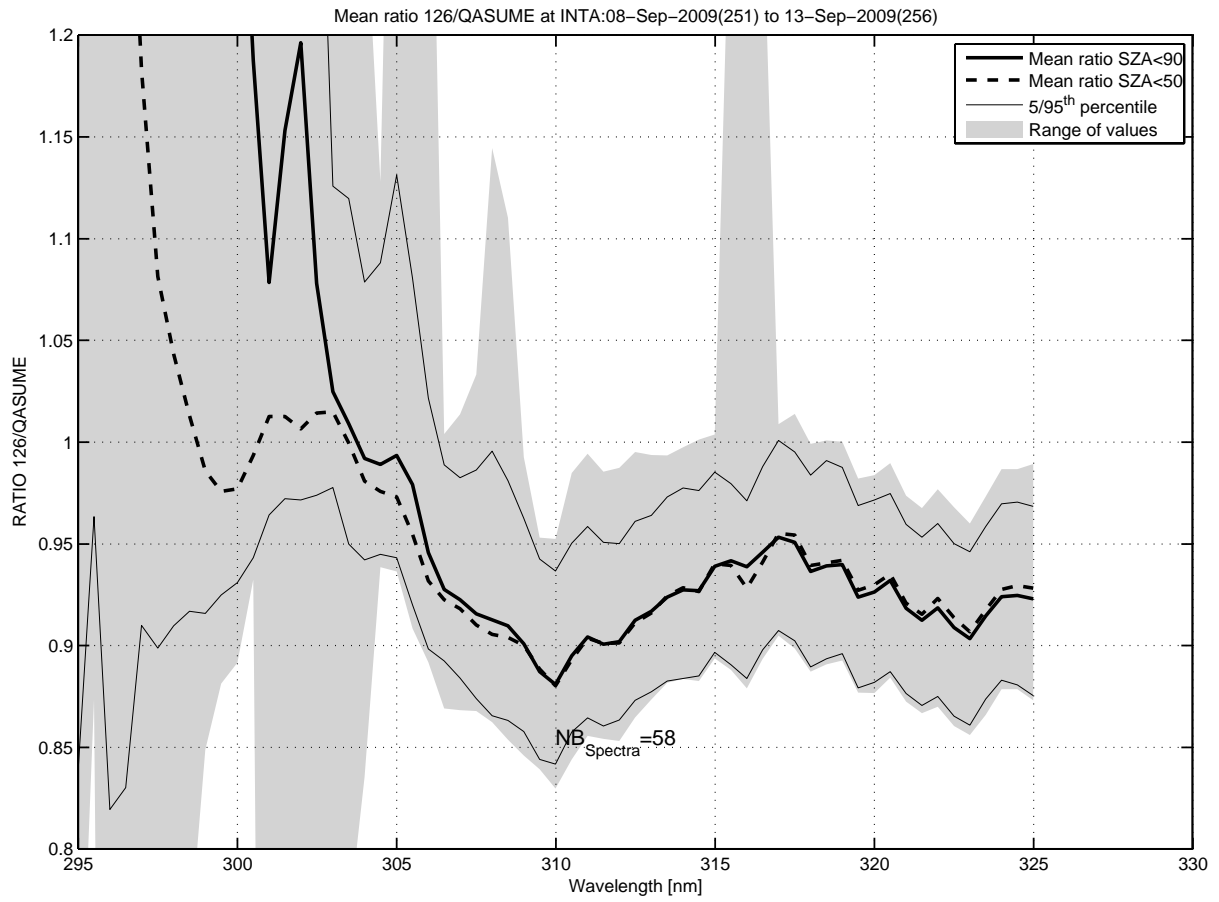

UV Index INTA, September 2009

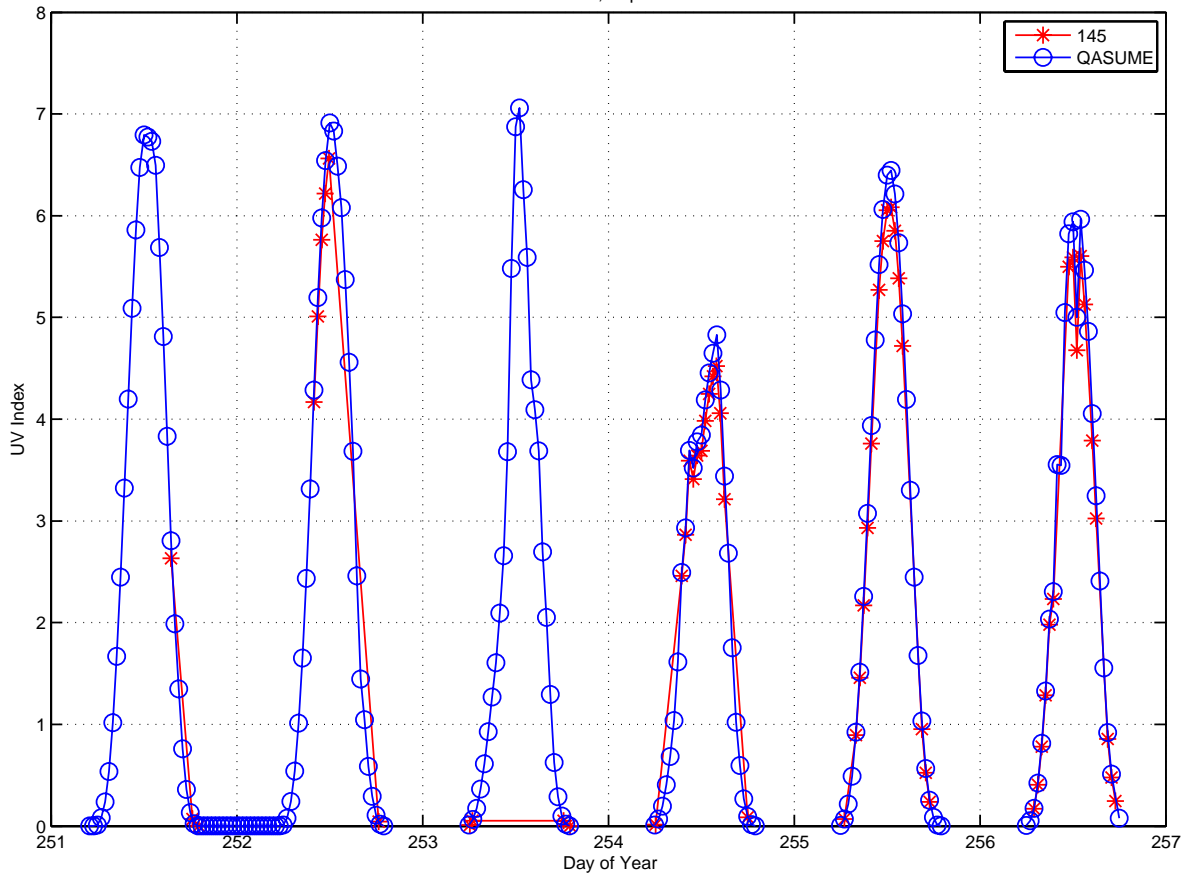

Global irradiance ratios 145/QASUME at INTA:09-Sep-2009(252) to 13-Sep-2009(256)

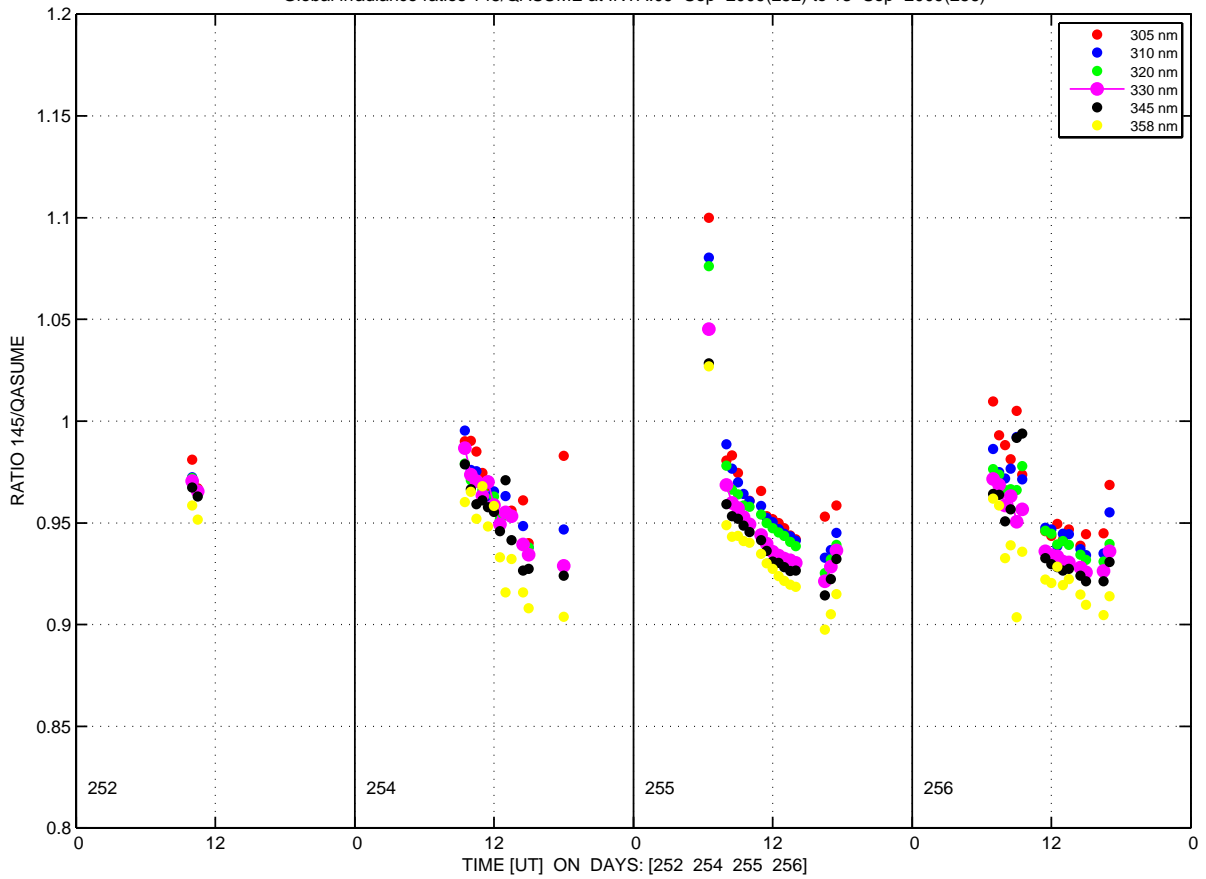

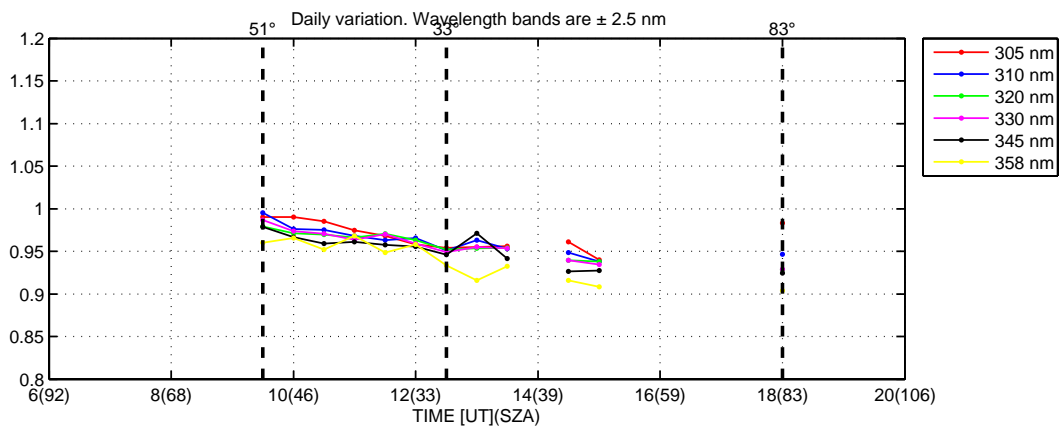
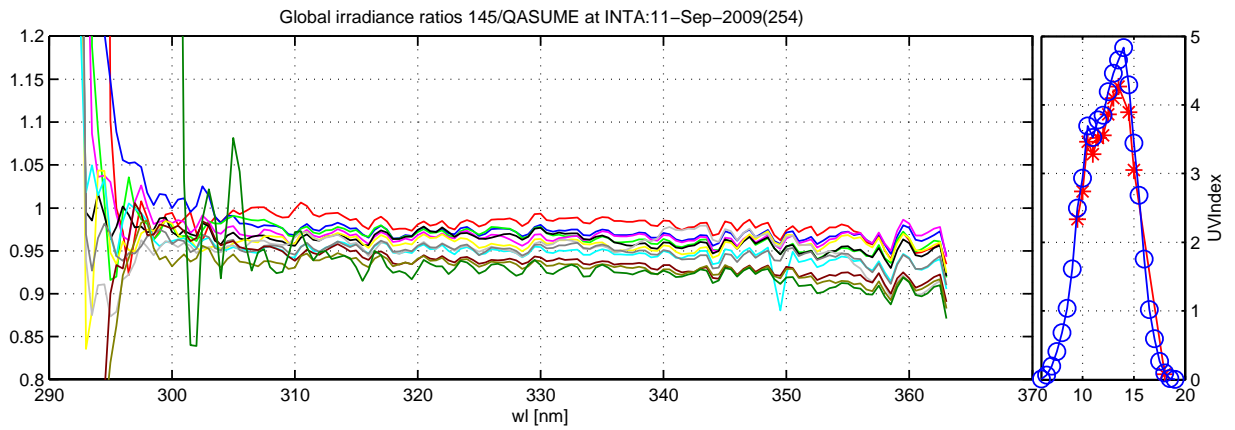
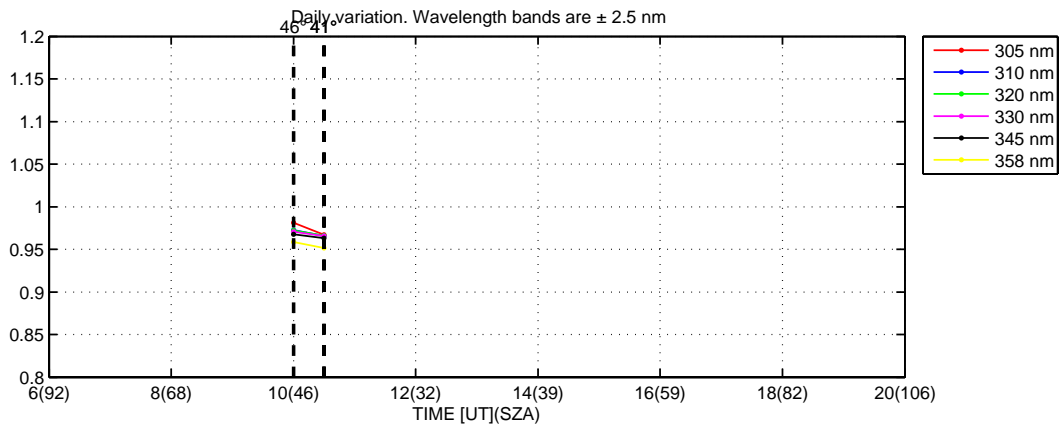
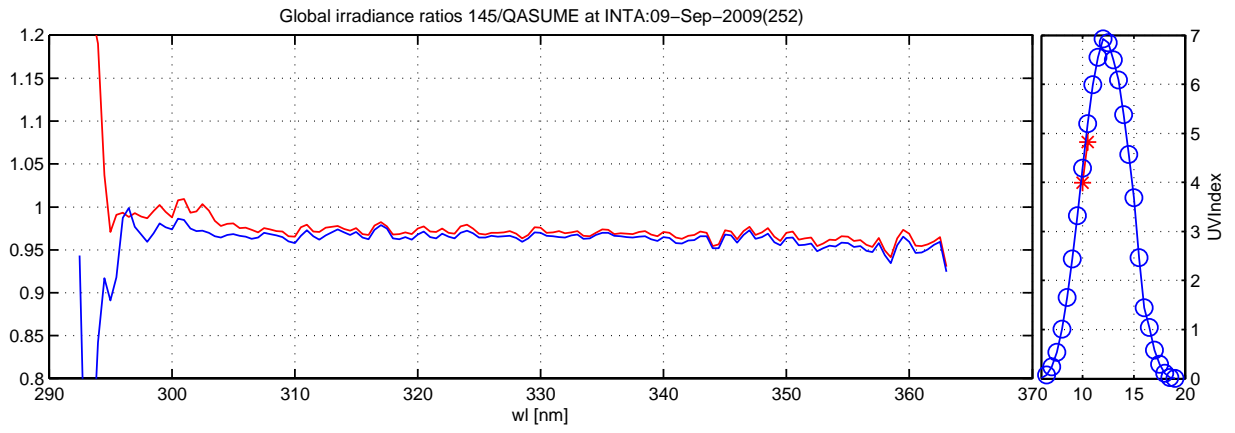

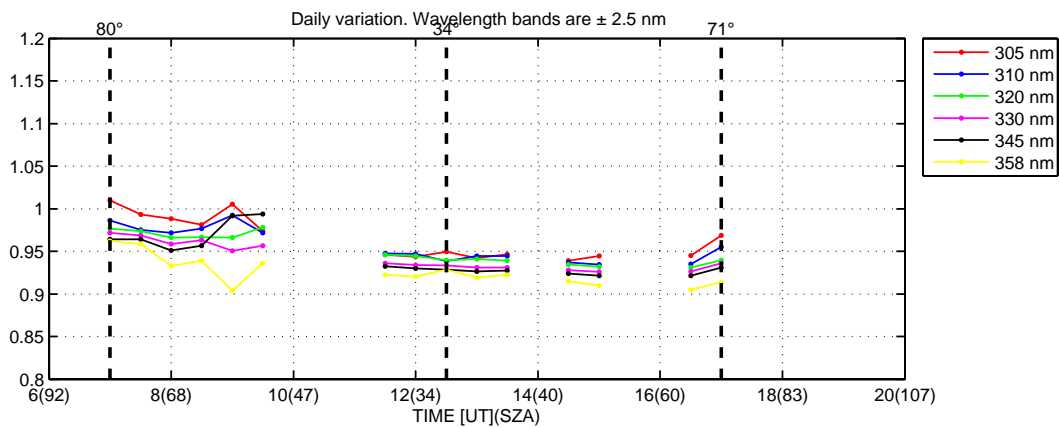
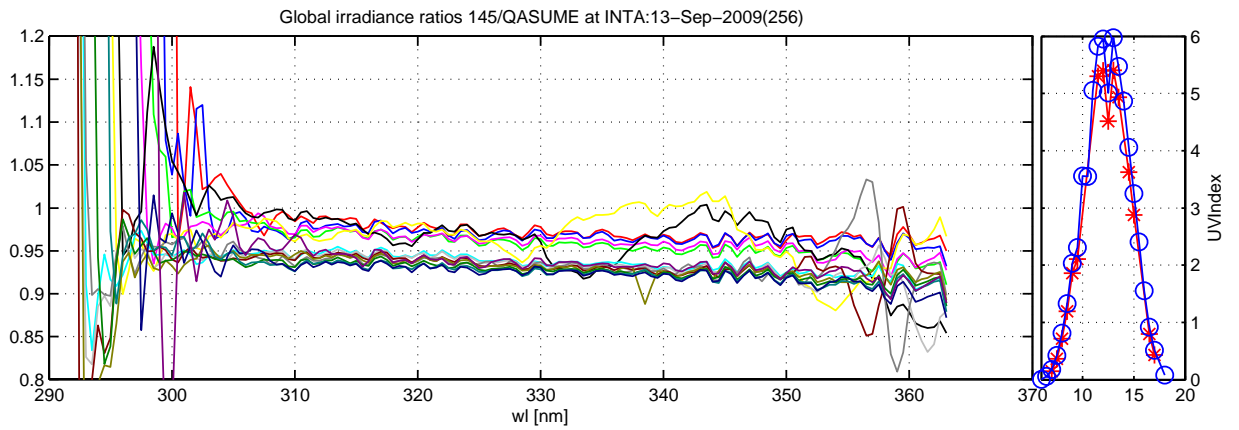
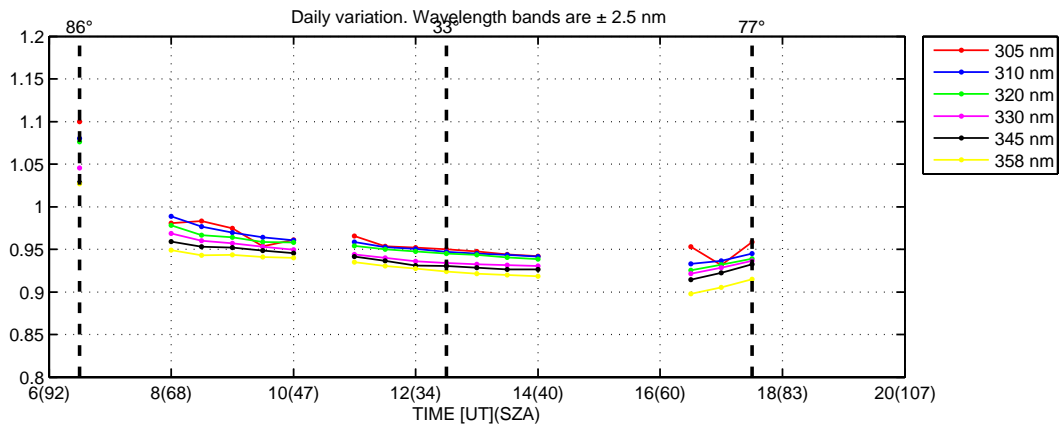
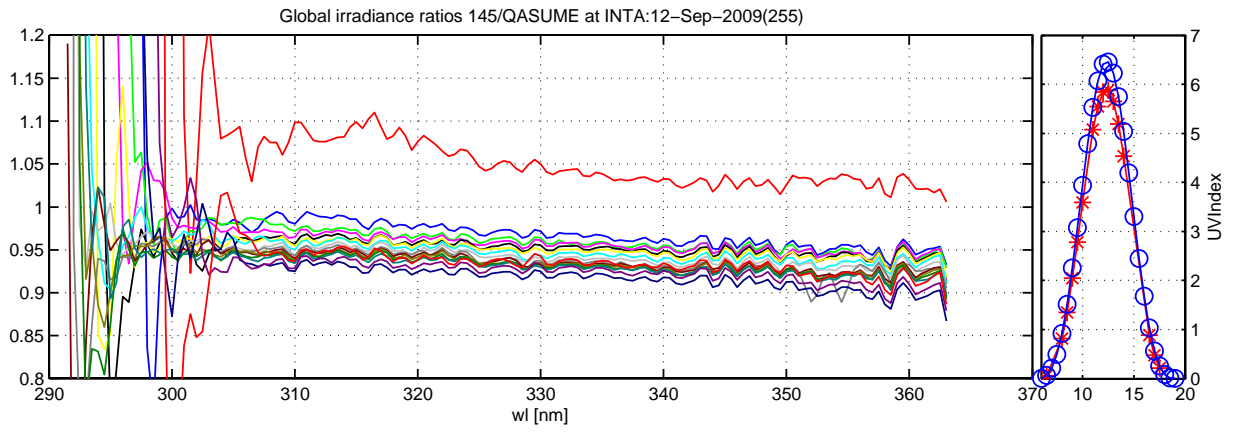

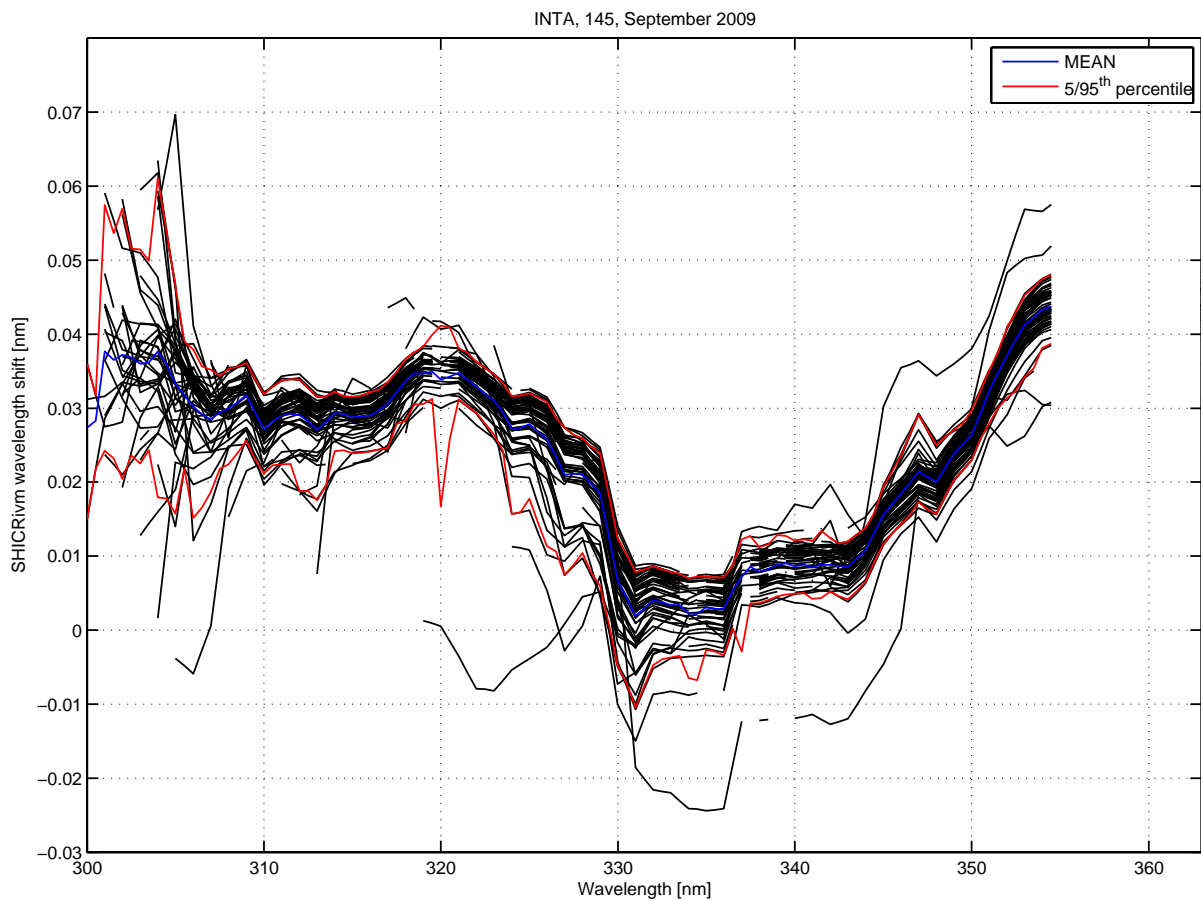
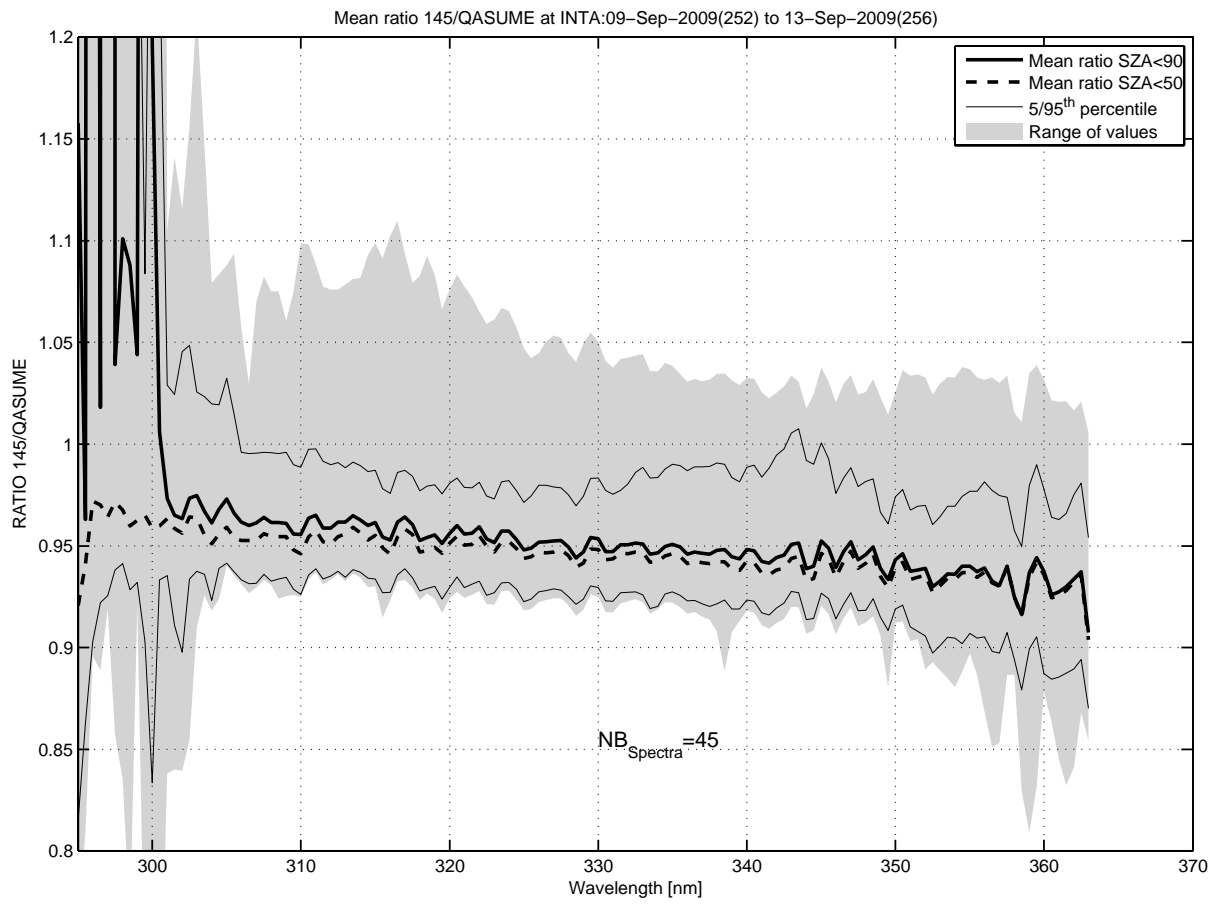



UV Index INTA, September 2009

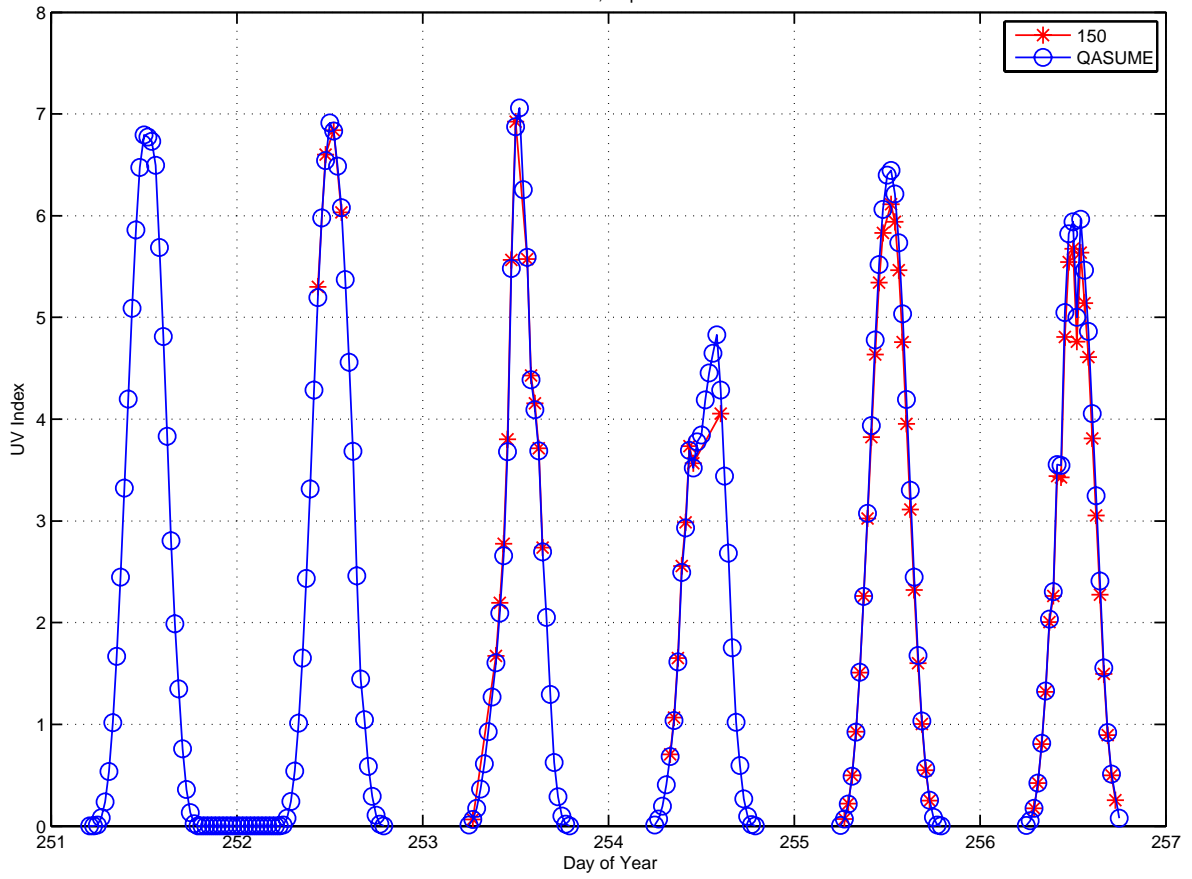

Global irradiance ratios 150/QASUME at INTA:09-Sep-2009(252) to 13-Sep-2009(256)

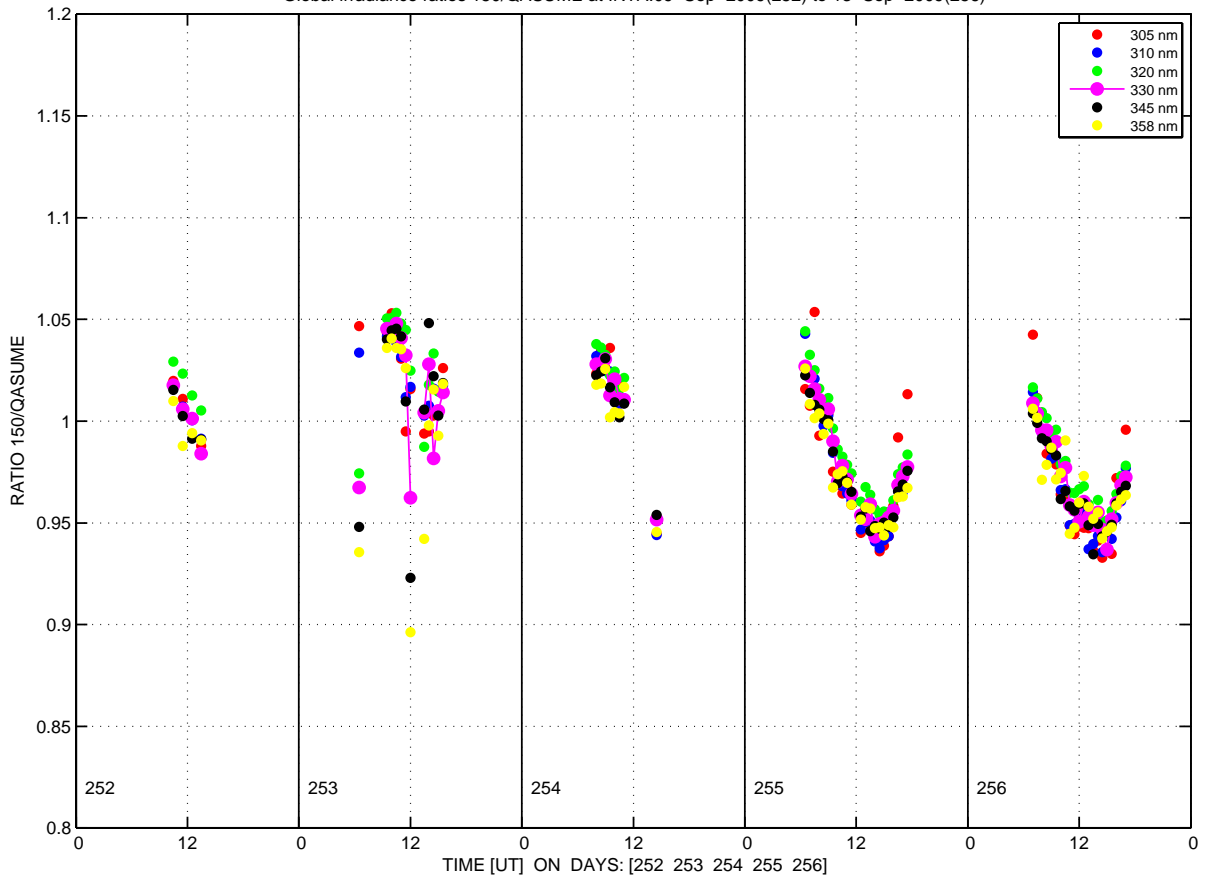

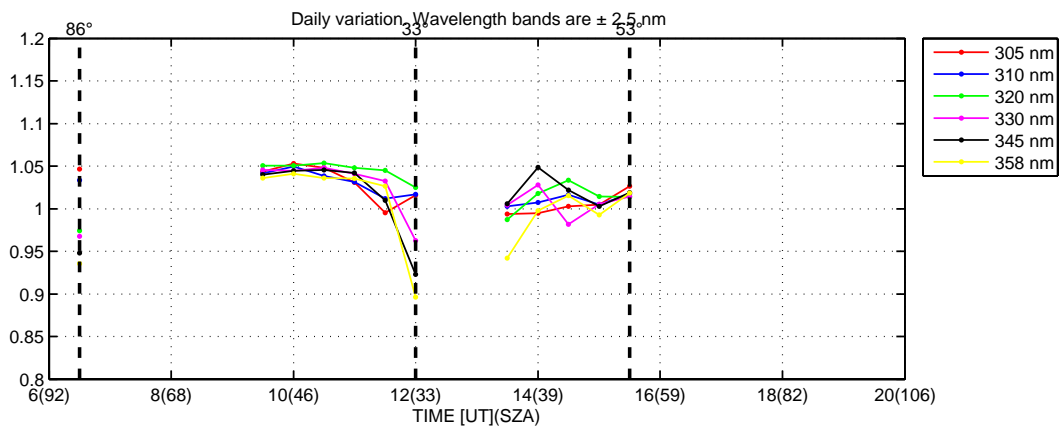
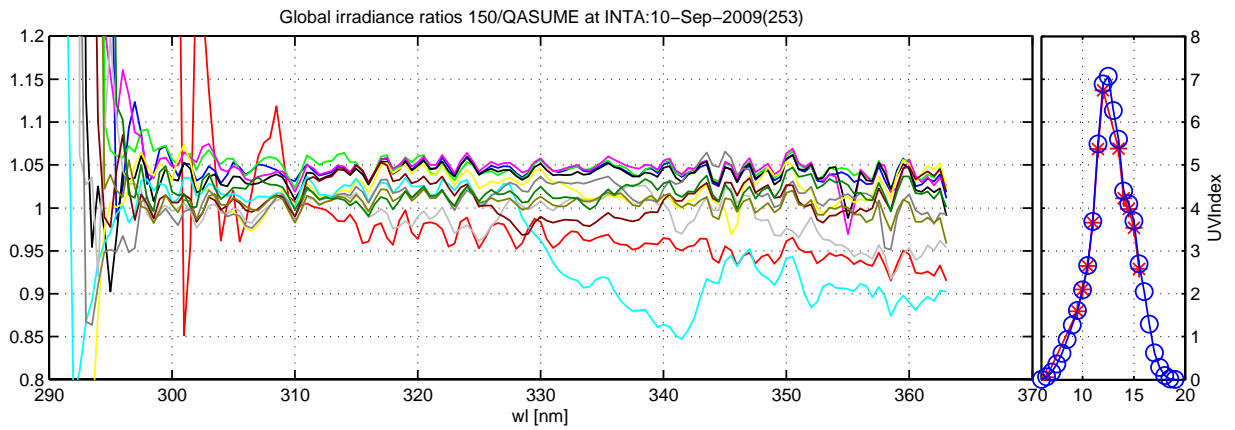
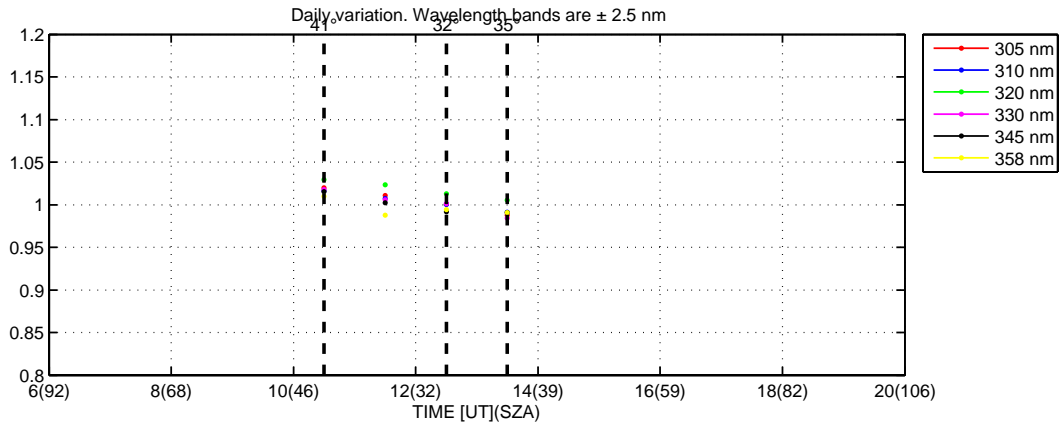
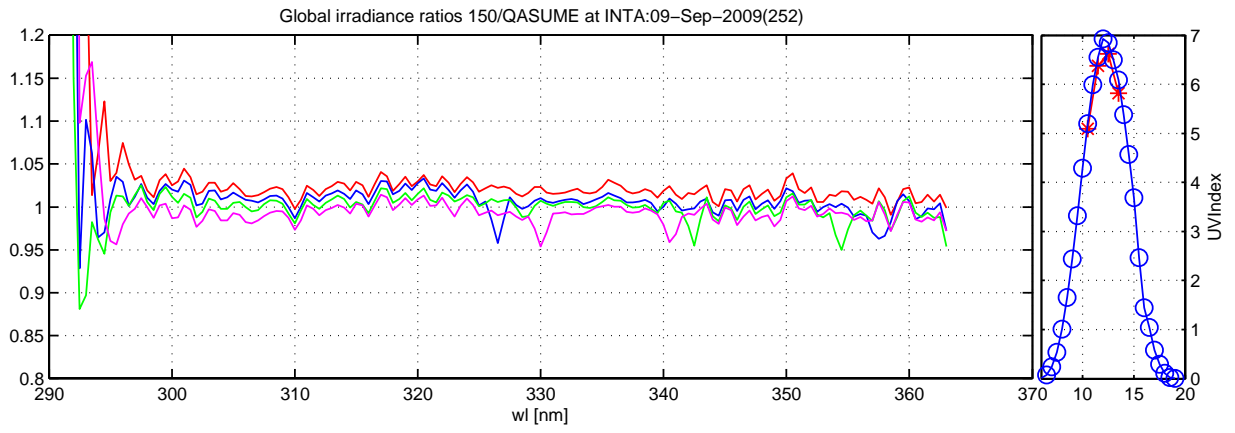

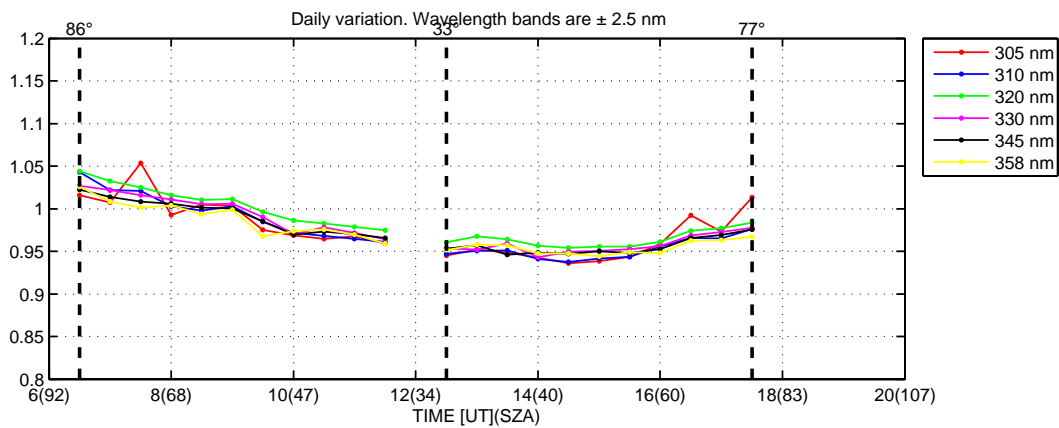
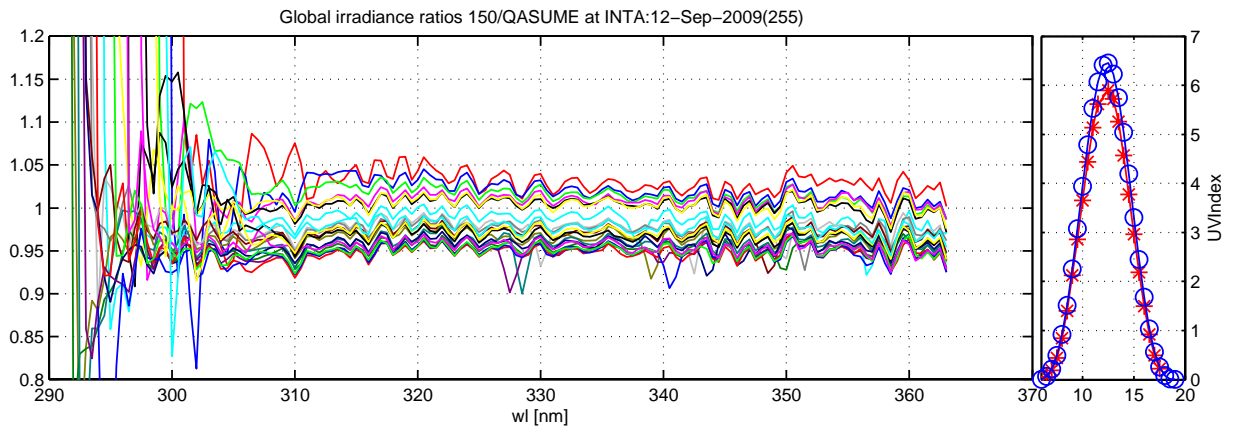
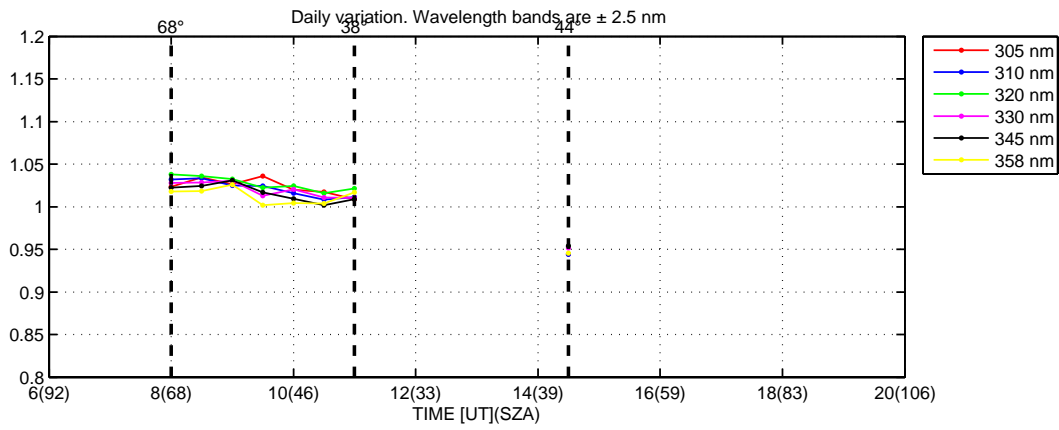
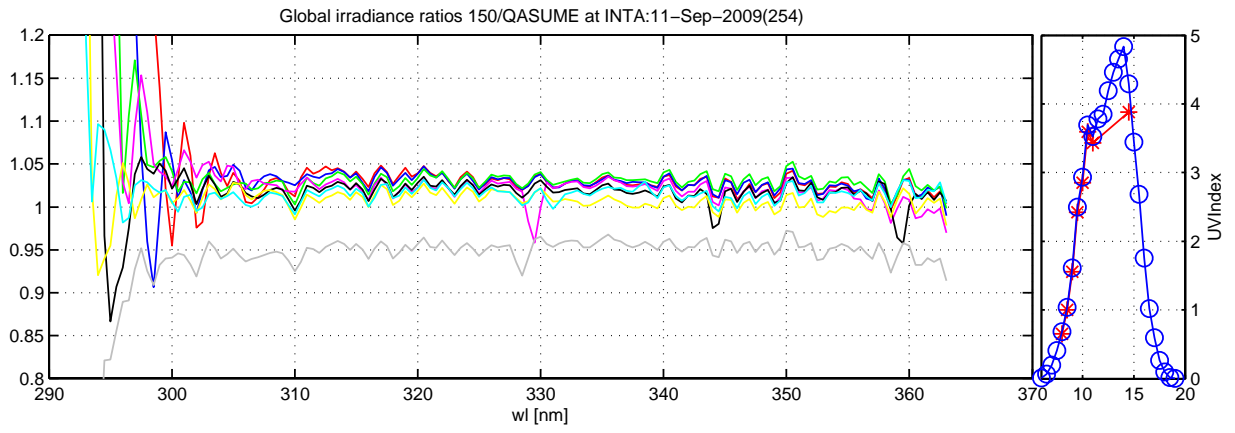

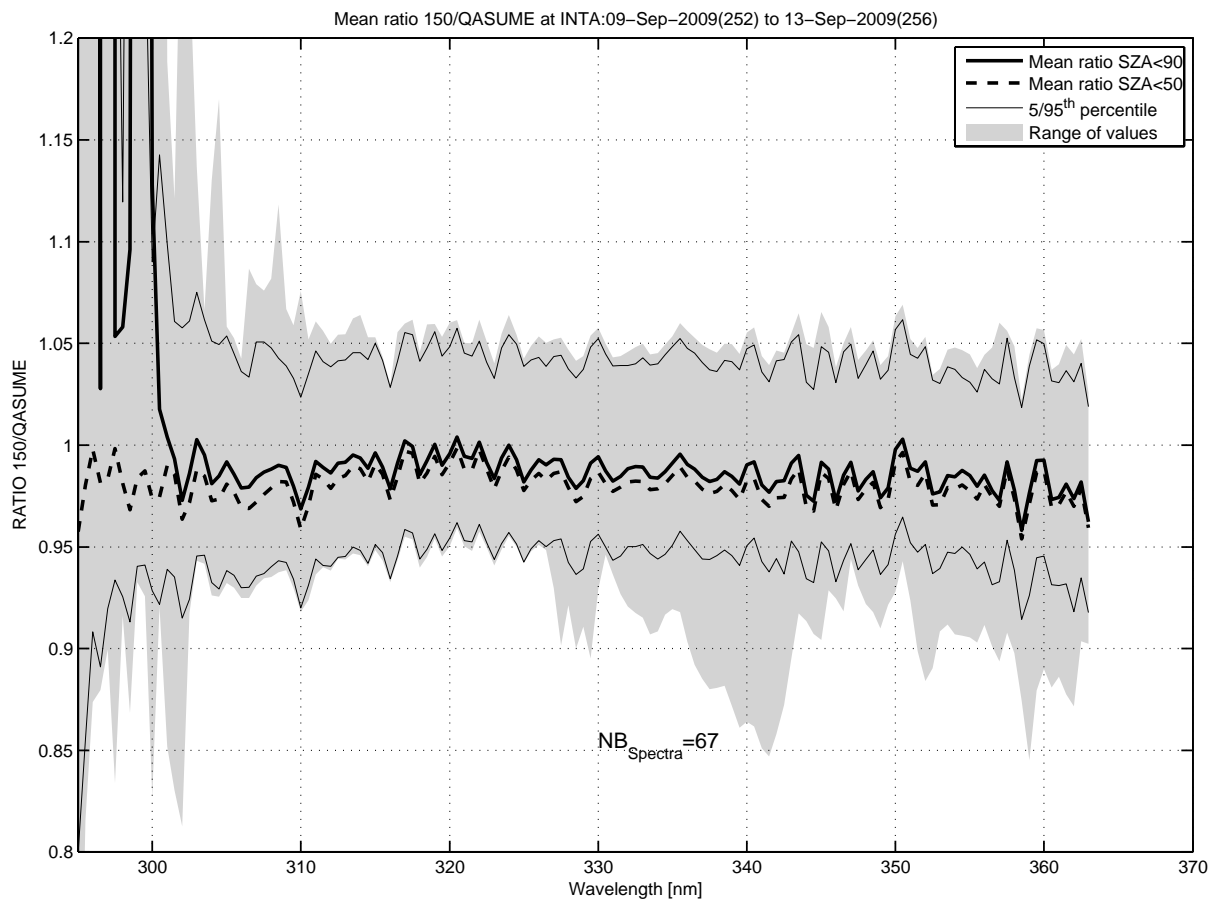
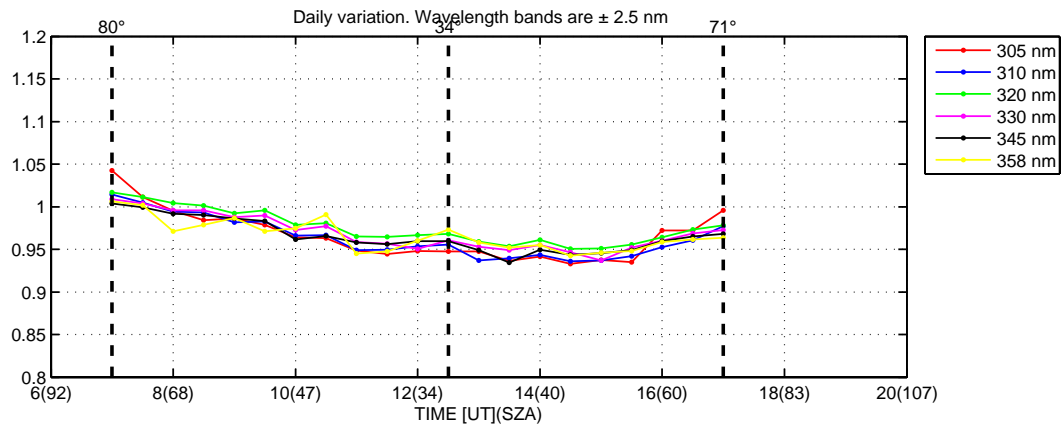
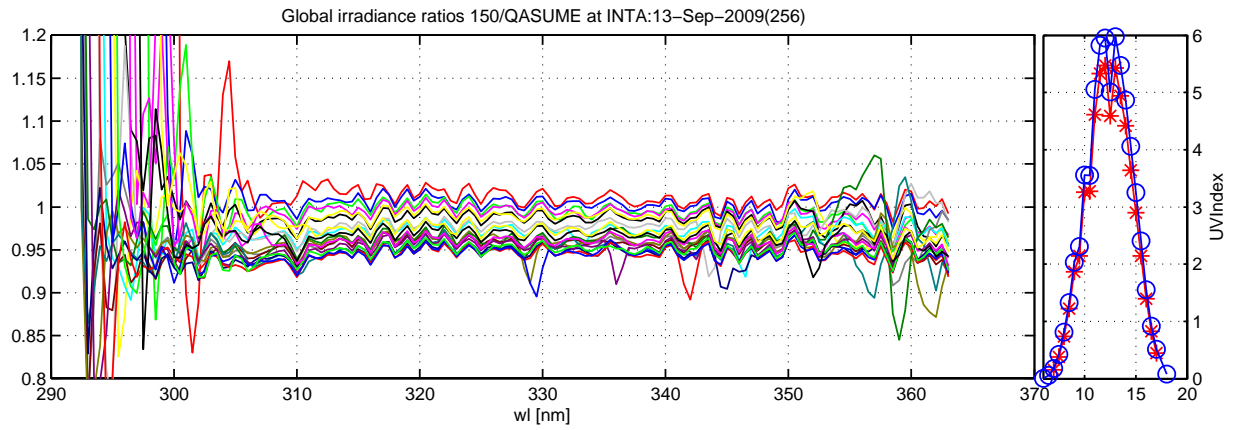

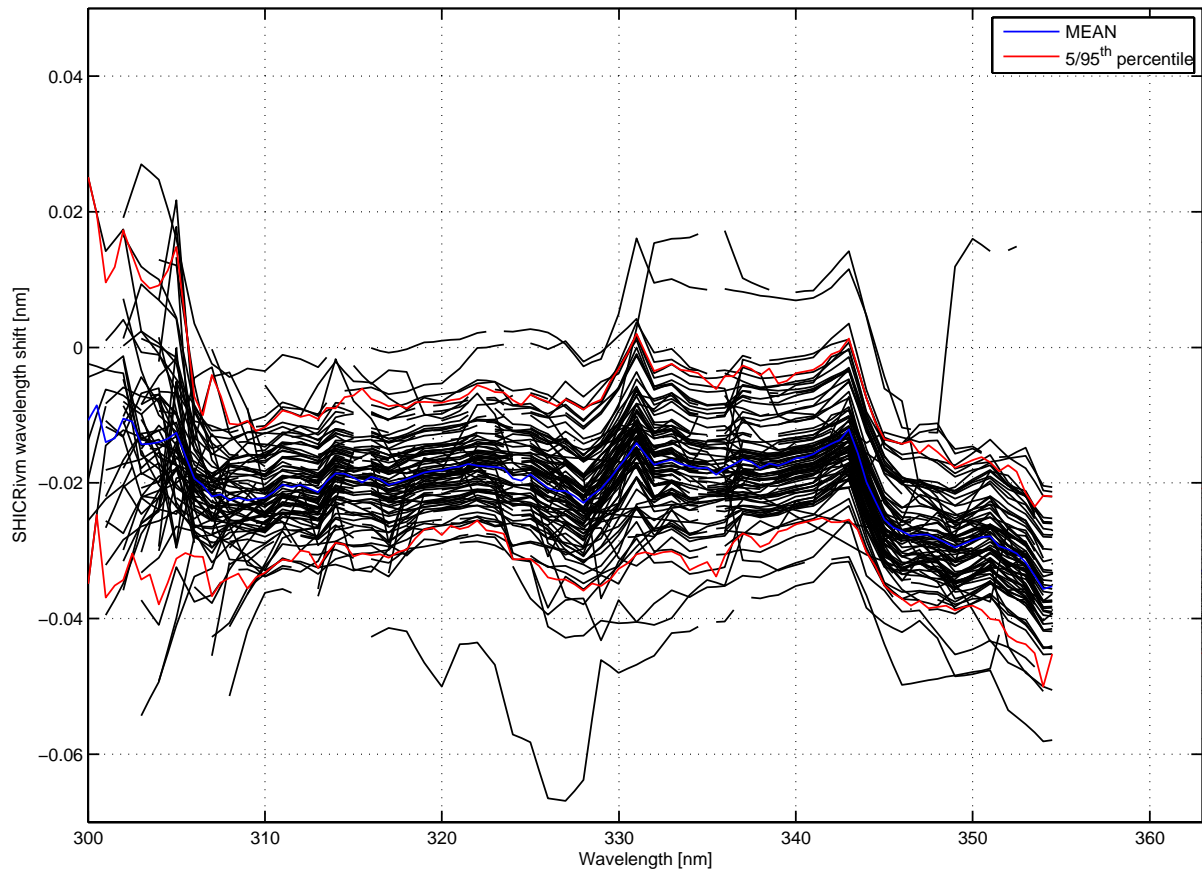

UV Index INTA, September 2009

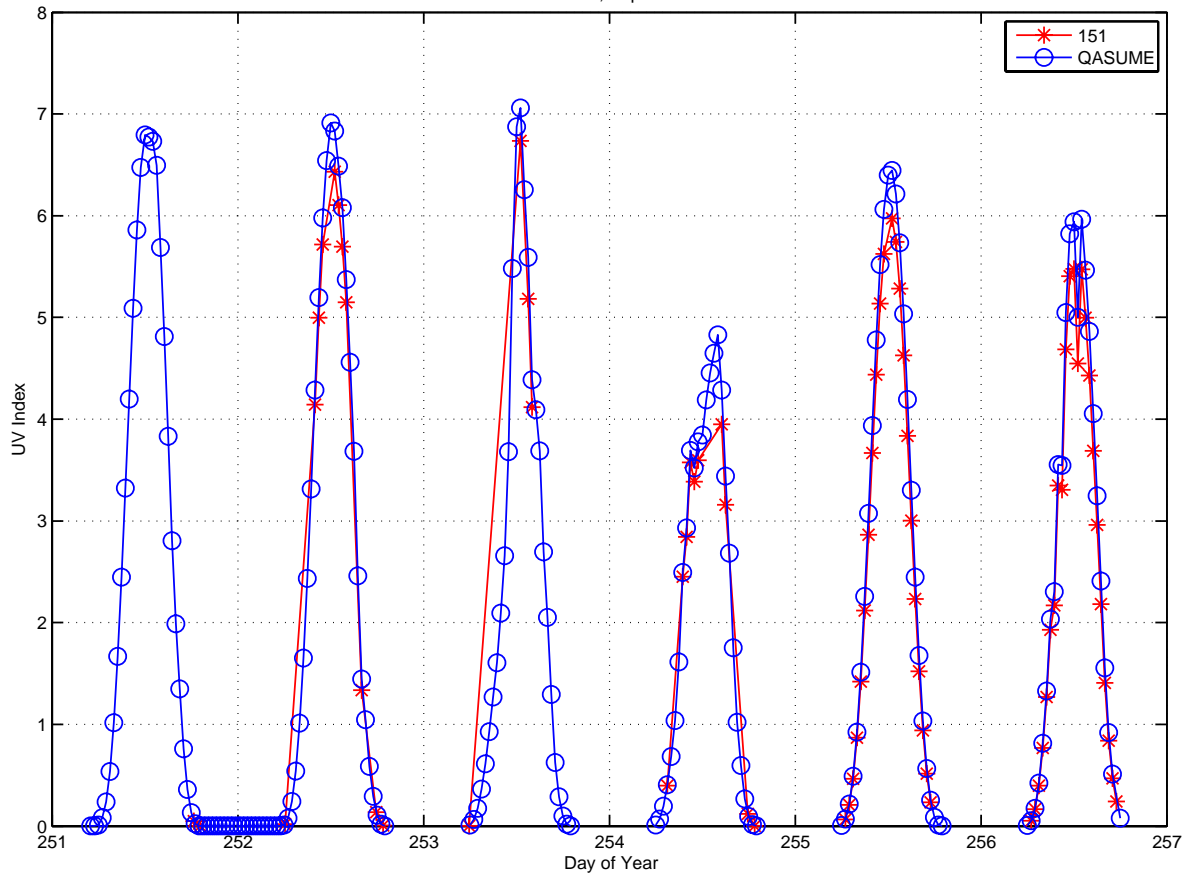

Global irradiance ratios 151/QASUME at INTA:09-Sep-2009(252) to 13-Sep-2009(256)

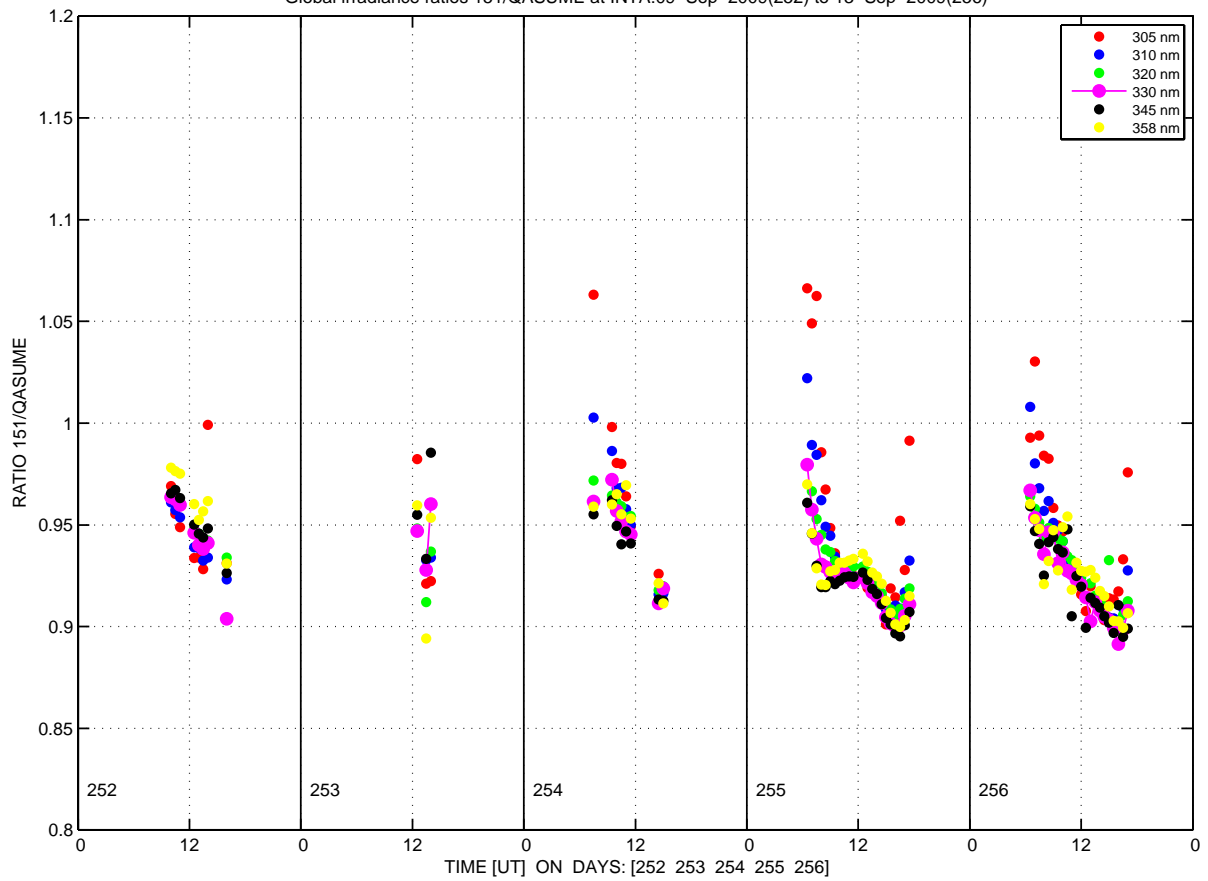

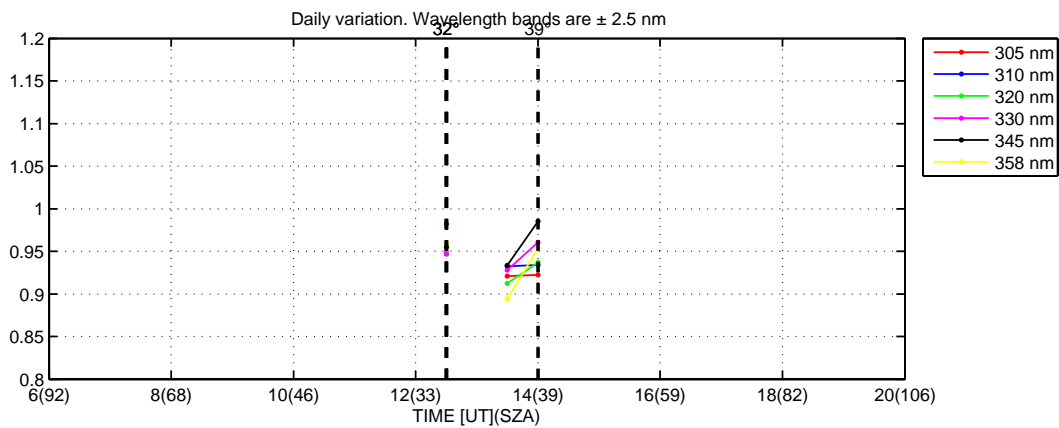
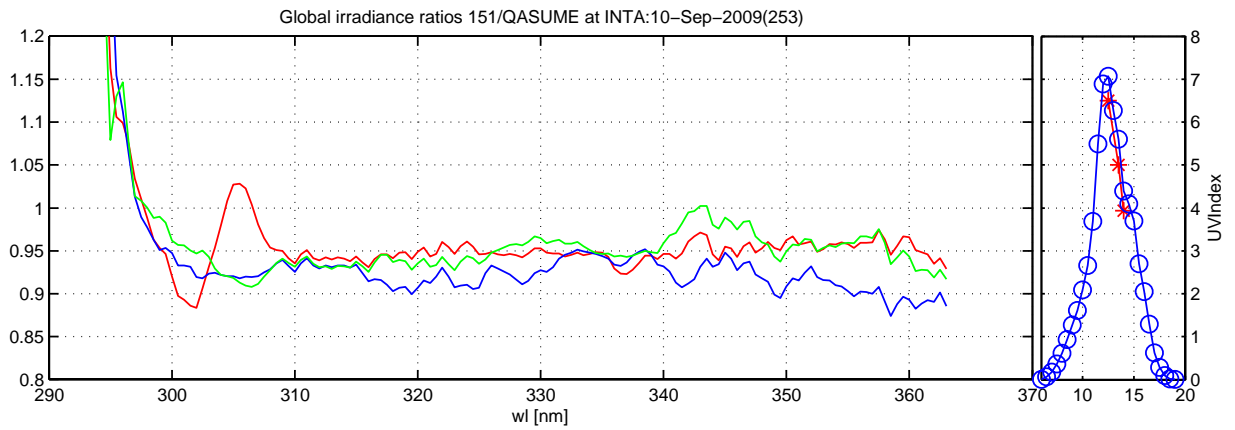
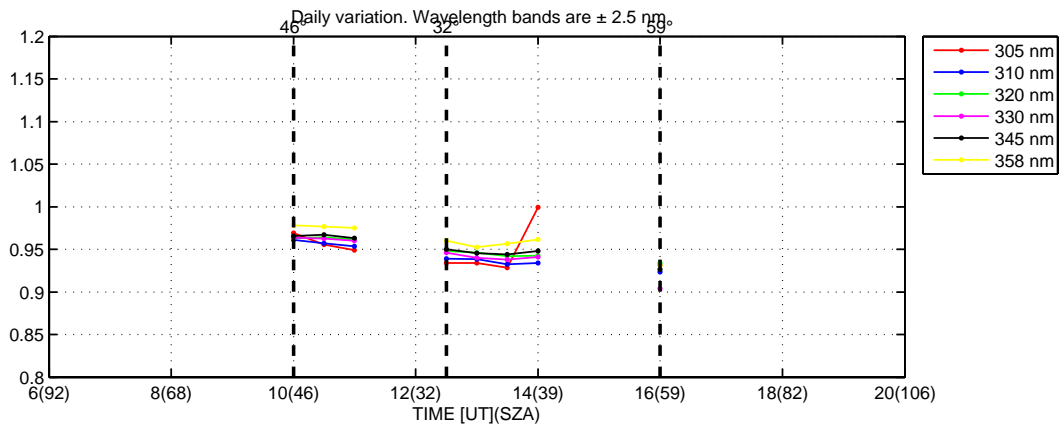
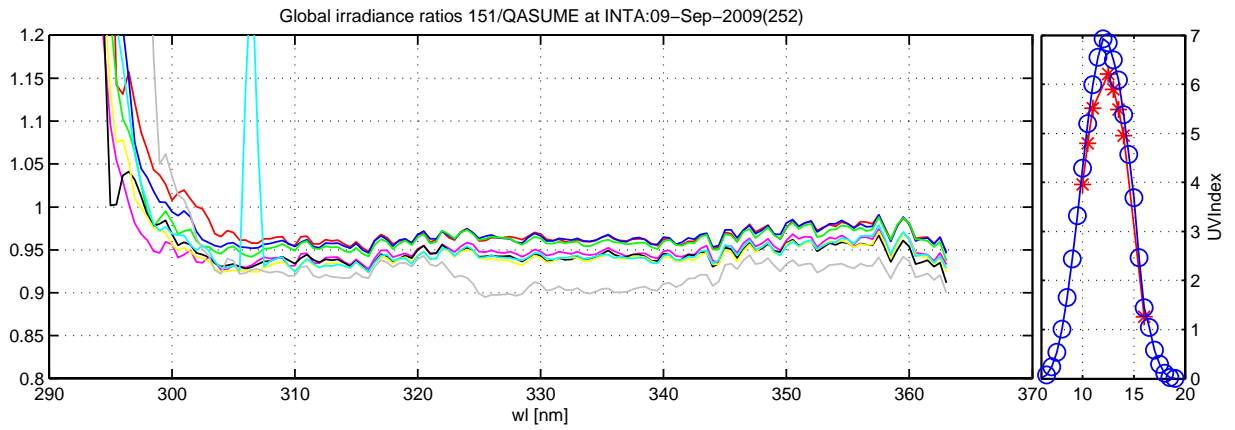

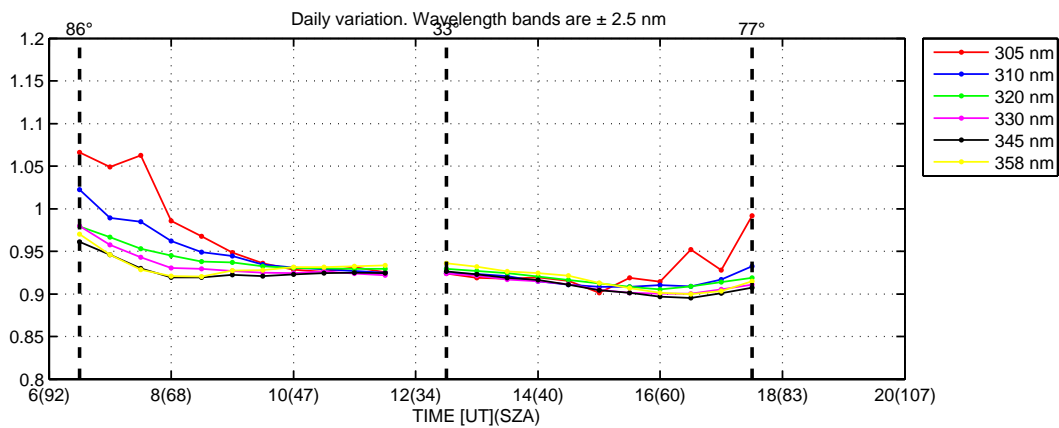
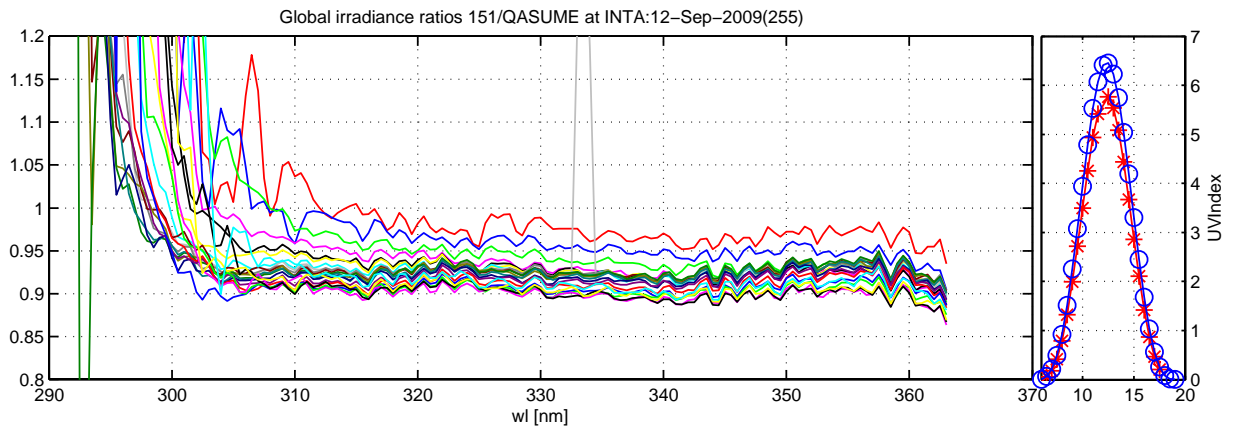
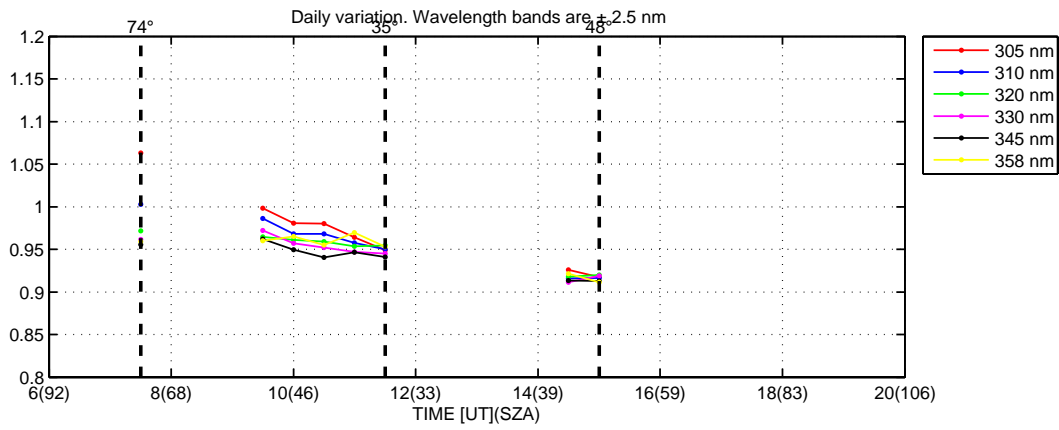
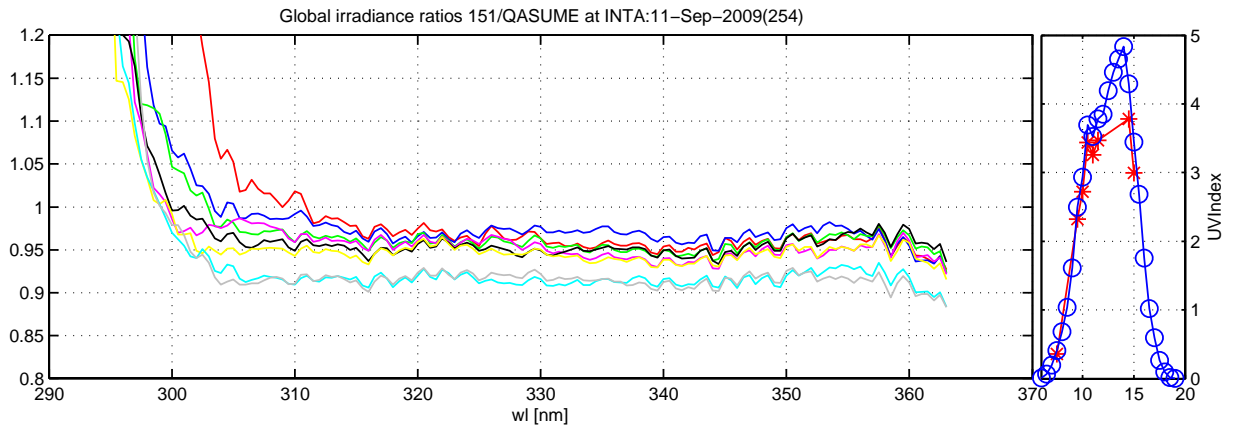



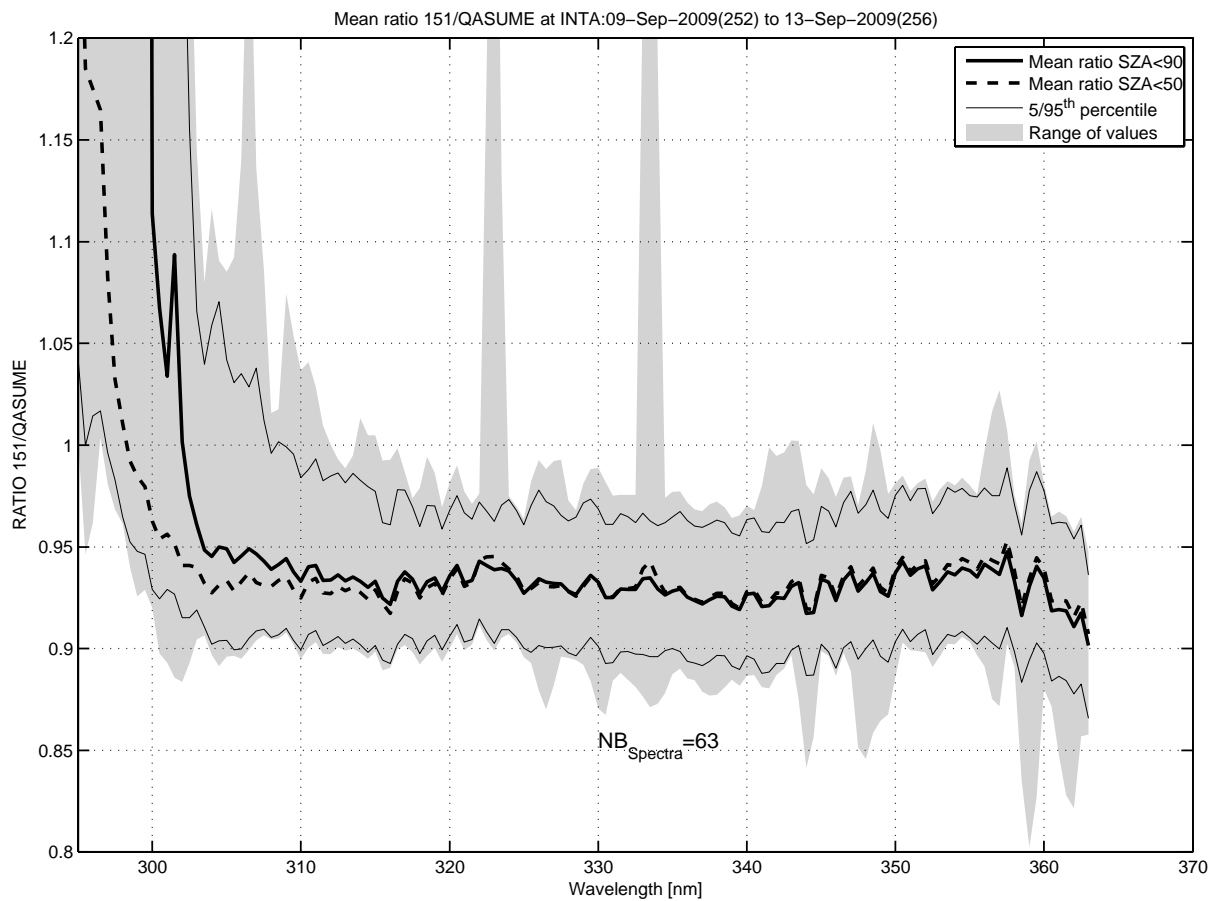
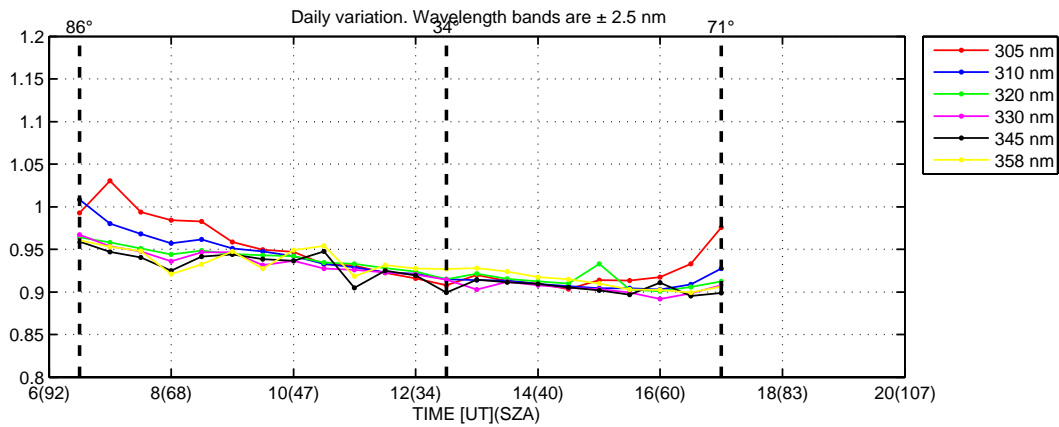
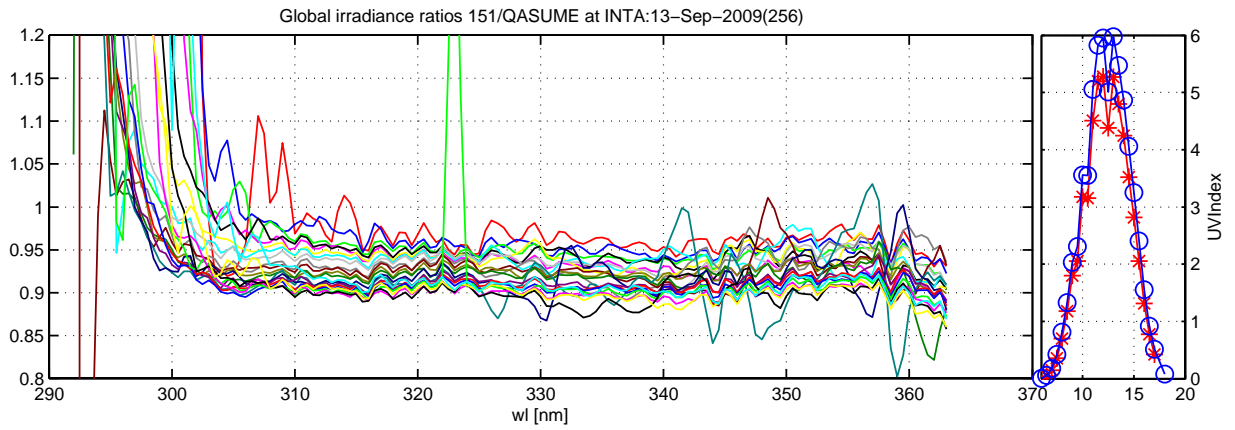

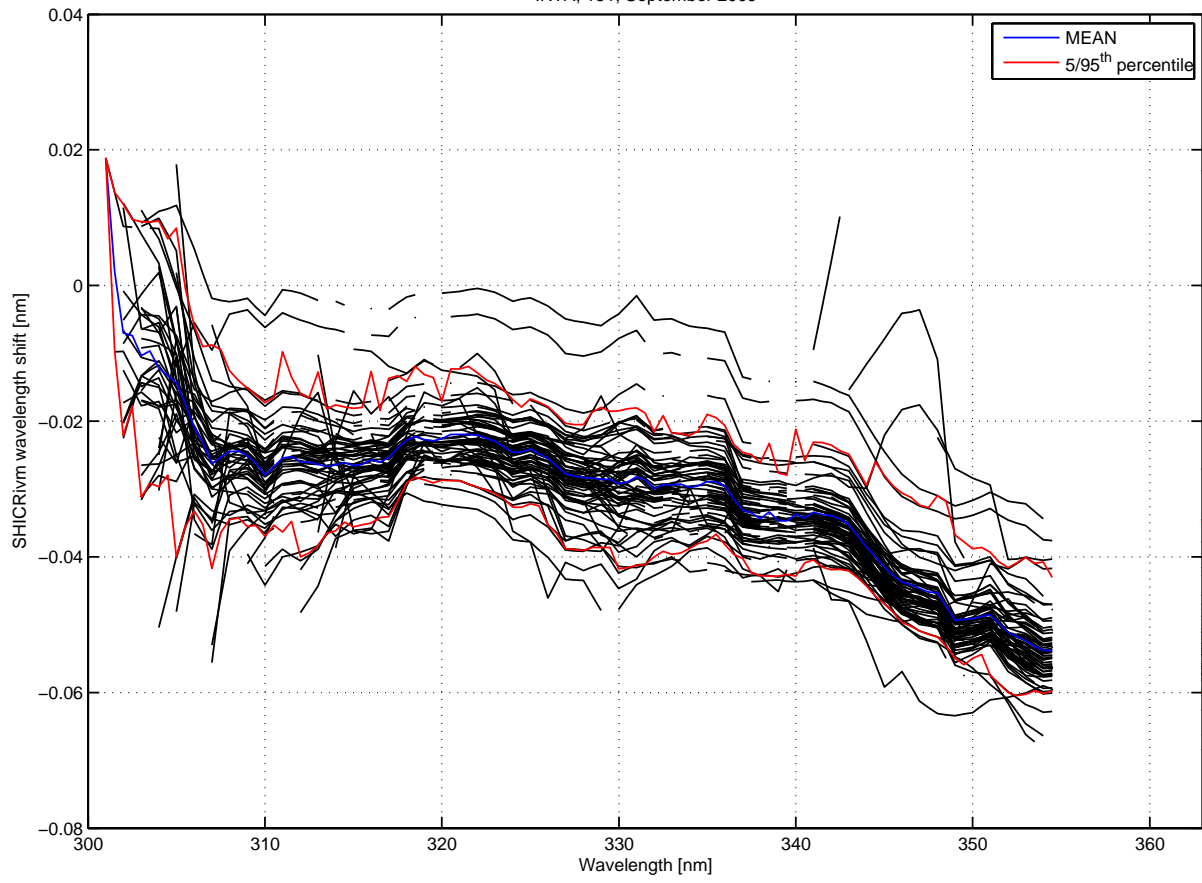

UV Index INTA, September 2009

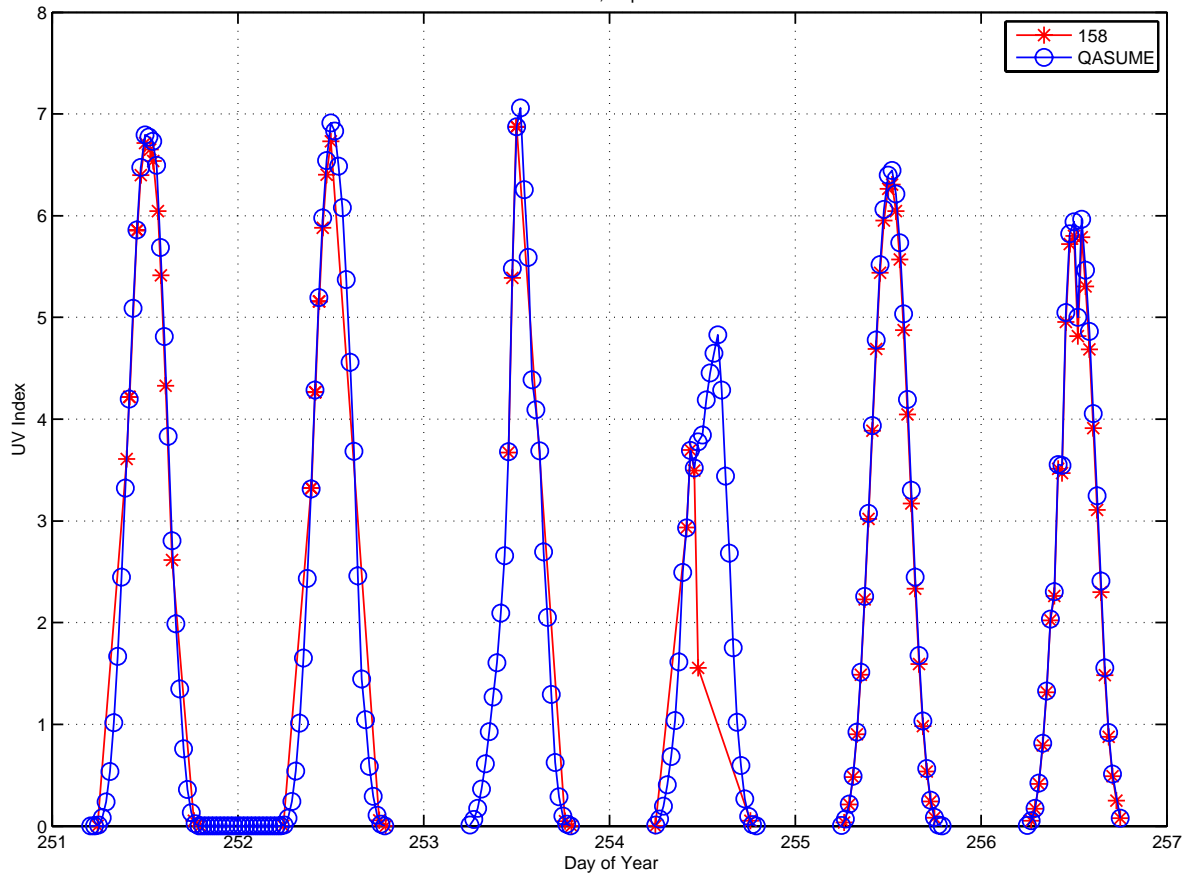

Global irradiance ratios 158/QASUME at INTA:08-Sep-2009(251) to 13-Sep-2009(256)

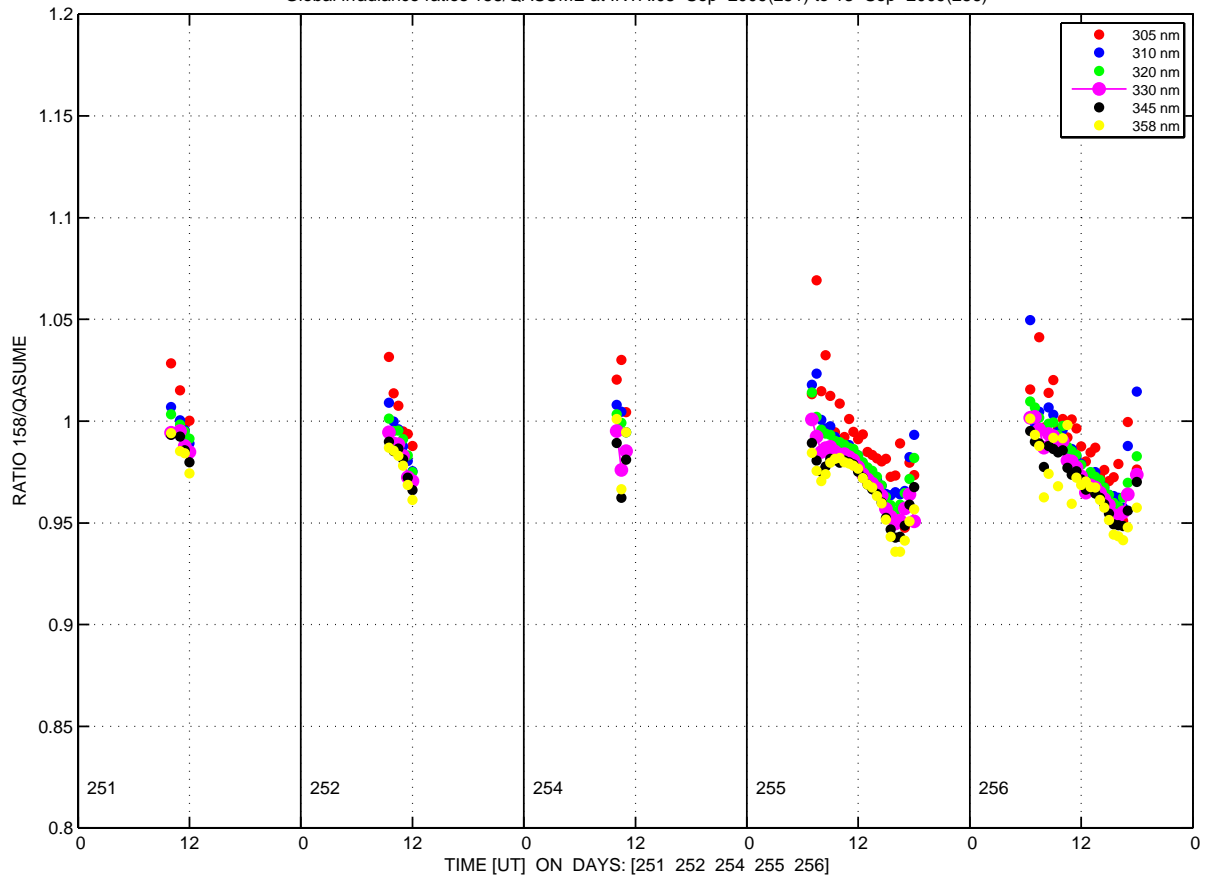

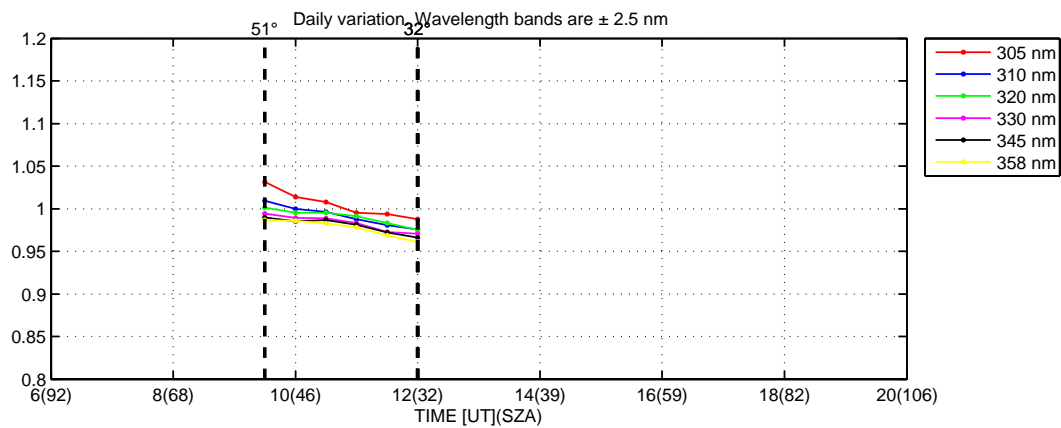
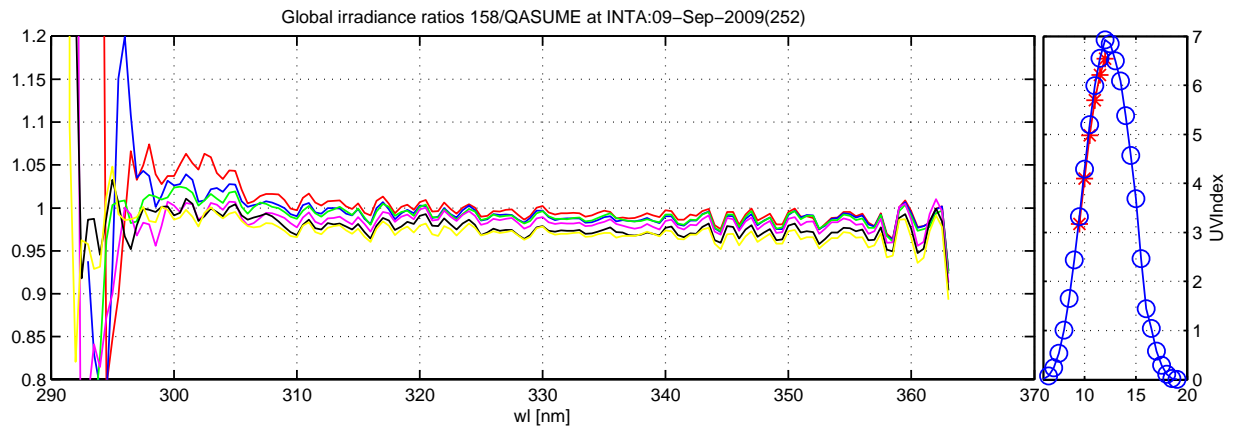
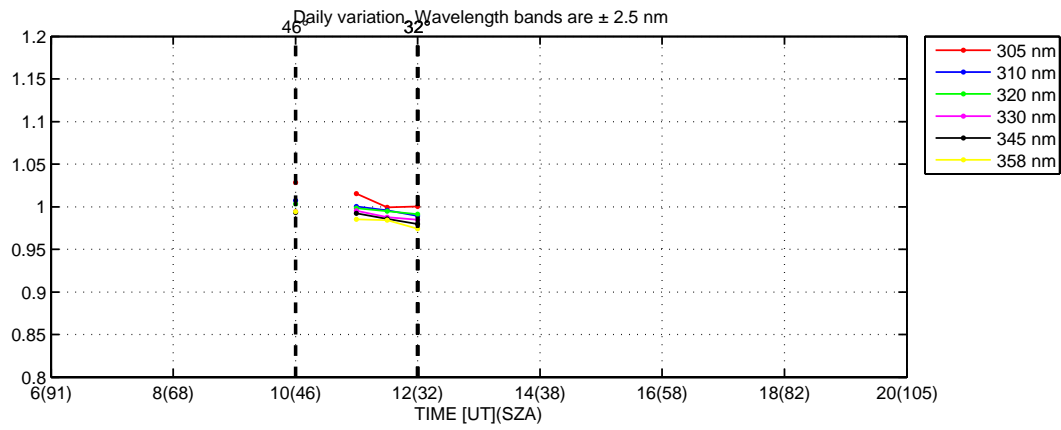
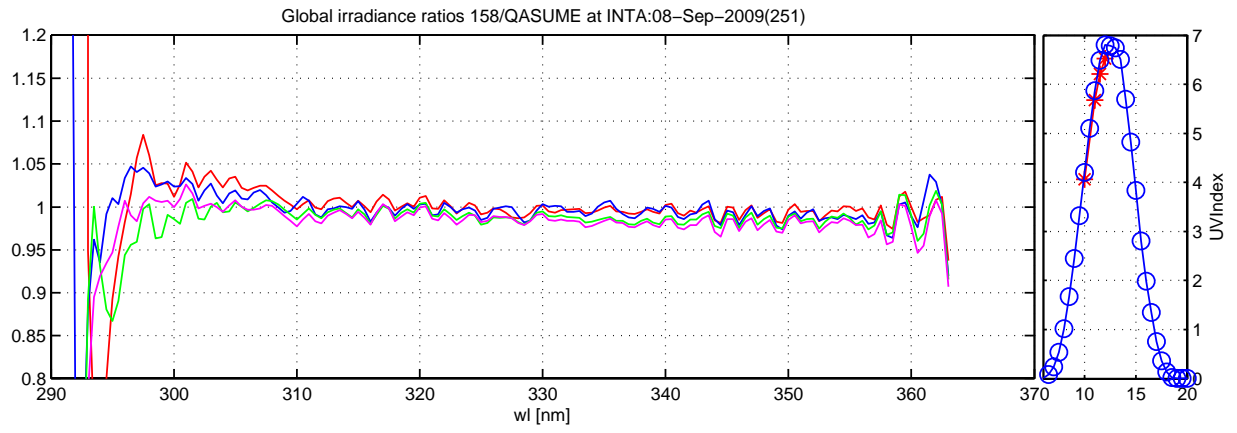

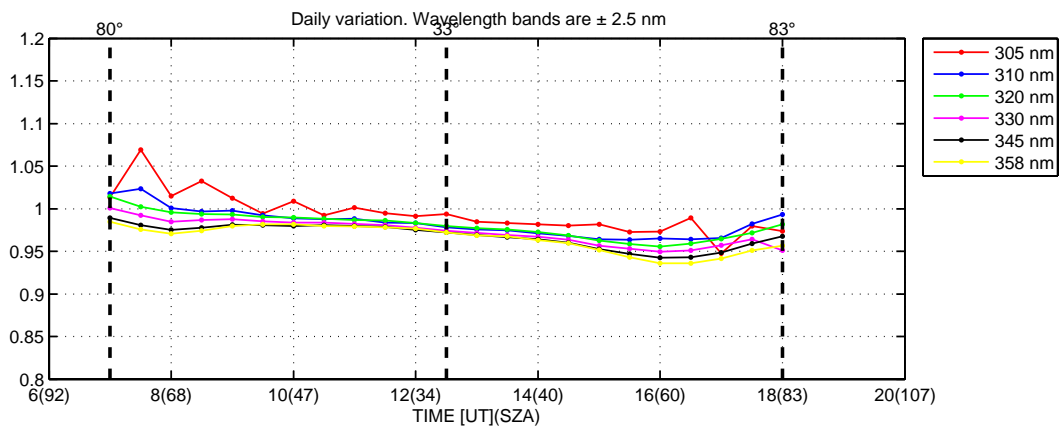
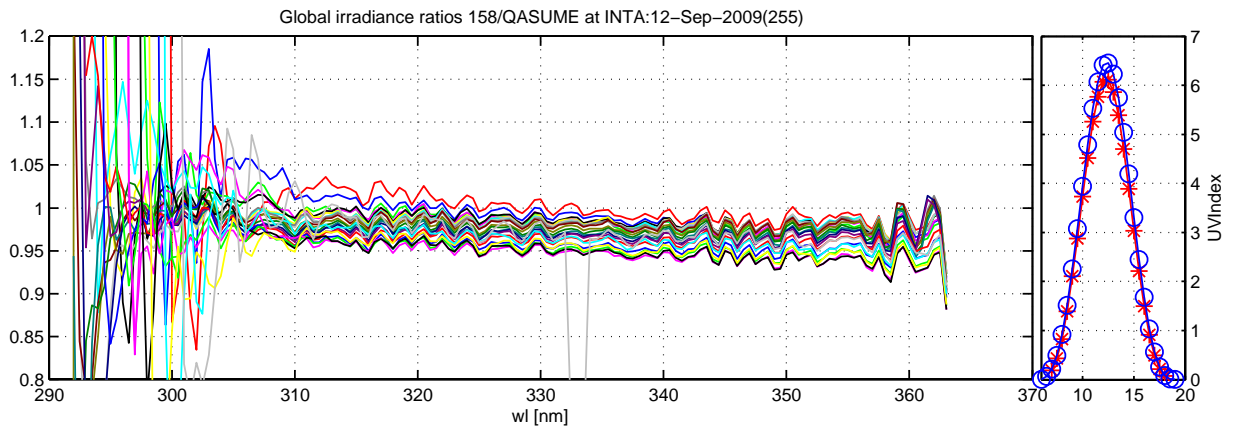
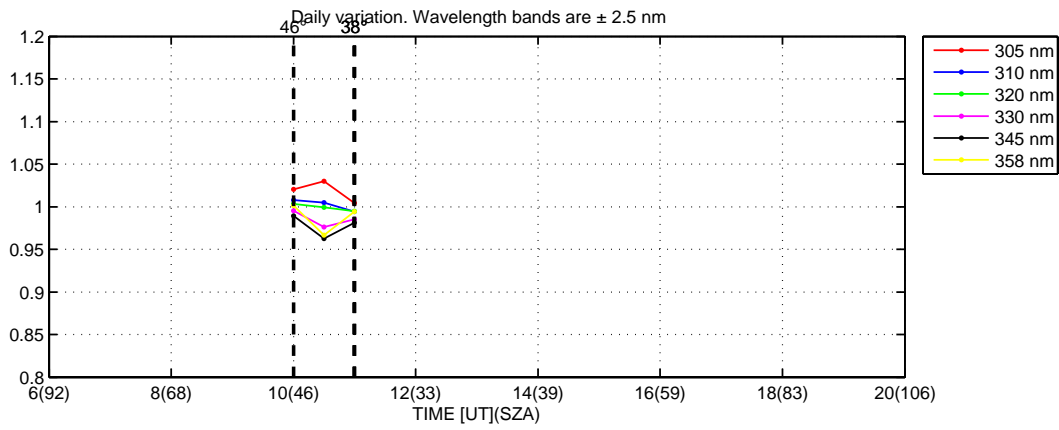
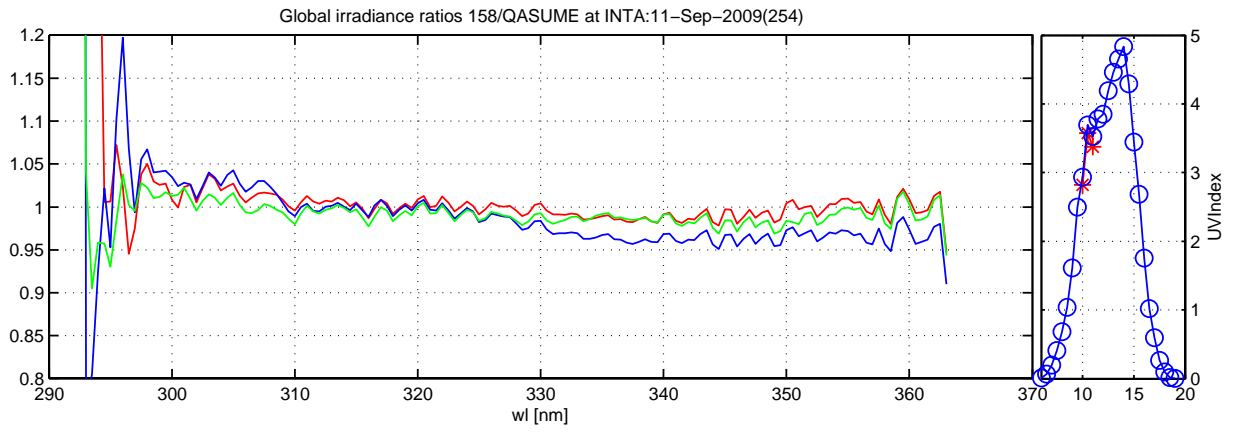

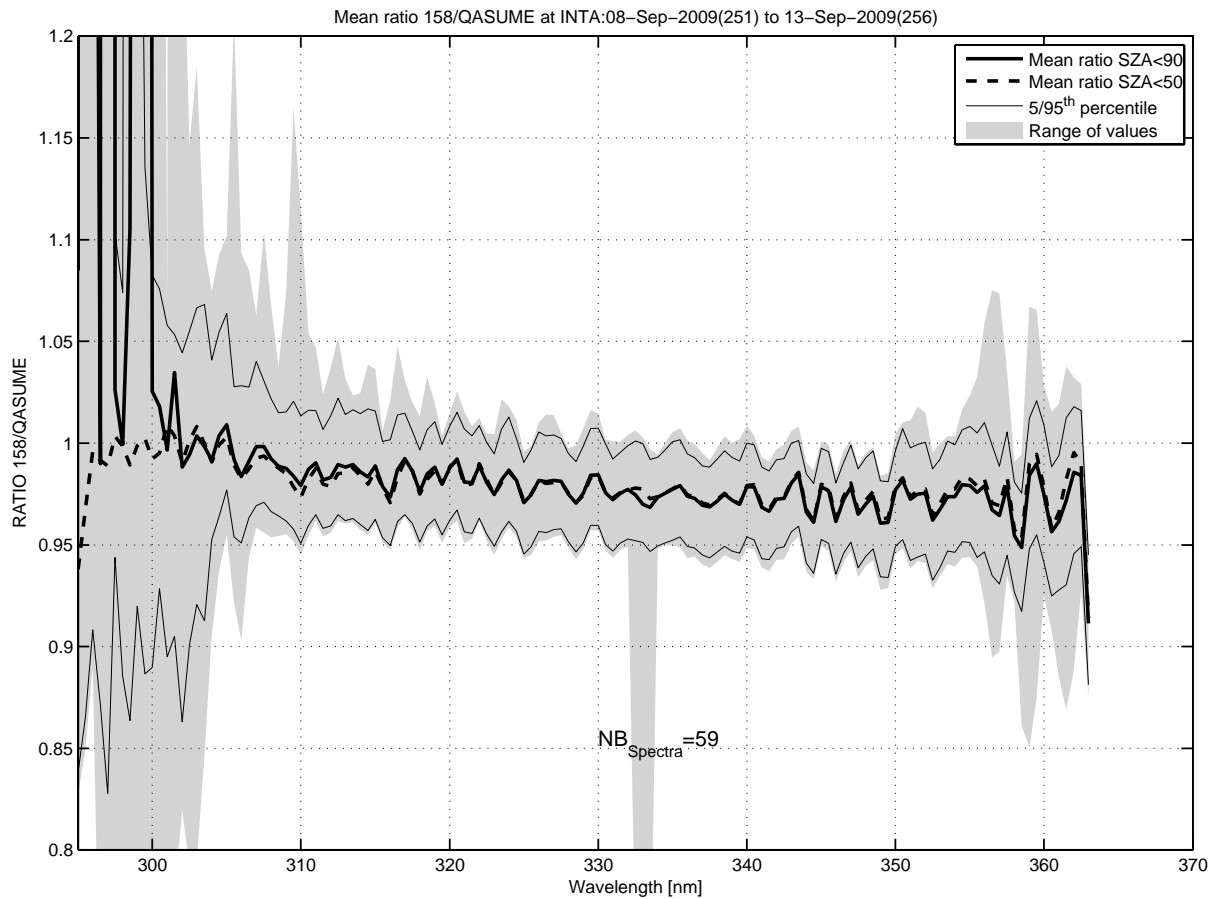
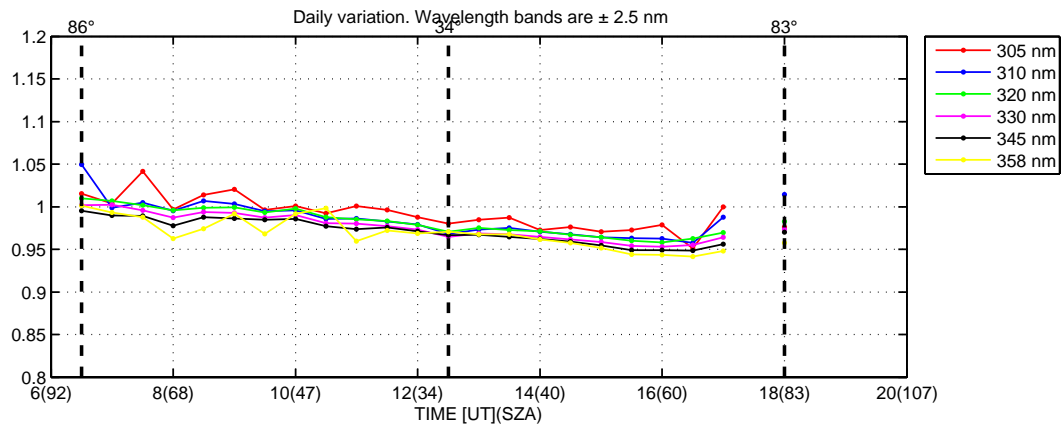
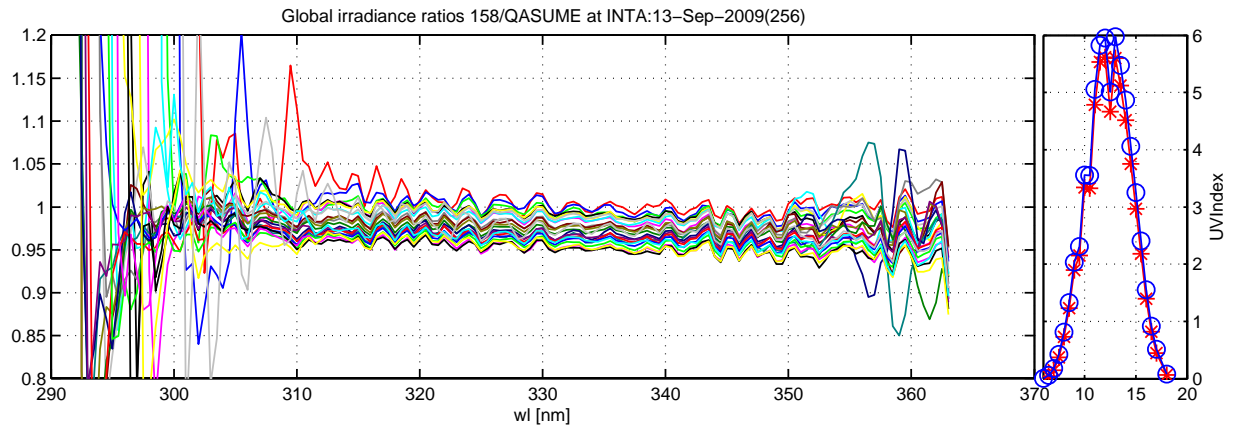

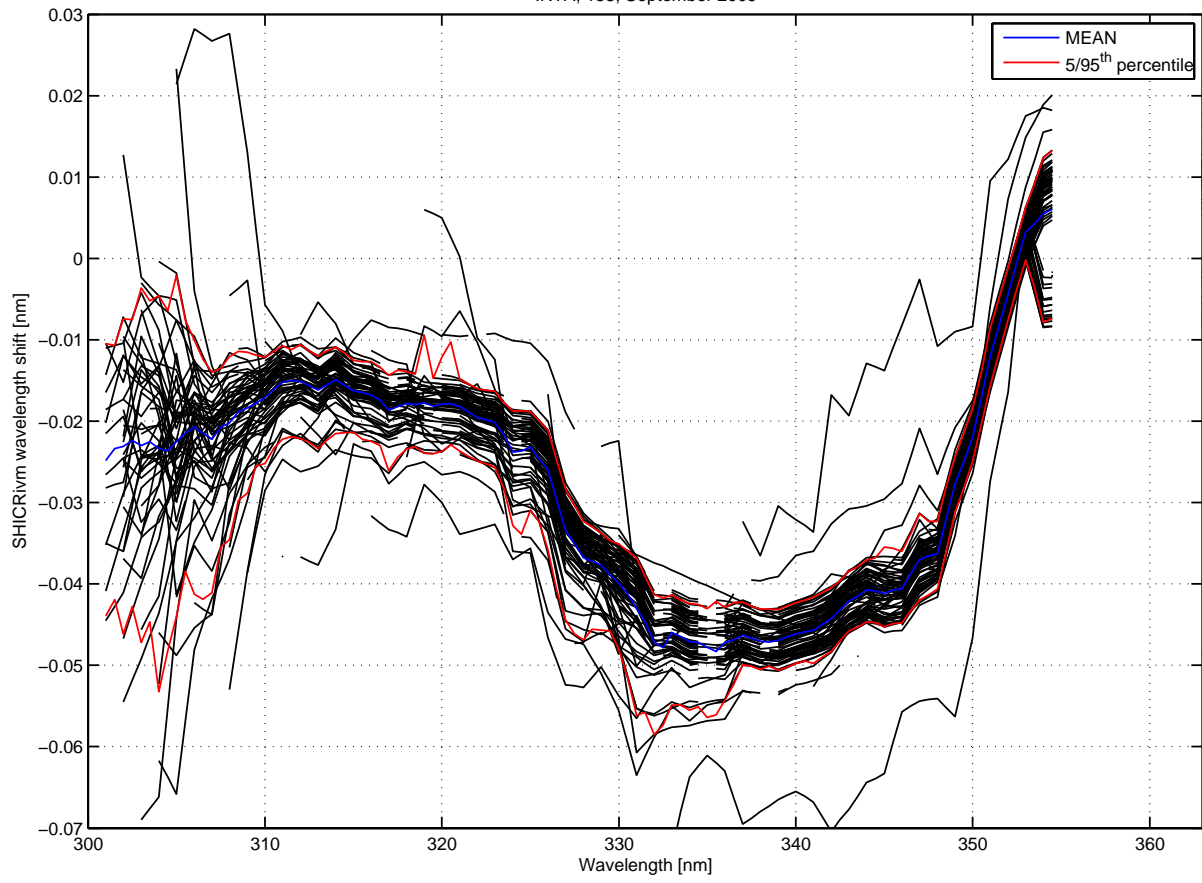

UV Index INTA, September 2009

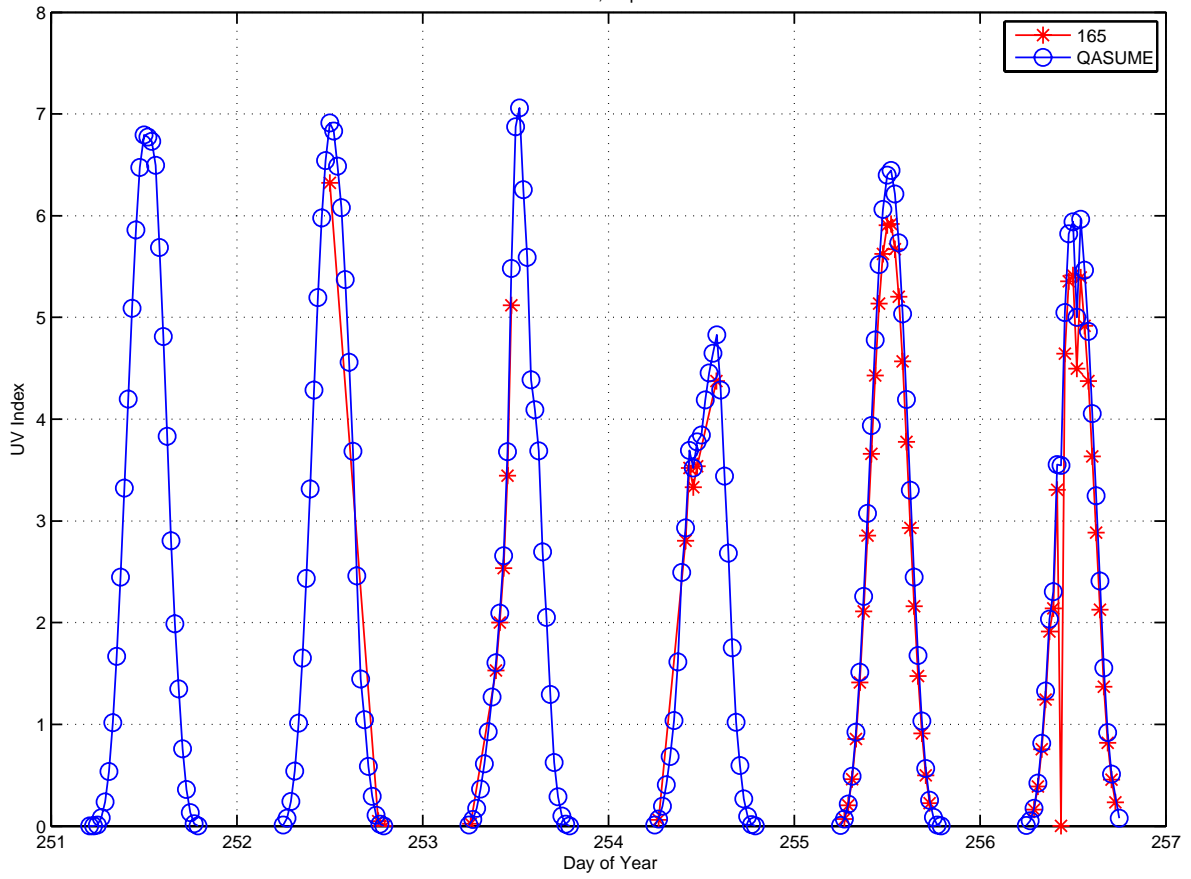

Global irradiance ratios 165/QASUME at INTA:10-Sep-2009(253) to 13-Sep-2009(256)

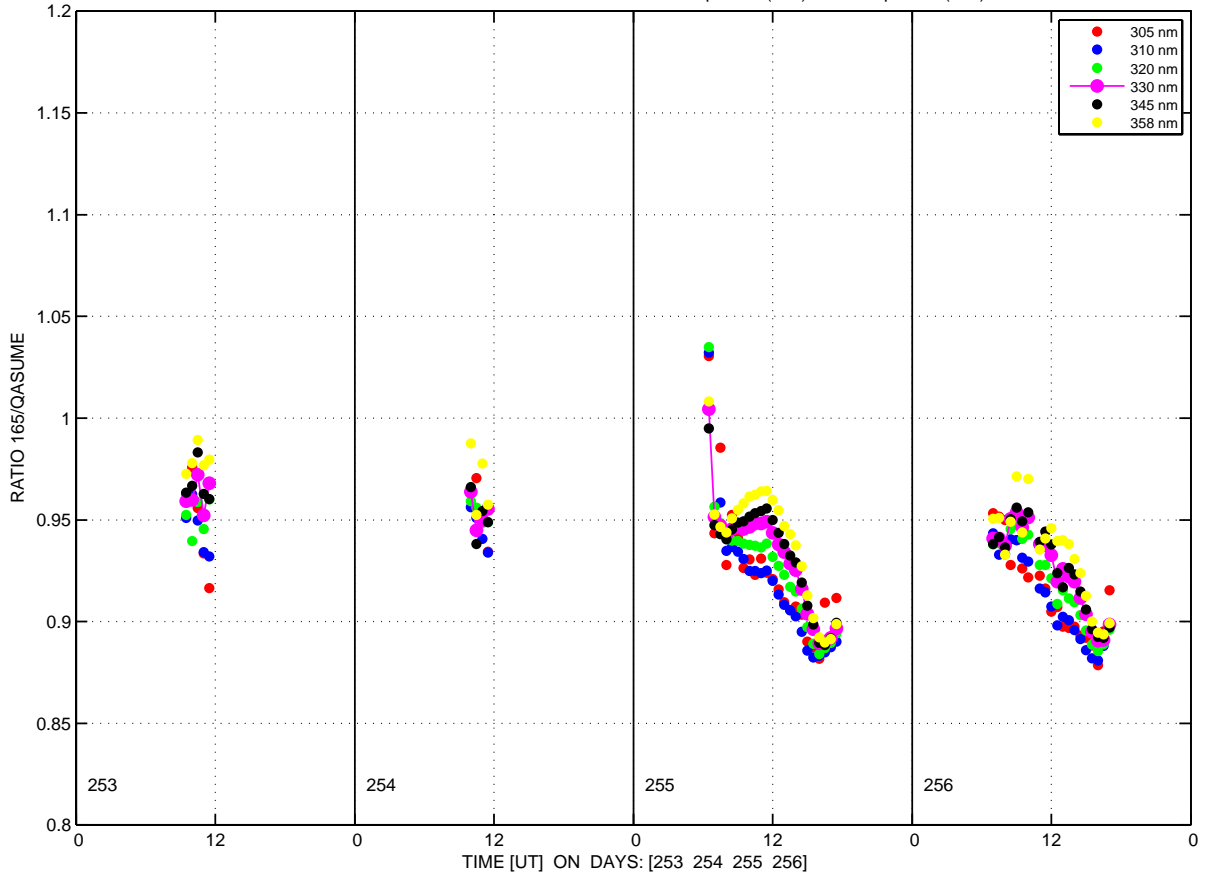



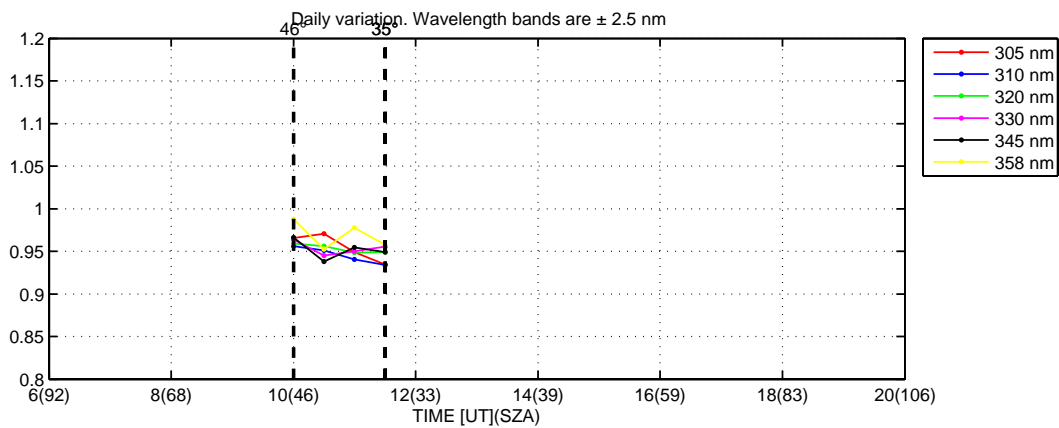
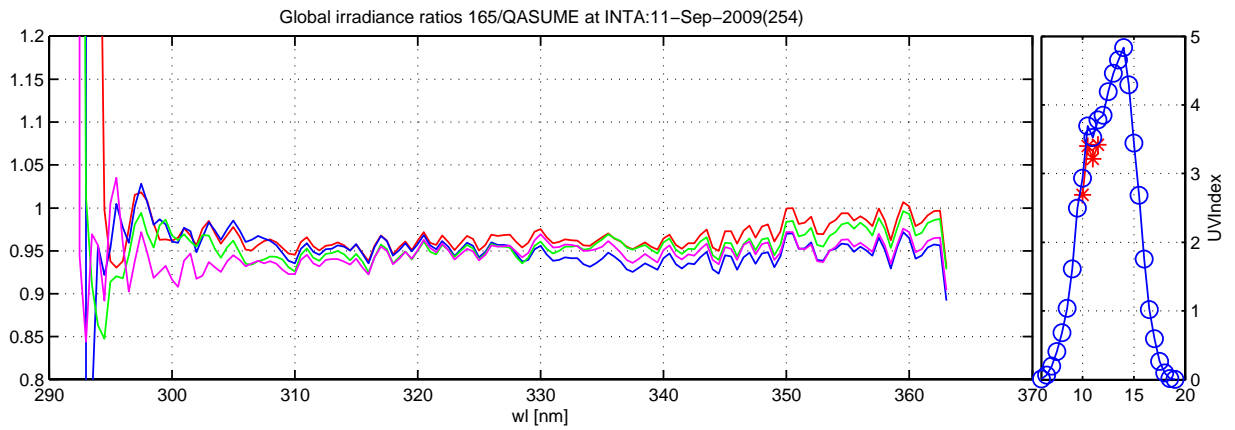
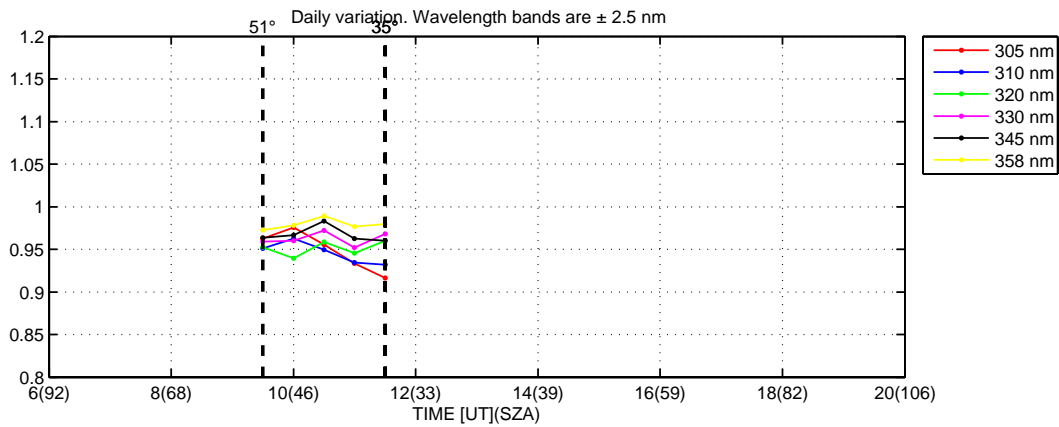
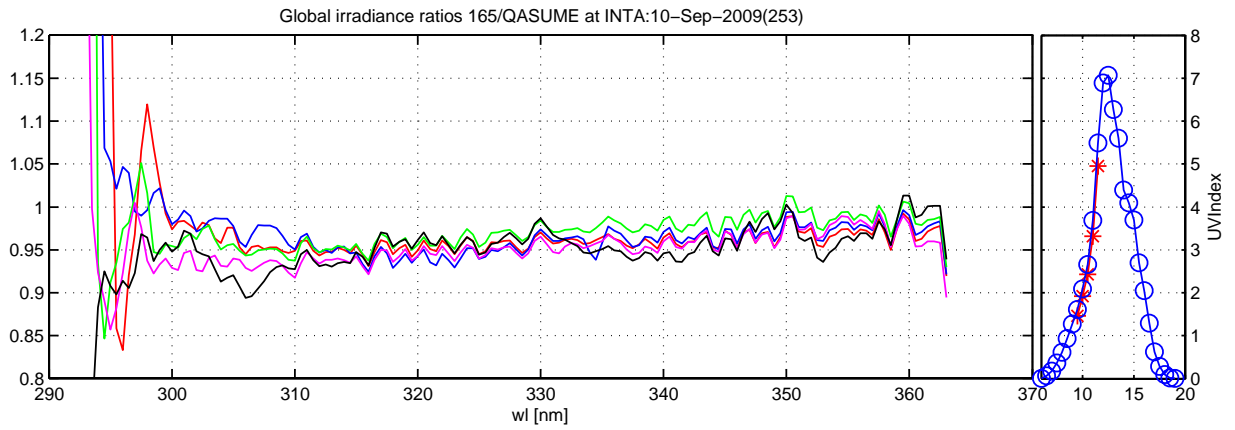

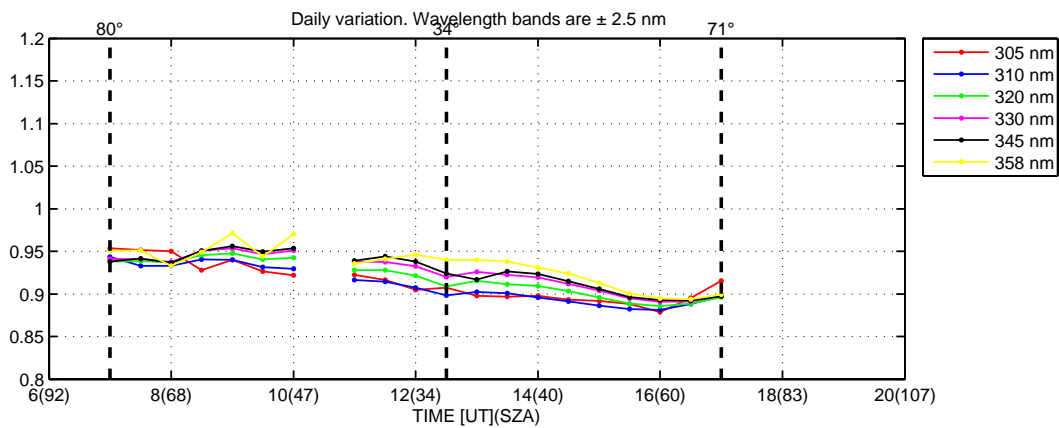
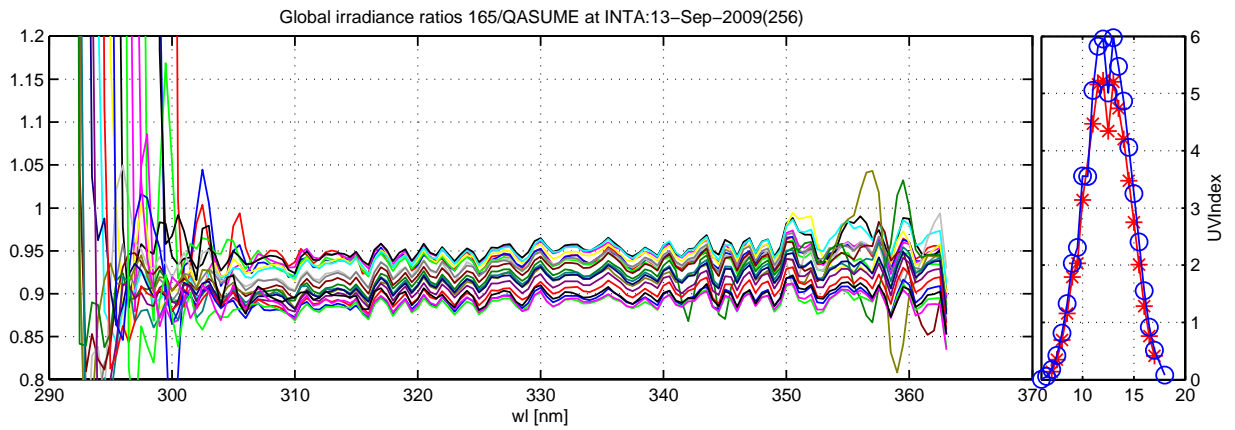
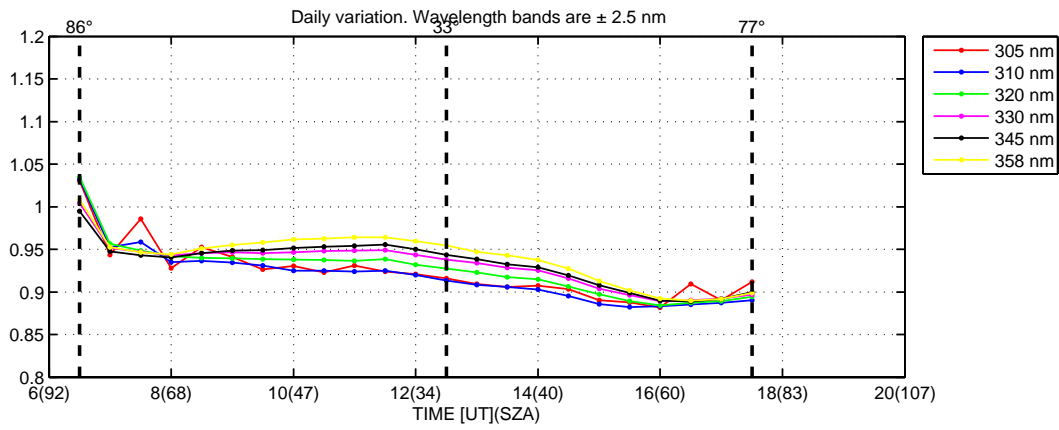
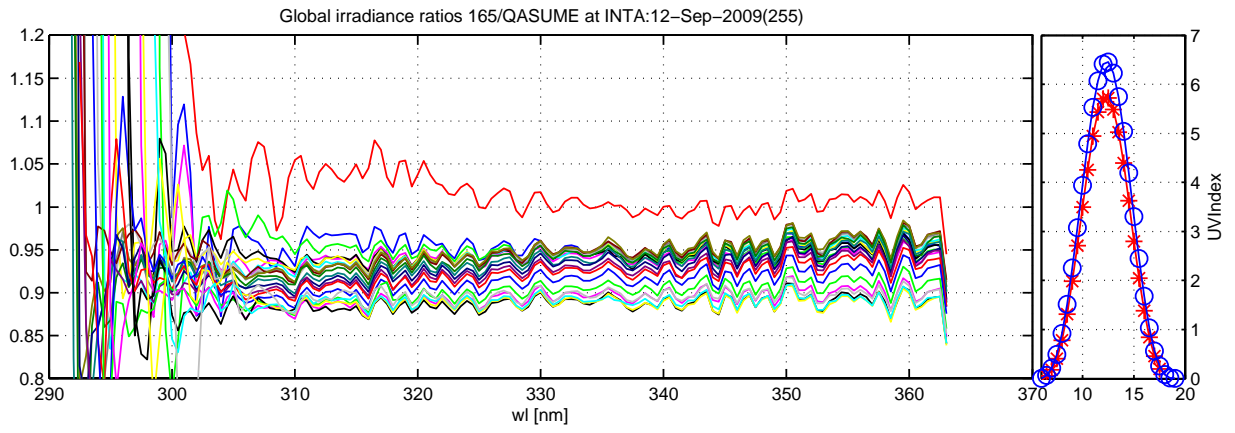

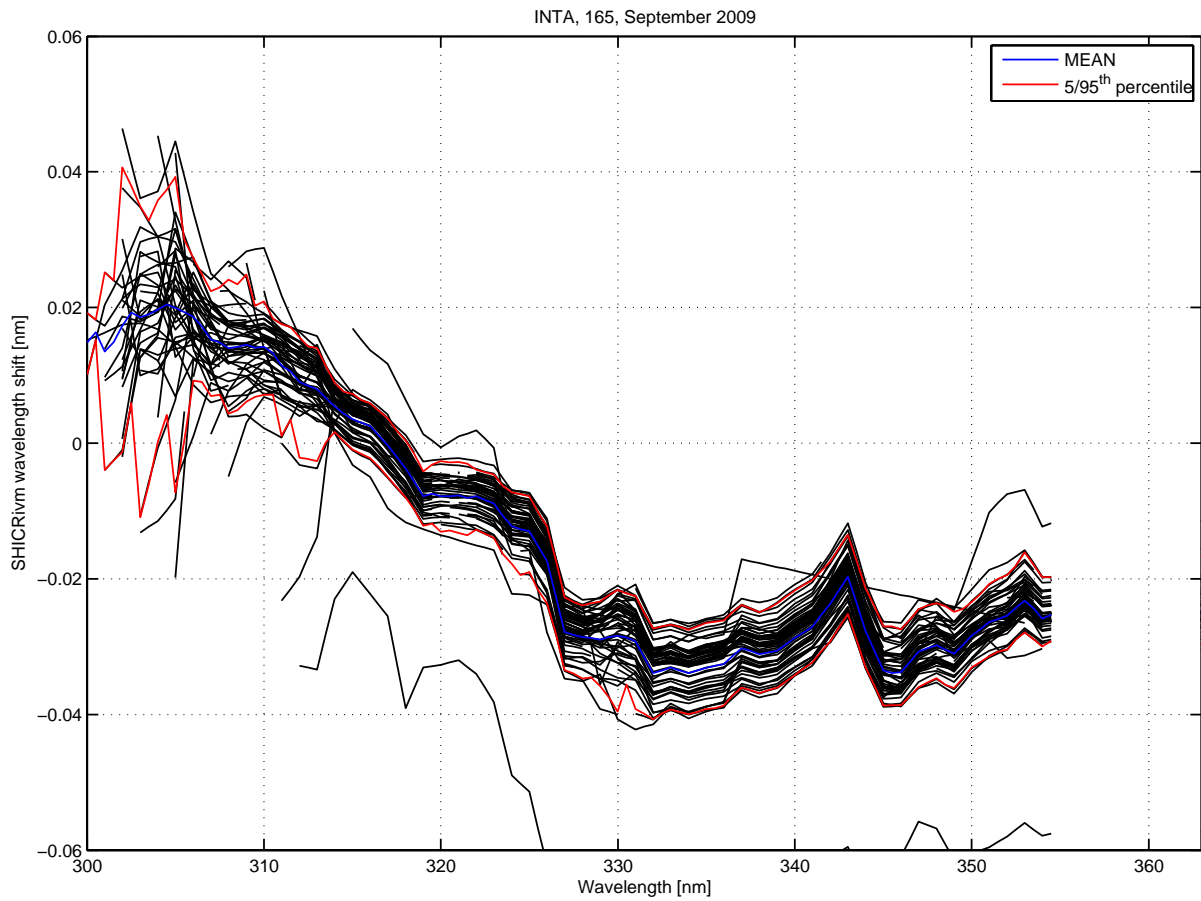
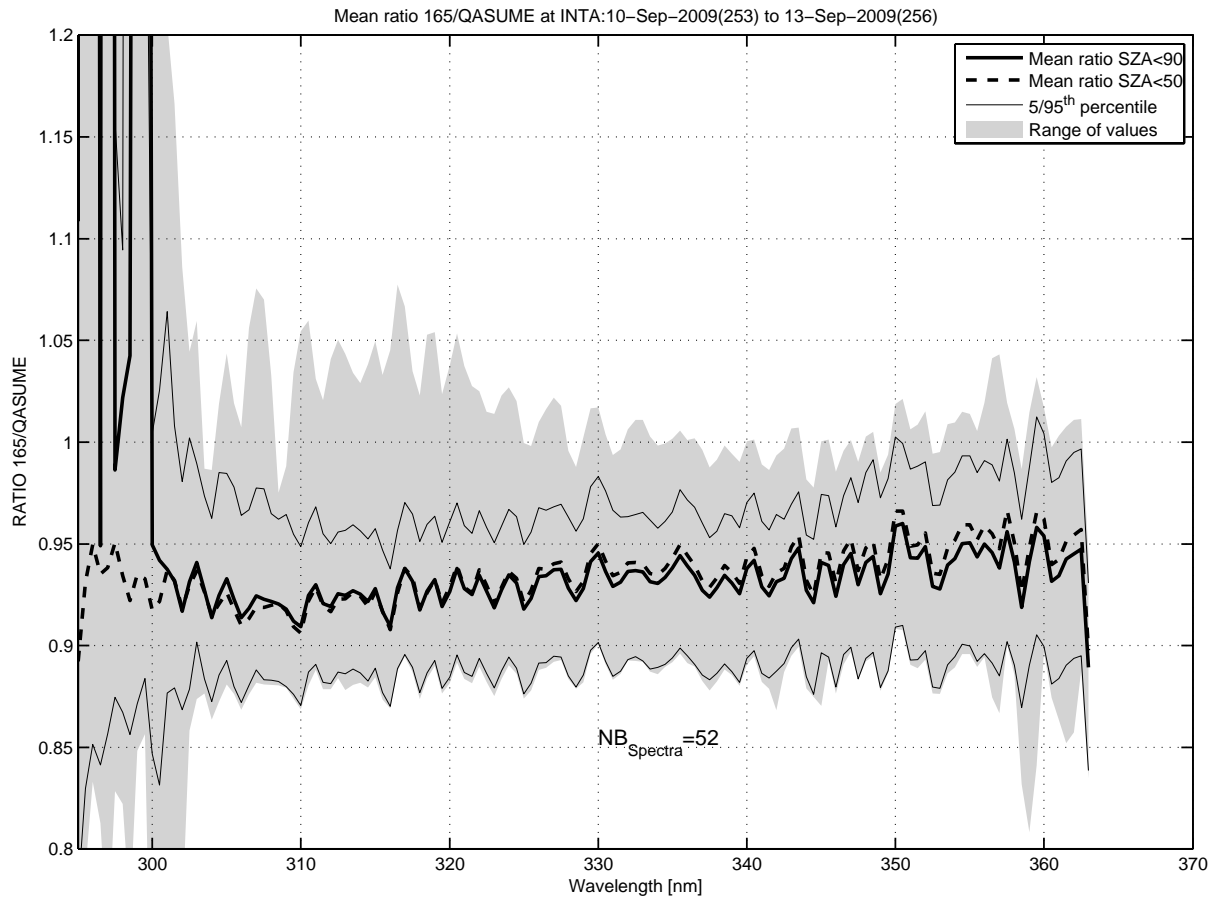

UV Index INTA, September 2009

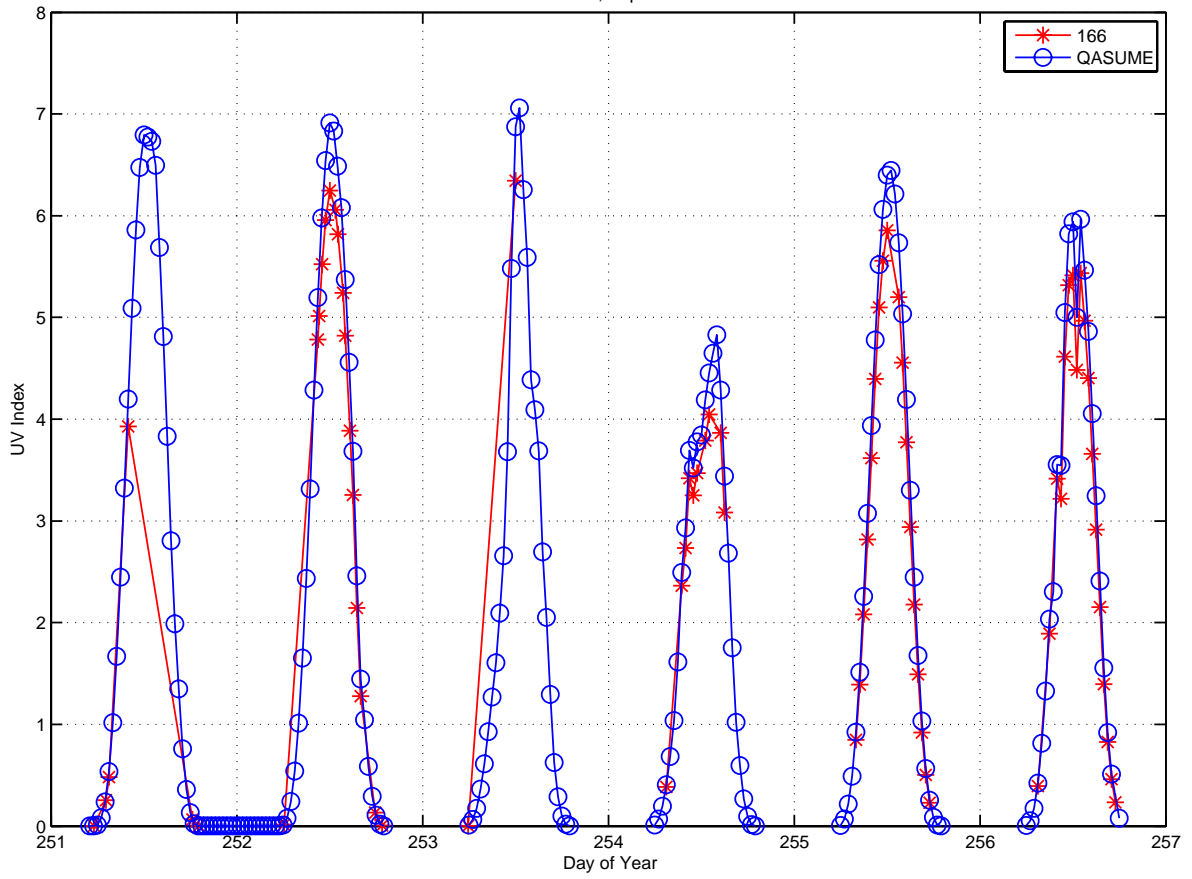

Global irradiance ratios 166/QASUME at INTA:08-Sep-2009(251) to 13-Sep-2009(256)

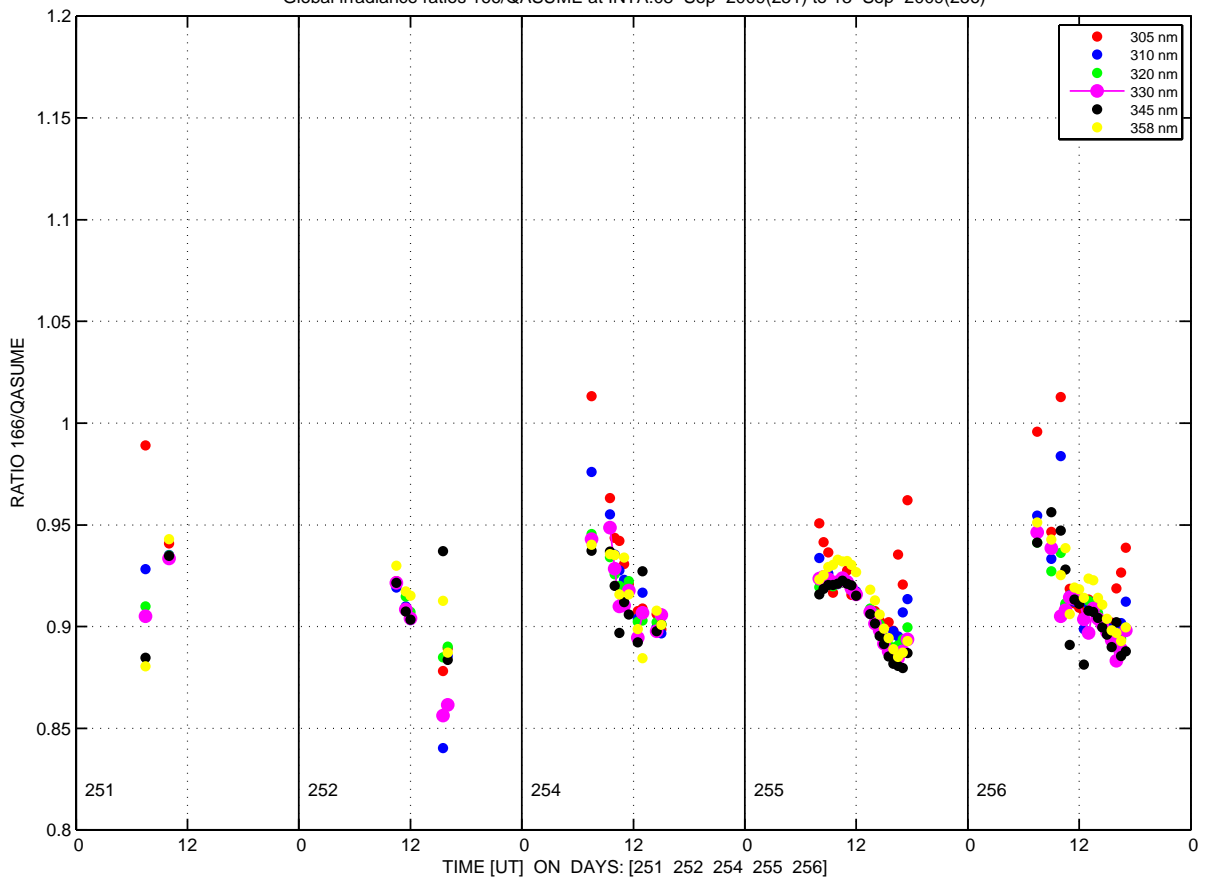

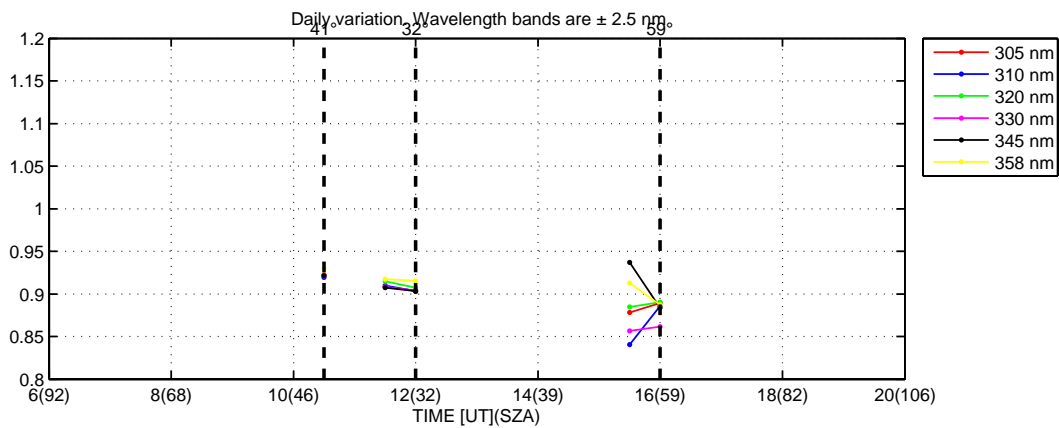
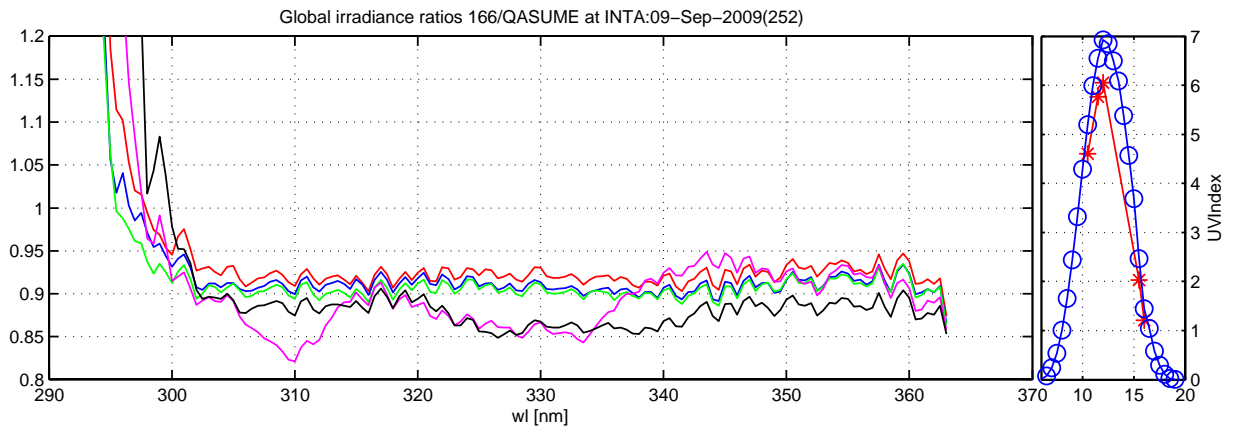
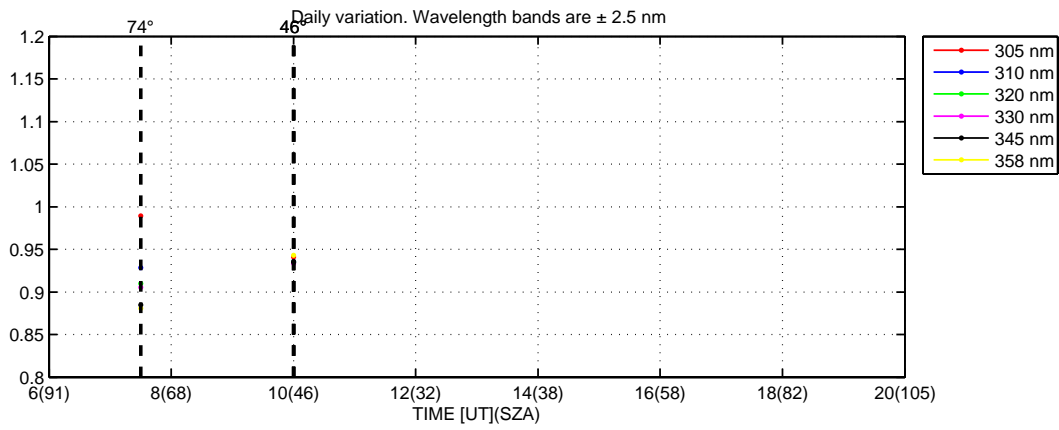
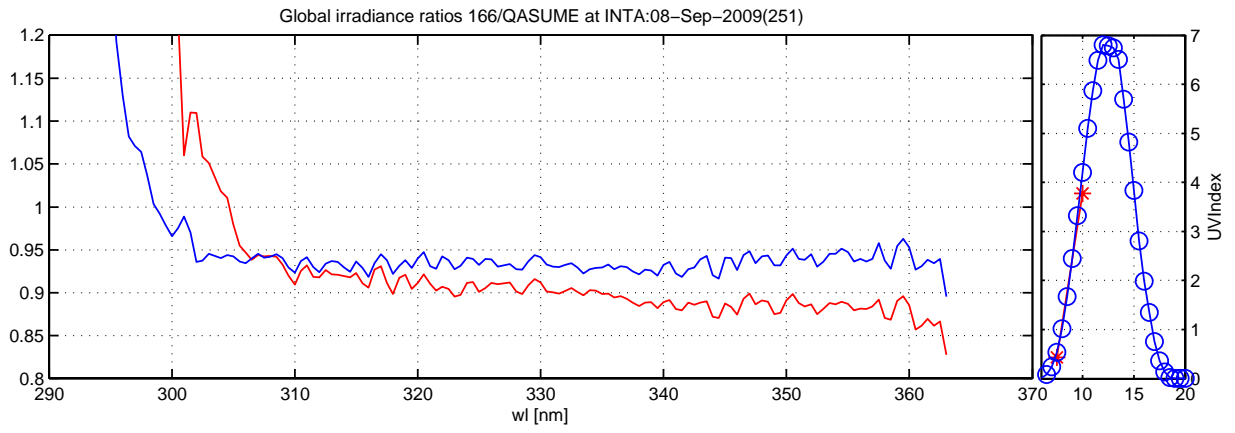

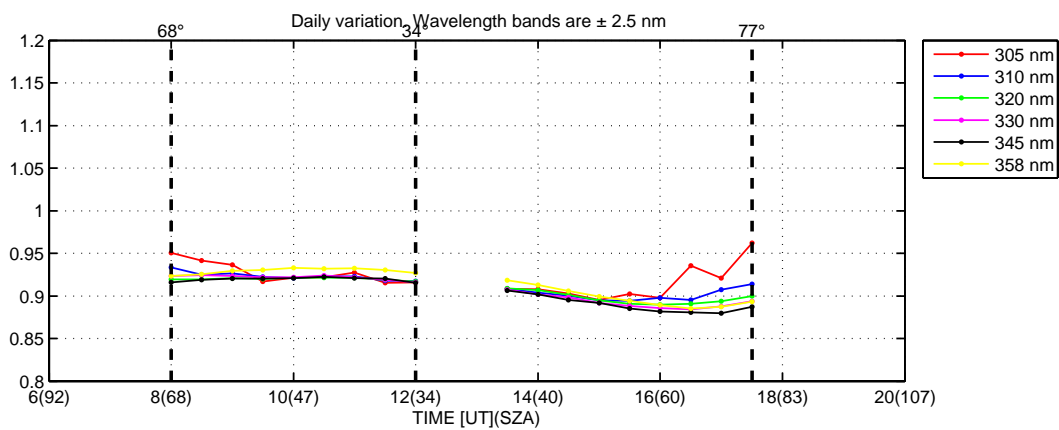
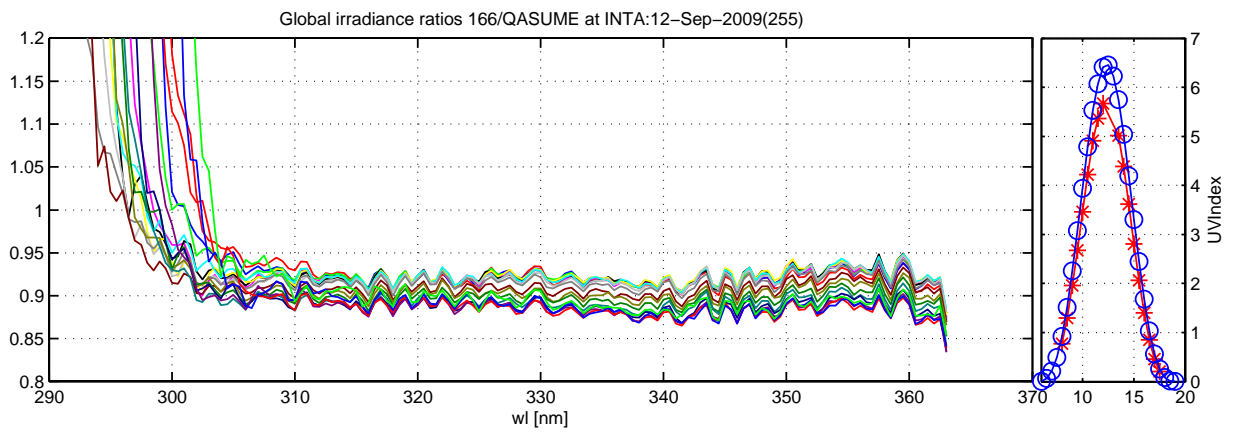
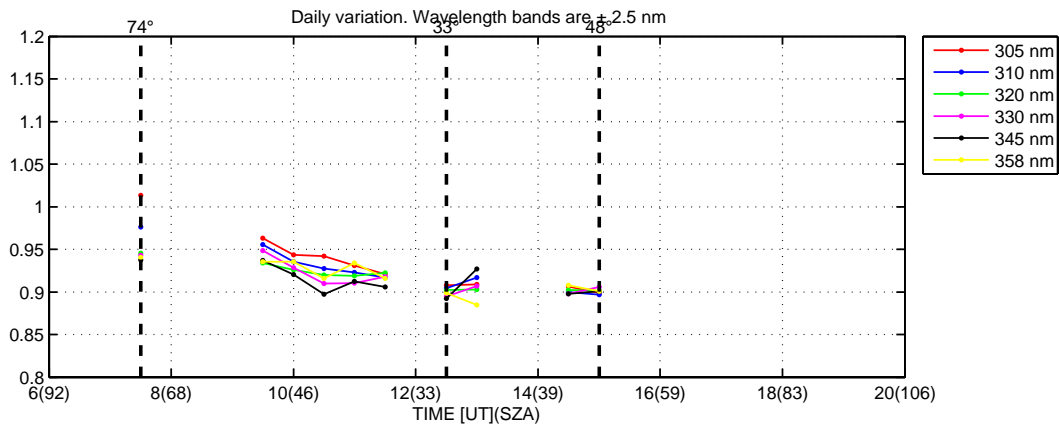
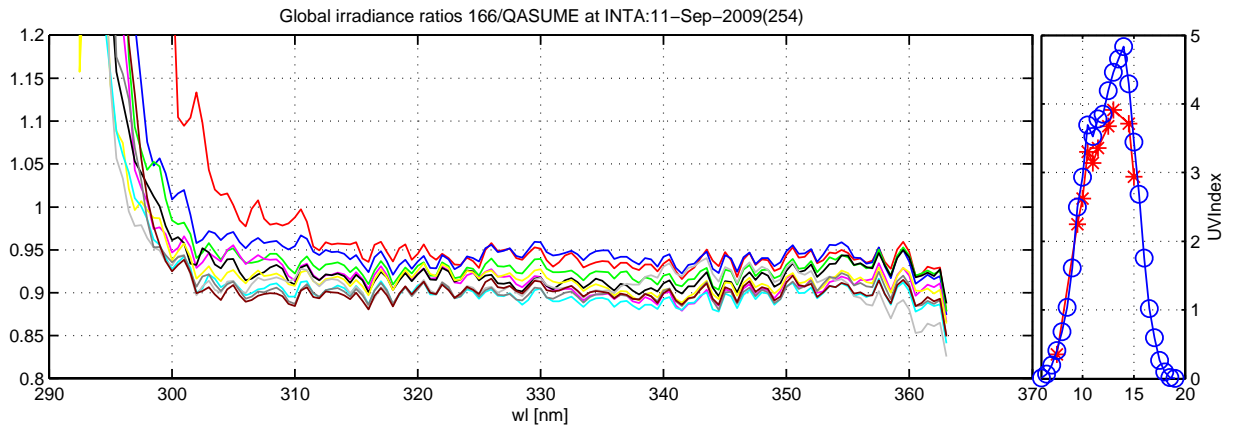

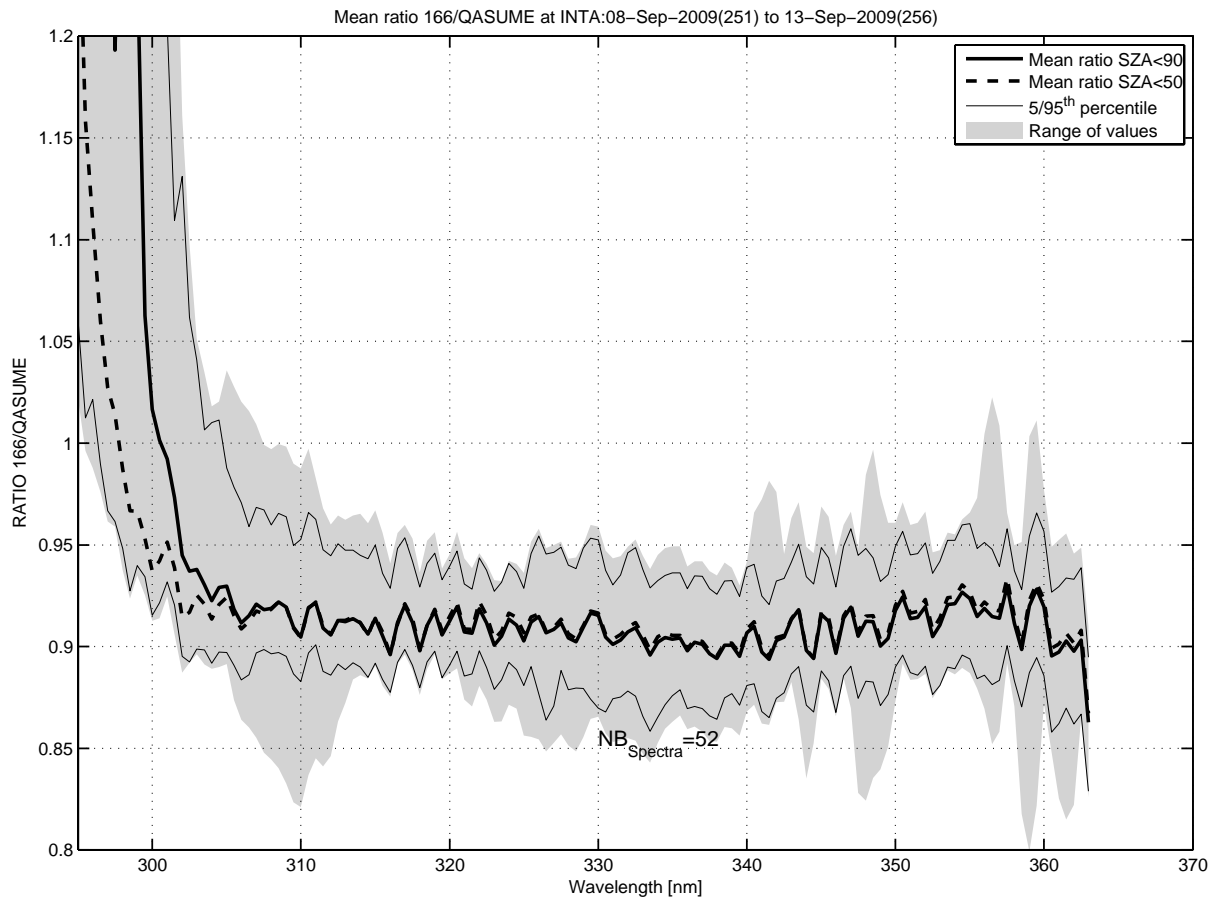
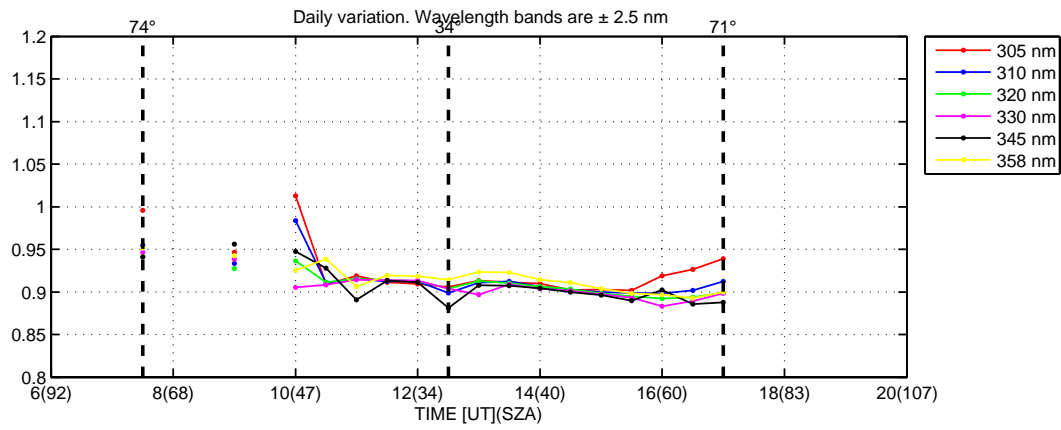
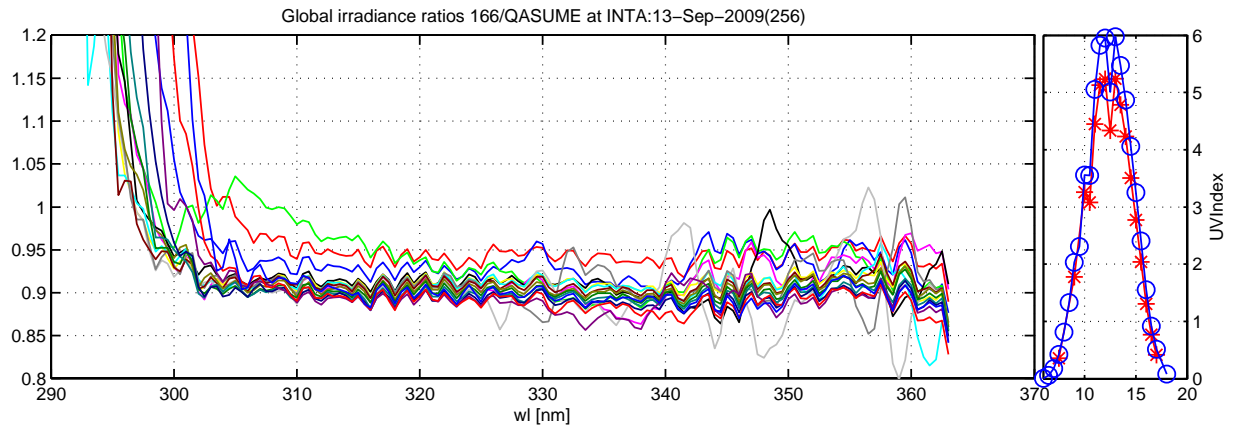

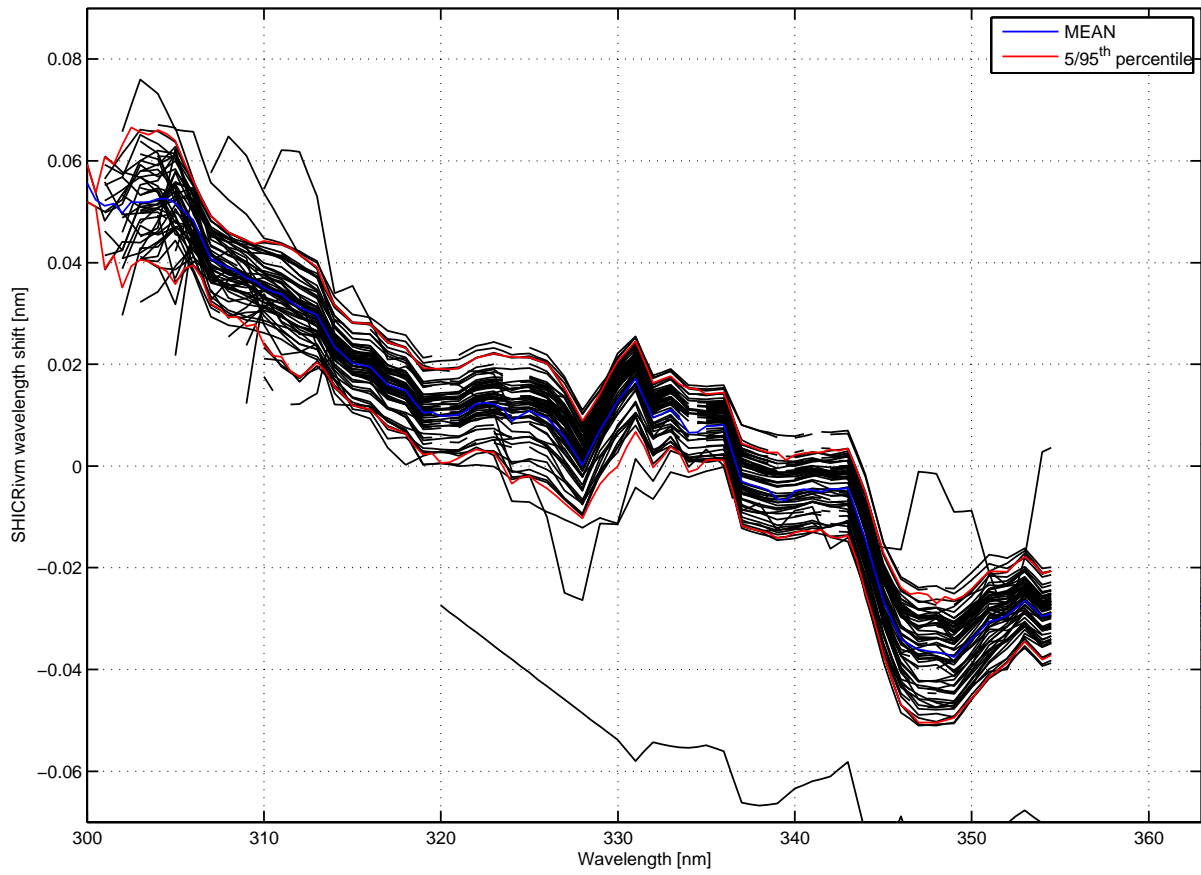



UV Index INTA, September 2009

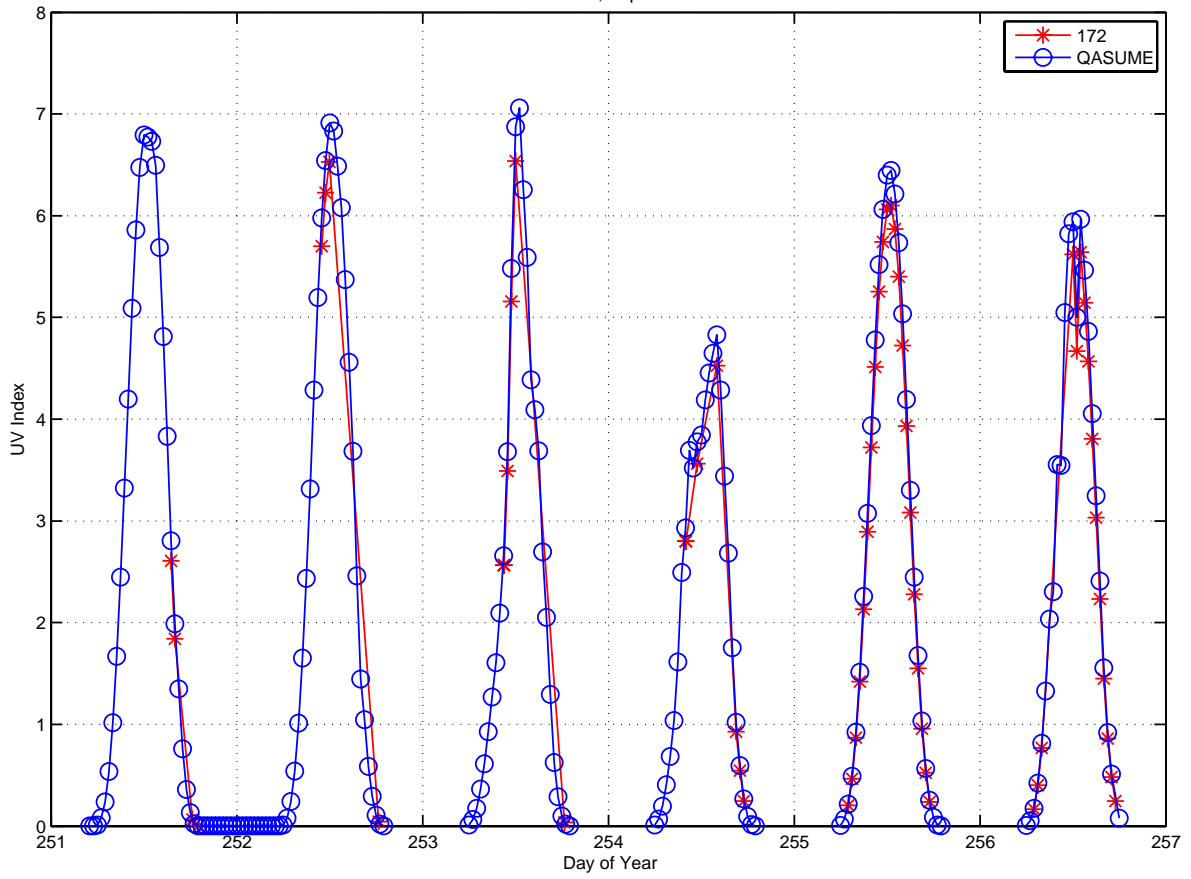

Global irradiance ratios 172/QASUME at INTA:08-Sep-2009(251) to 13-Sep-2009(256)

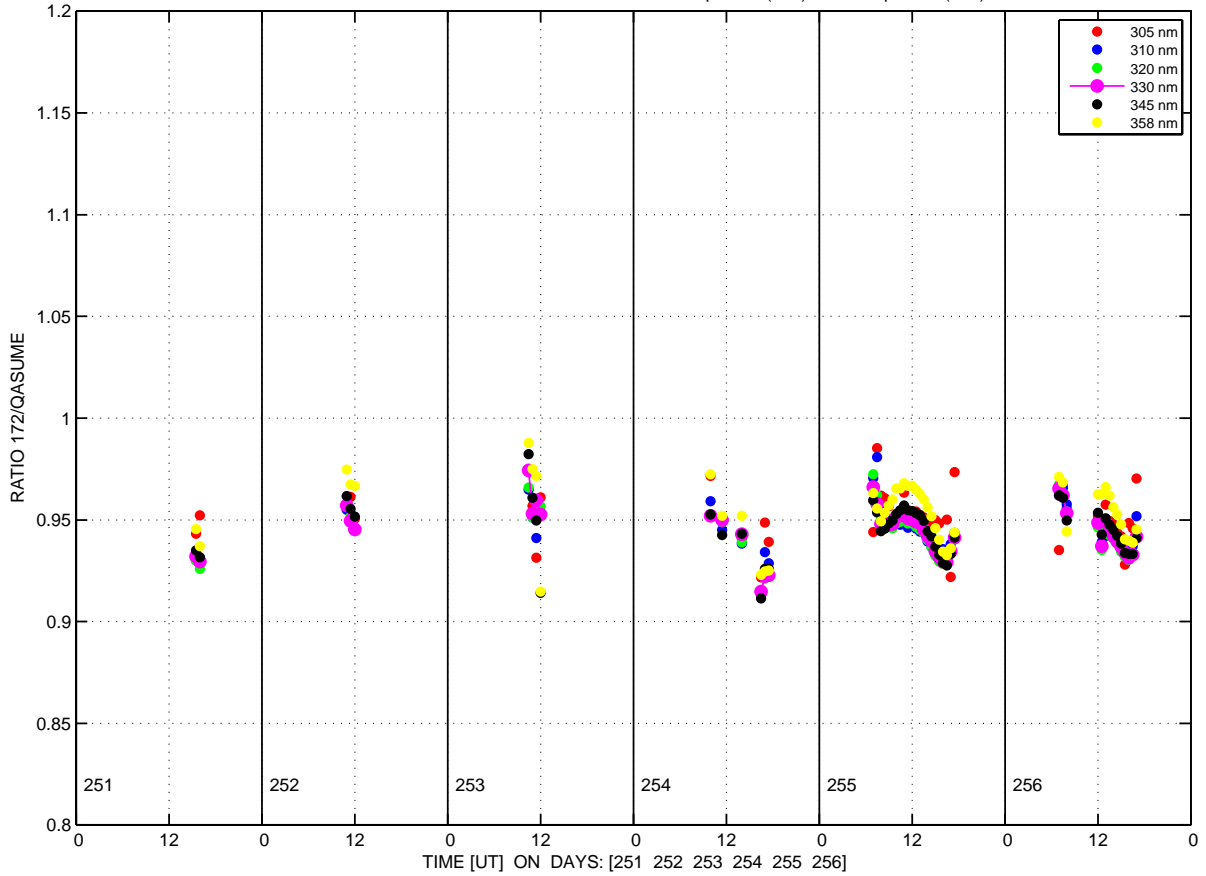

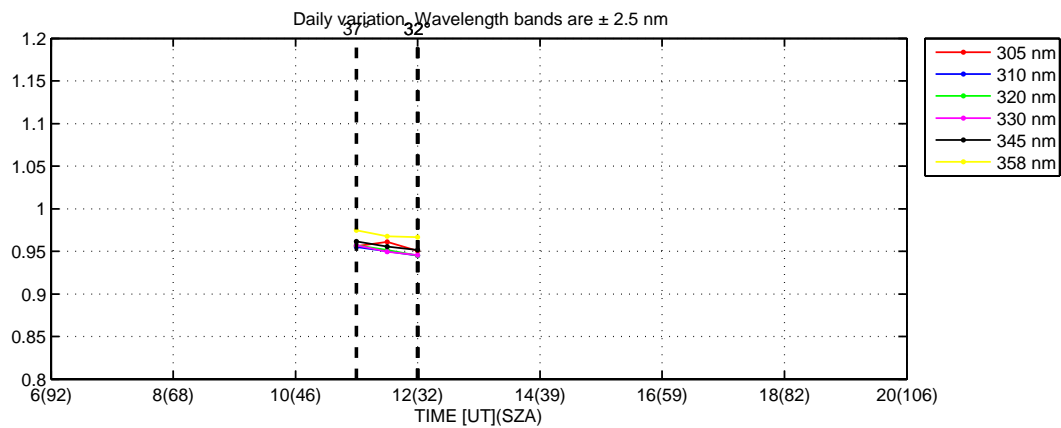
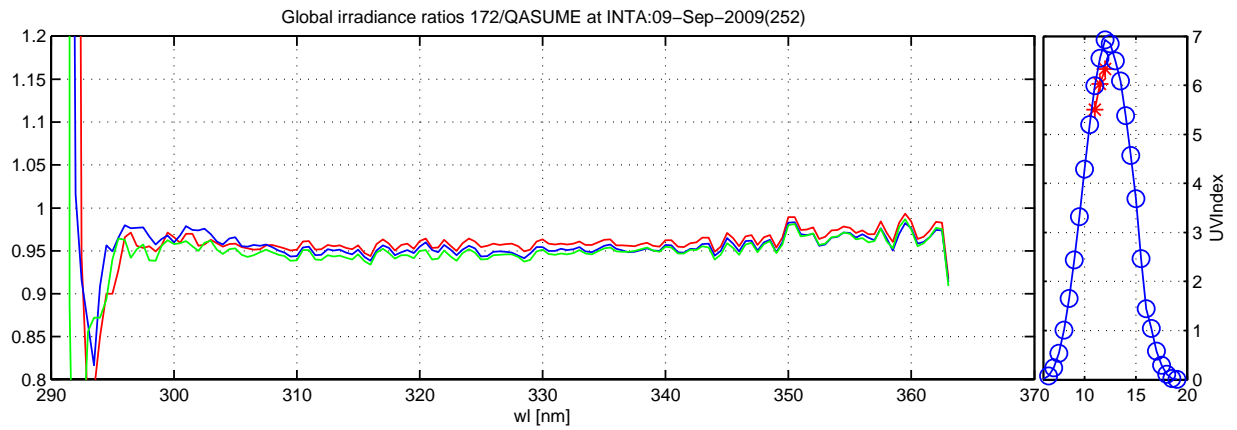
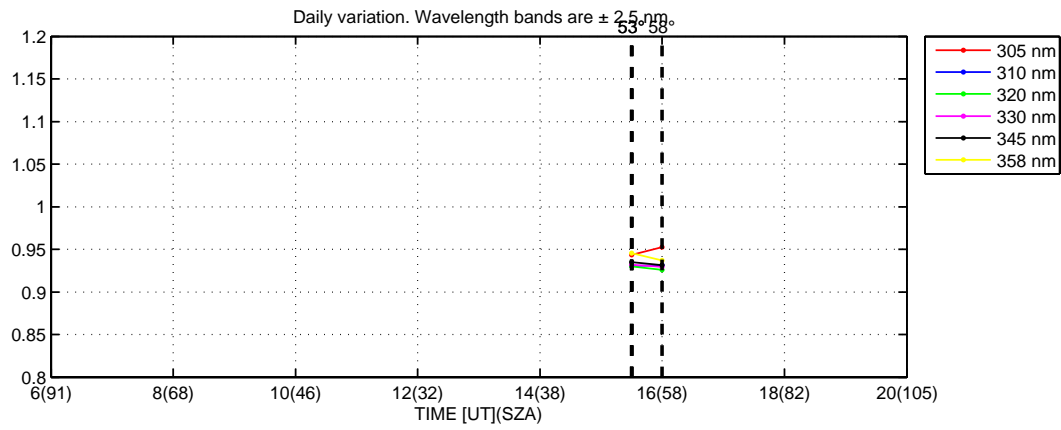
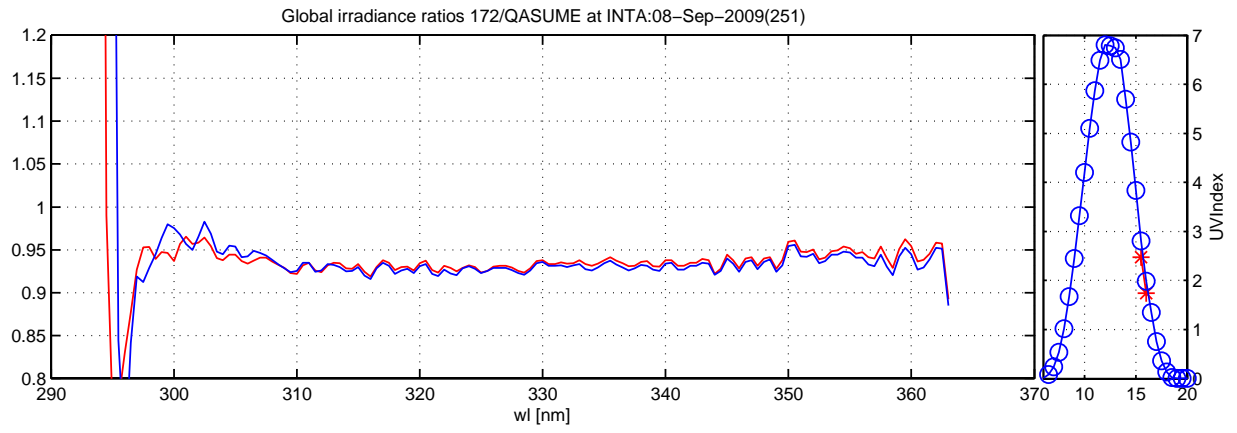

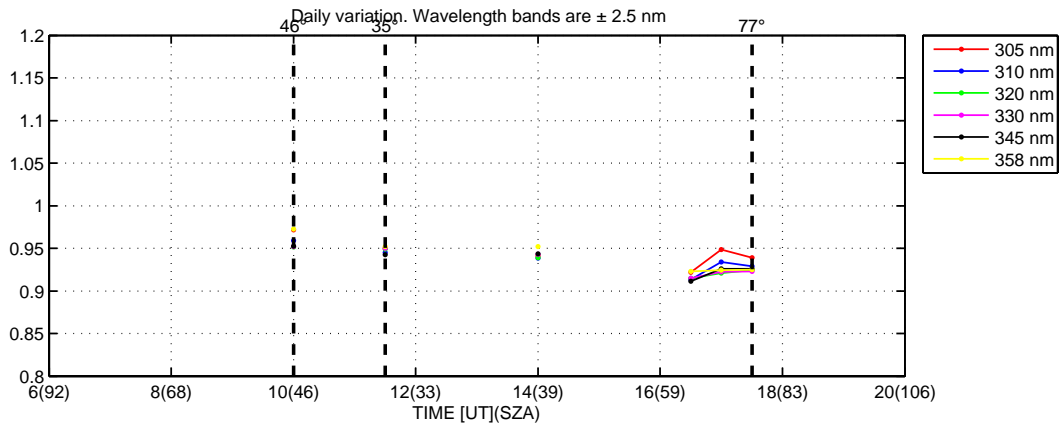
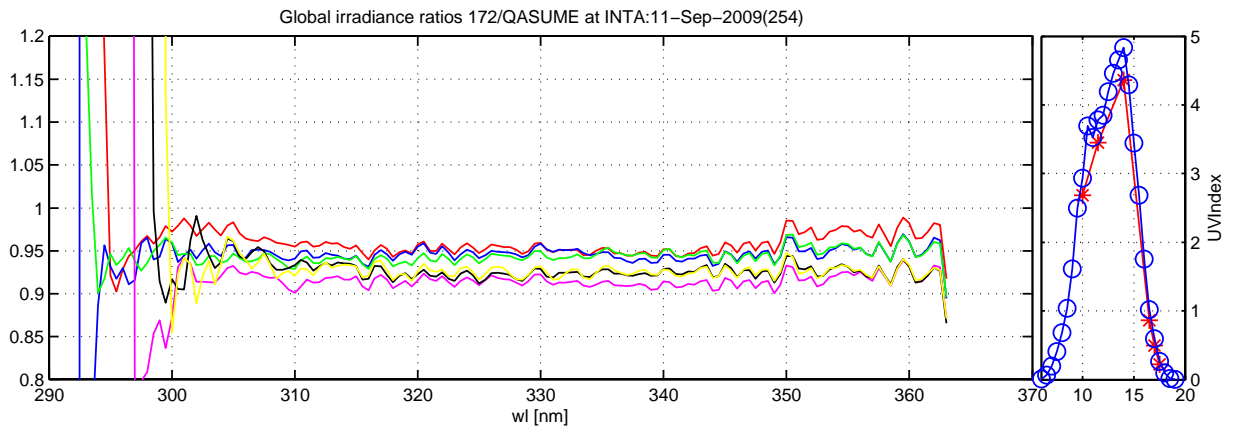
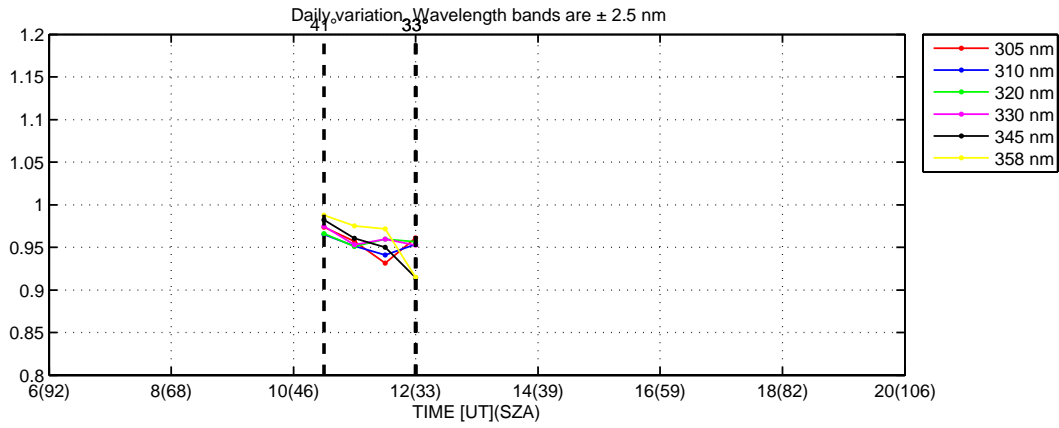
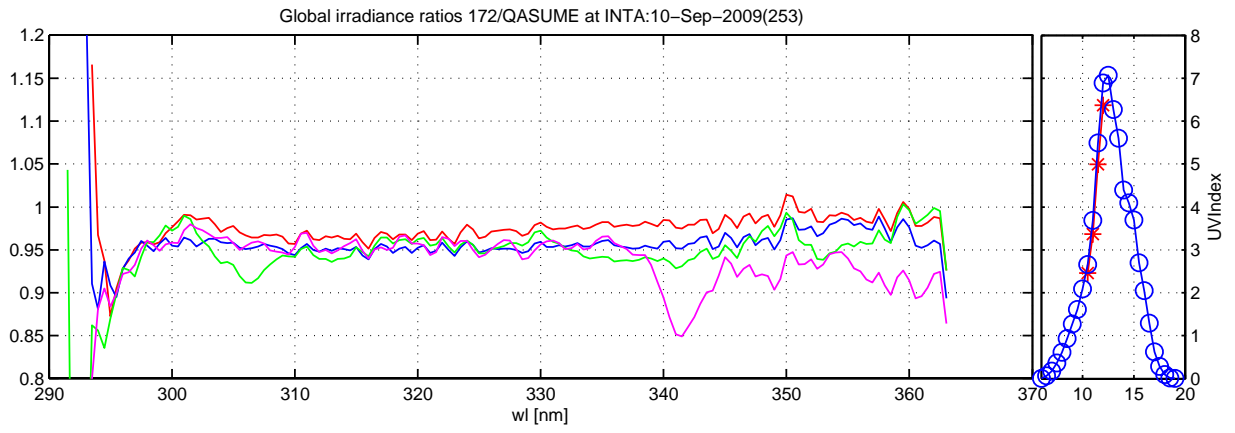

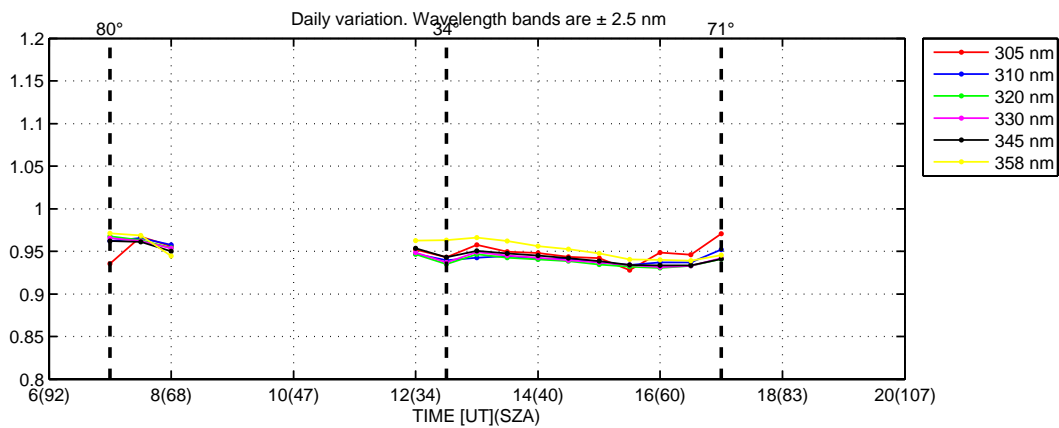
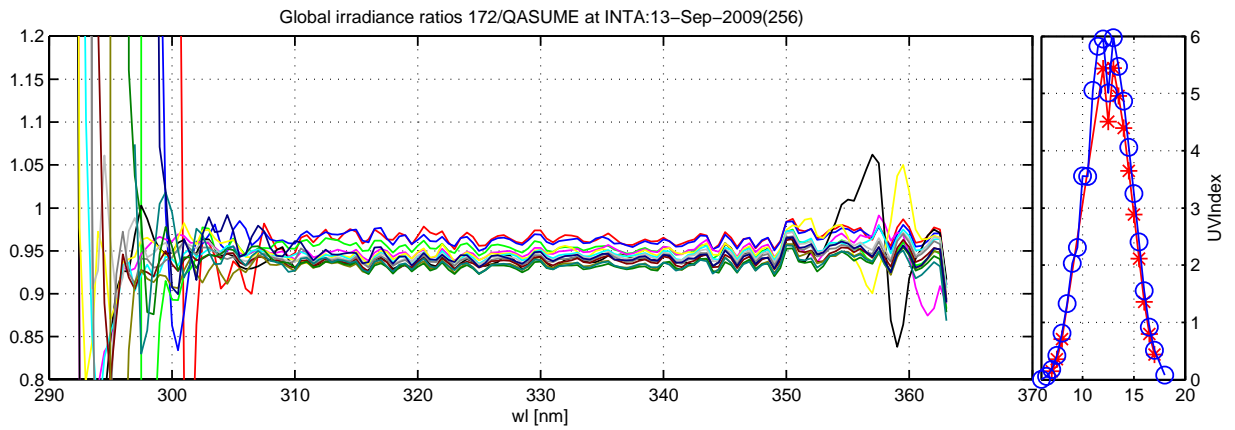
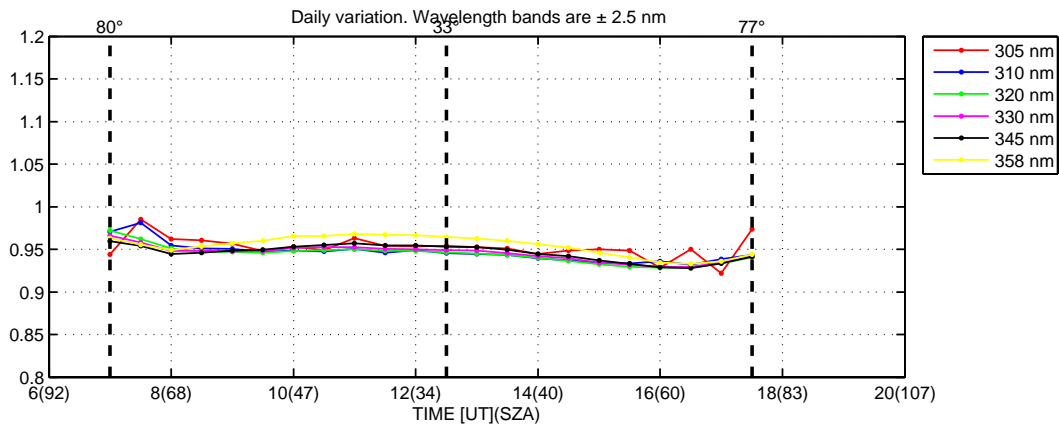
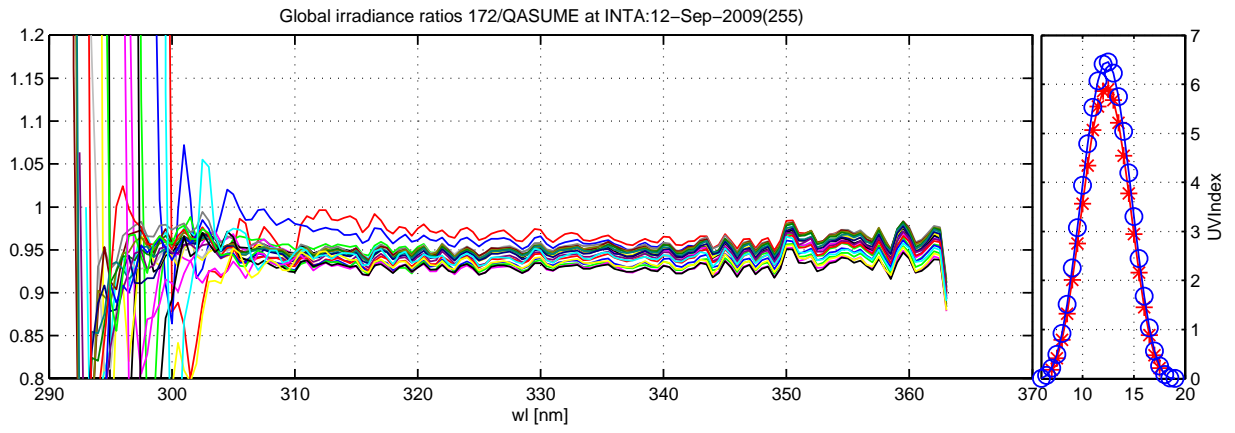

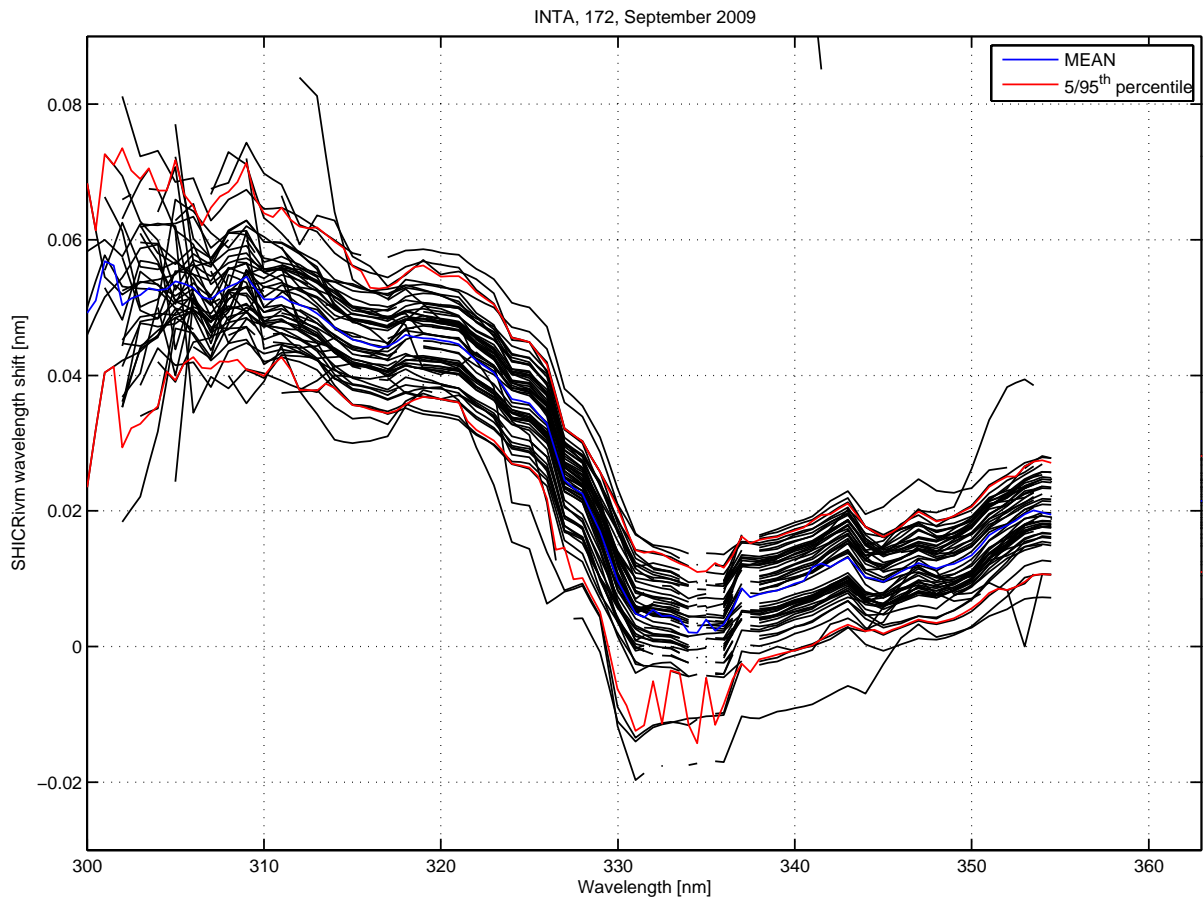
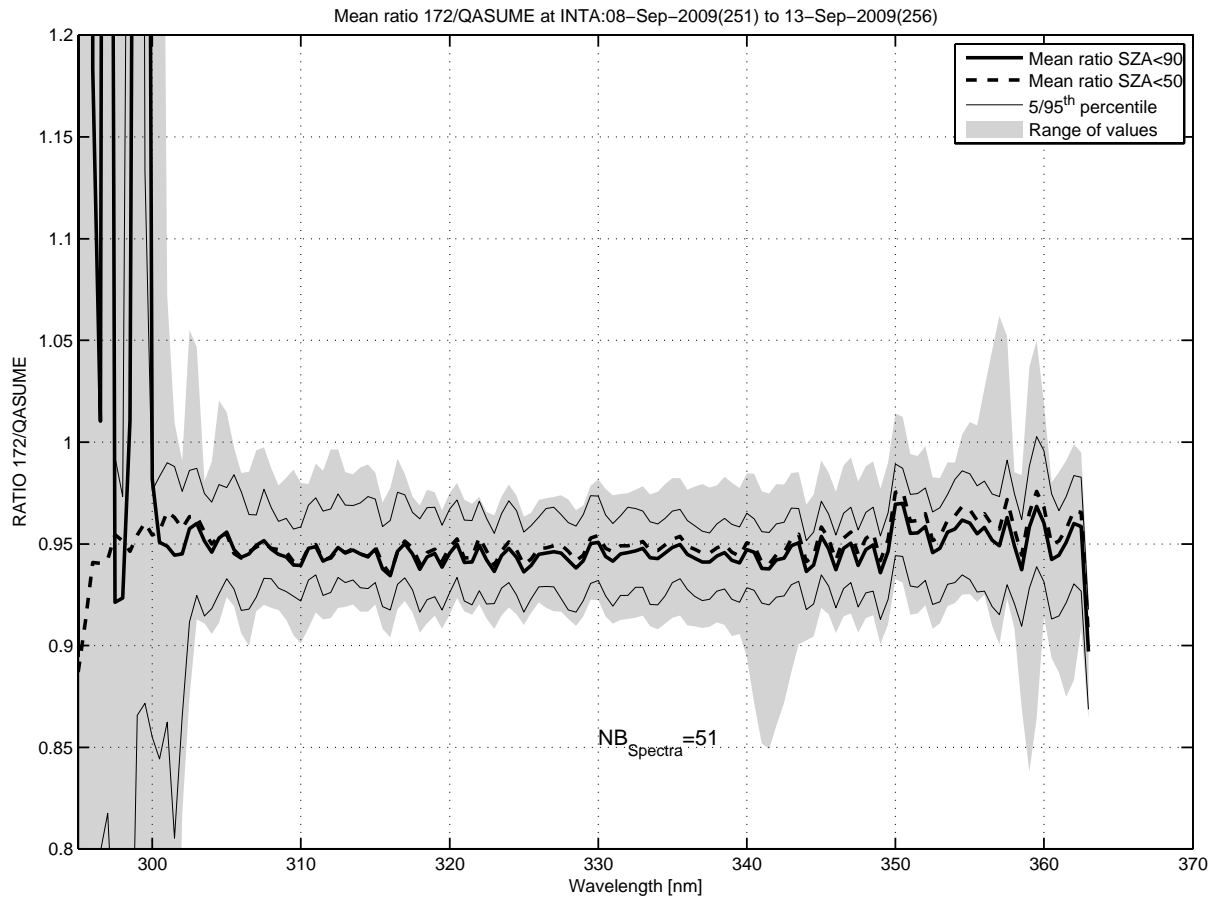

UV Index INTA, September 2009

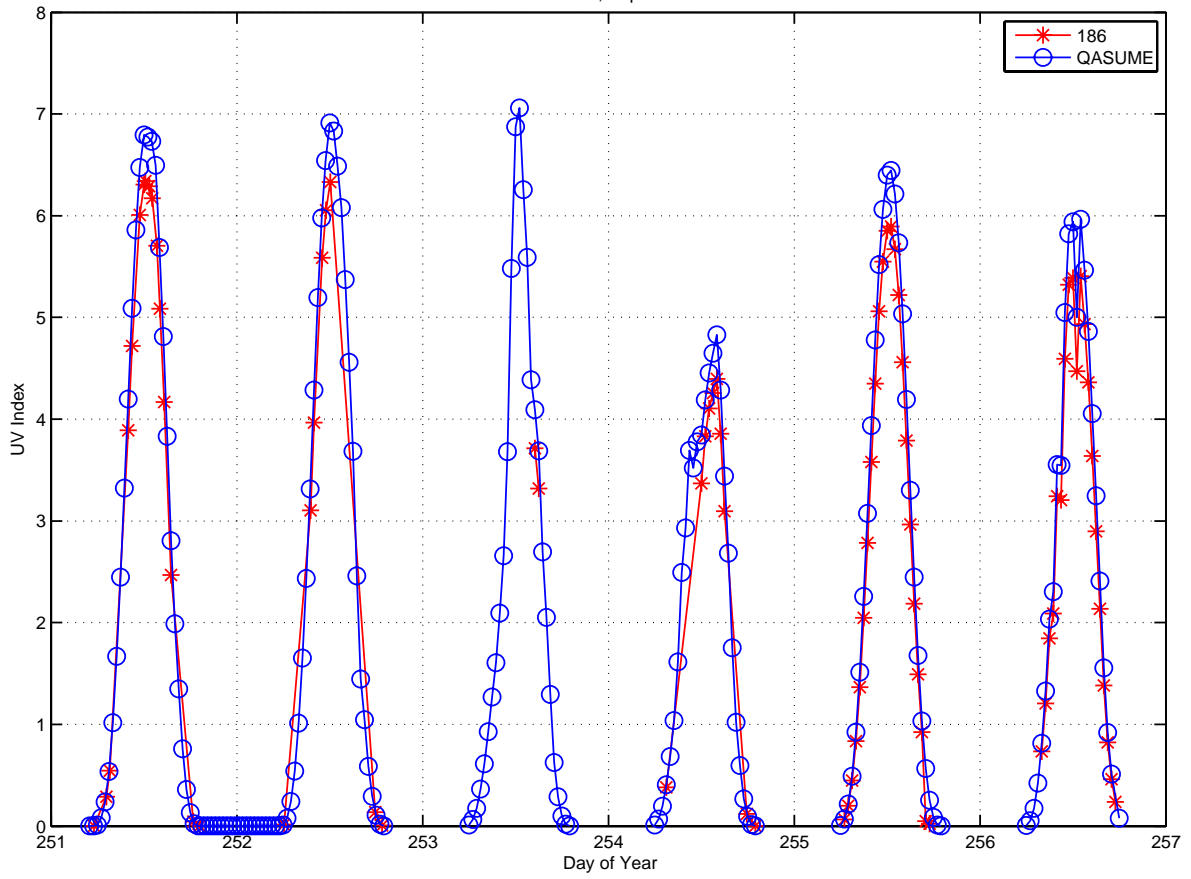

Global irradiance ratios 186/QASUME at INTA:08-Sep-2009(251) to 13-Sep-2009(256)

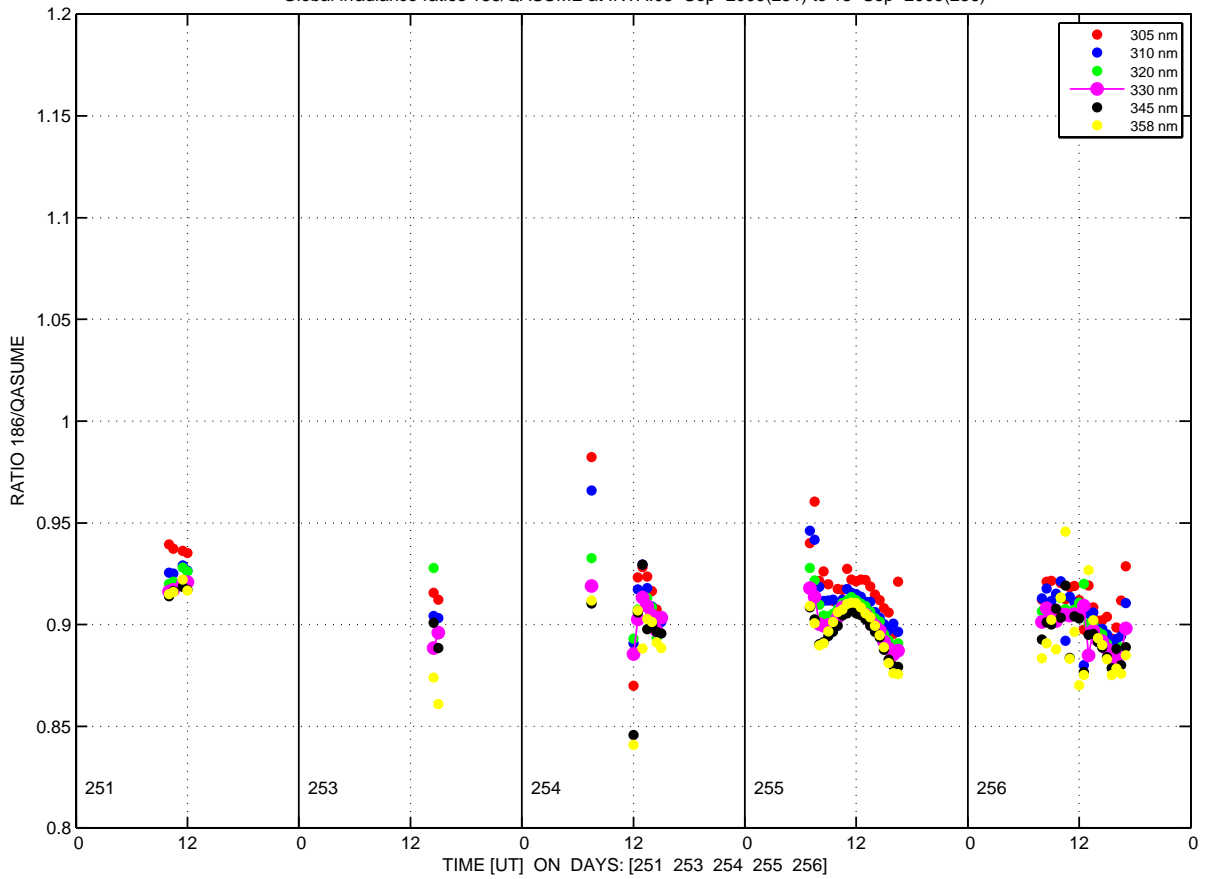

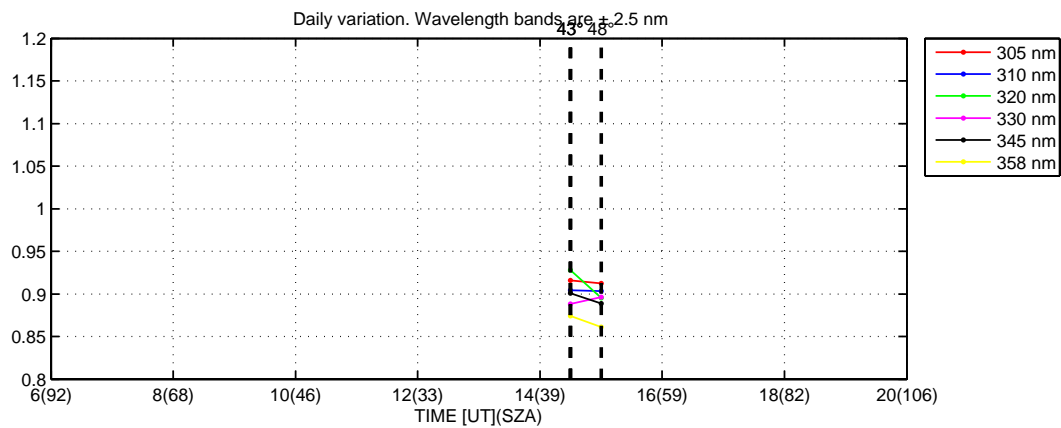
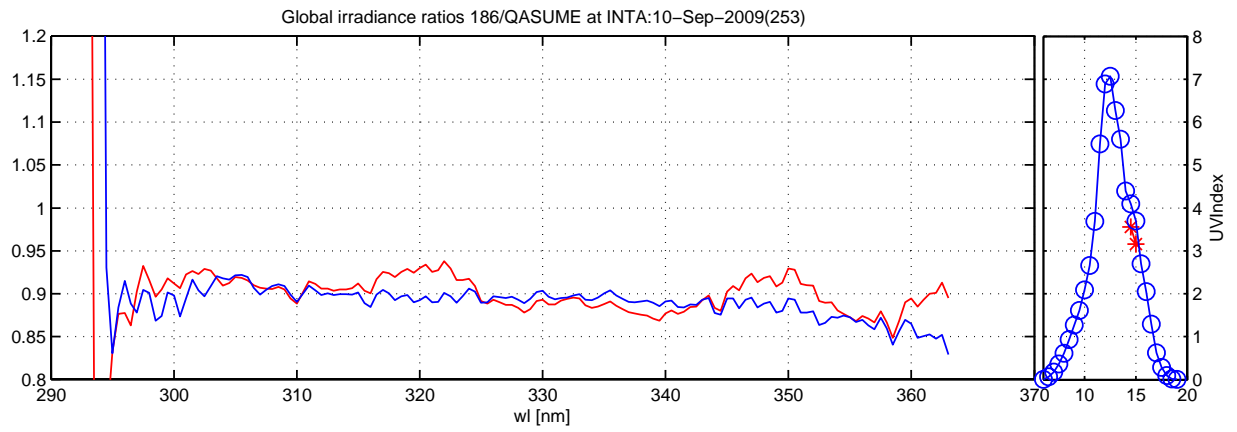
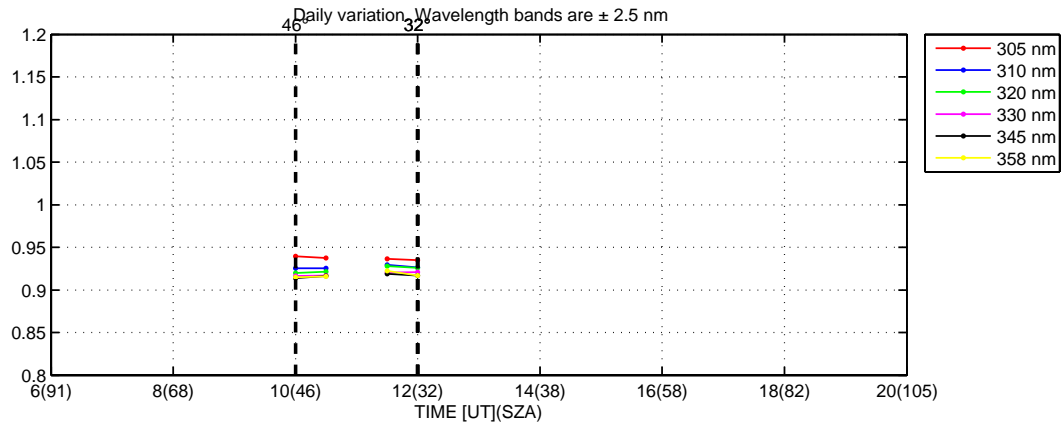
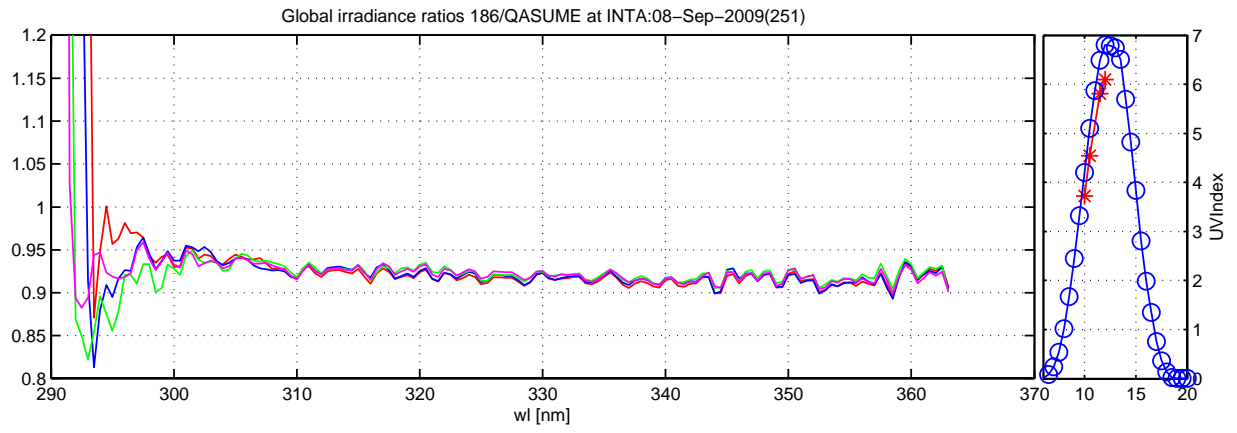

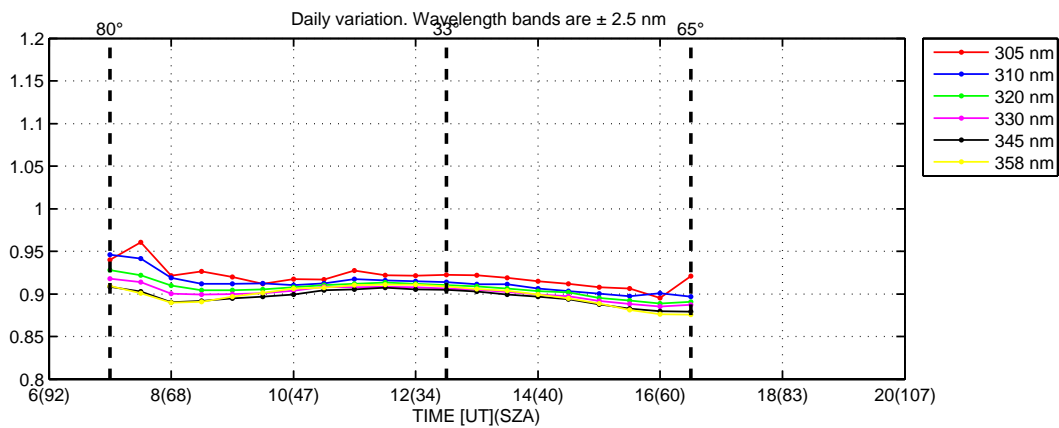
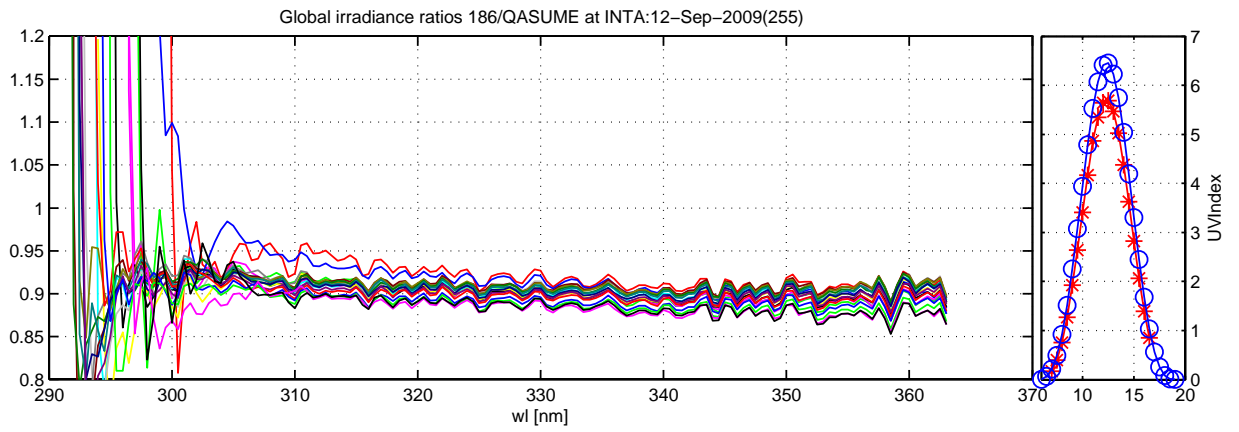
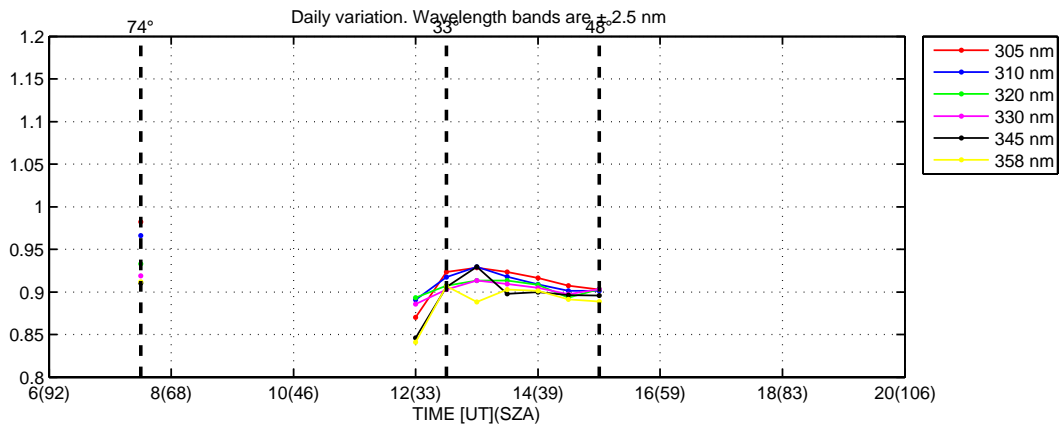
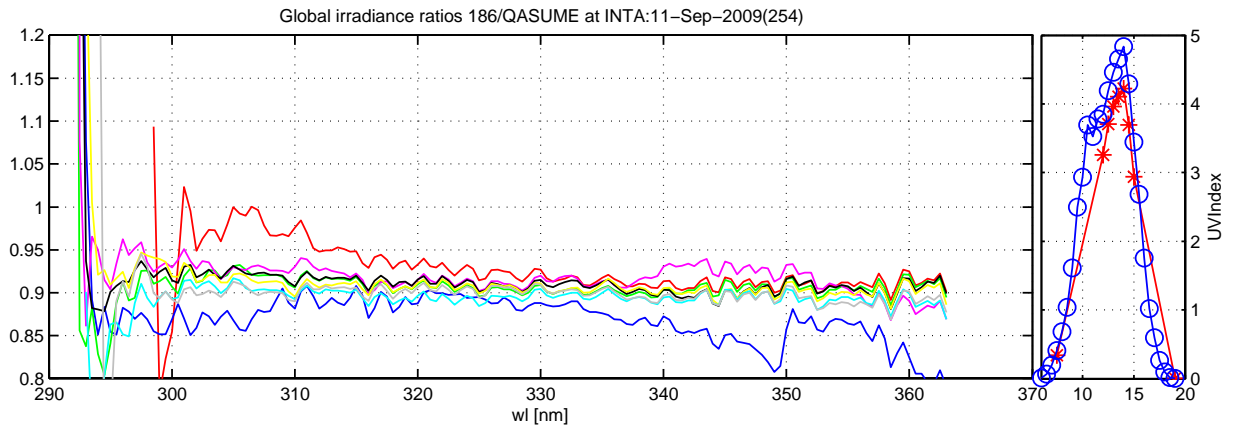



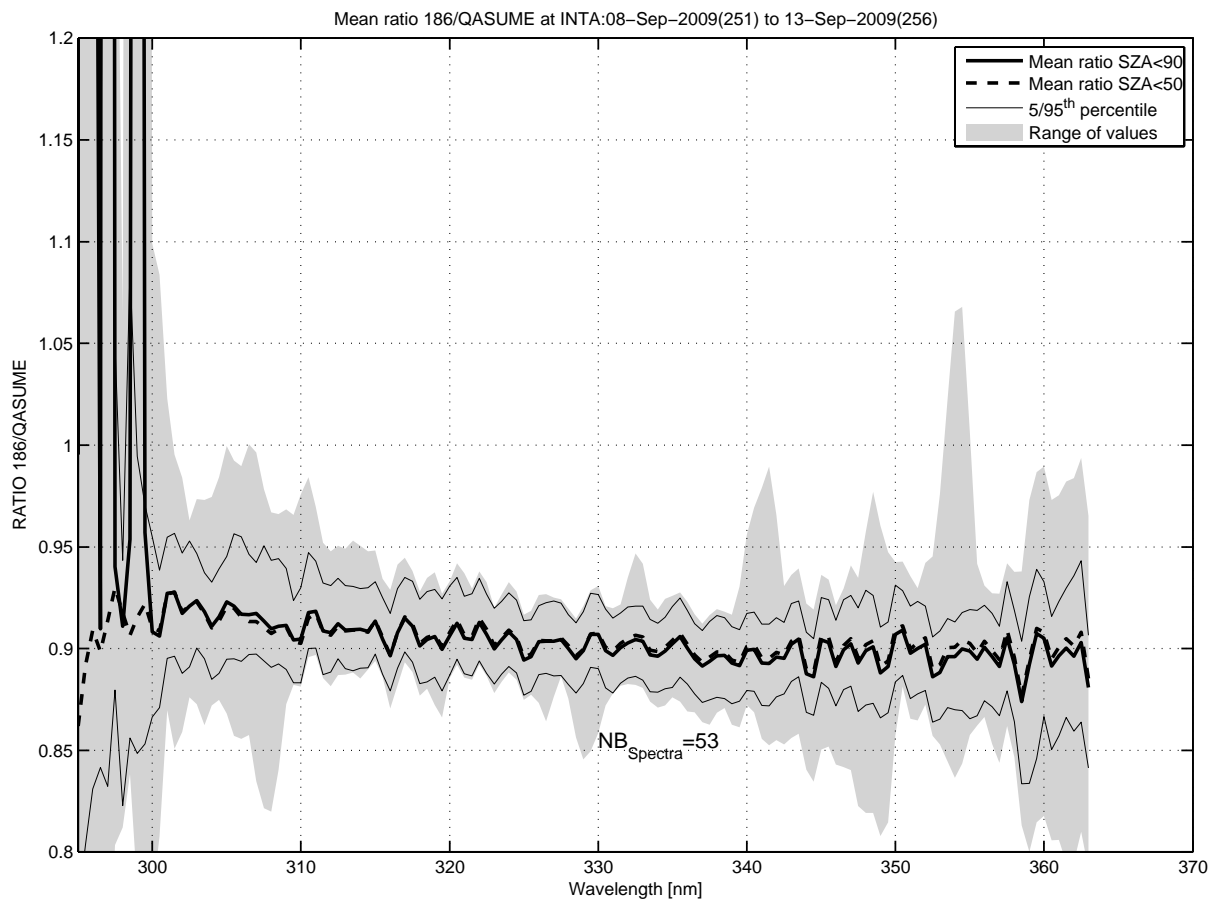
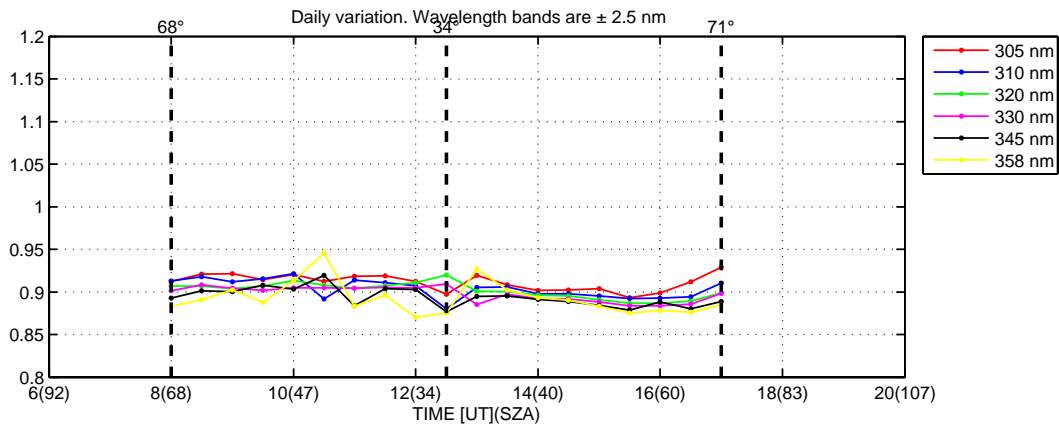
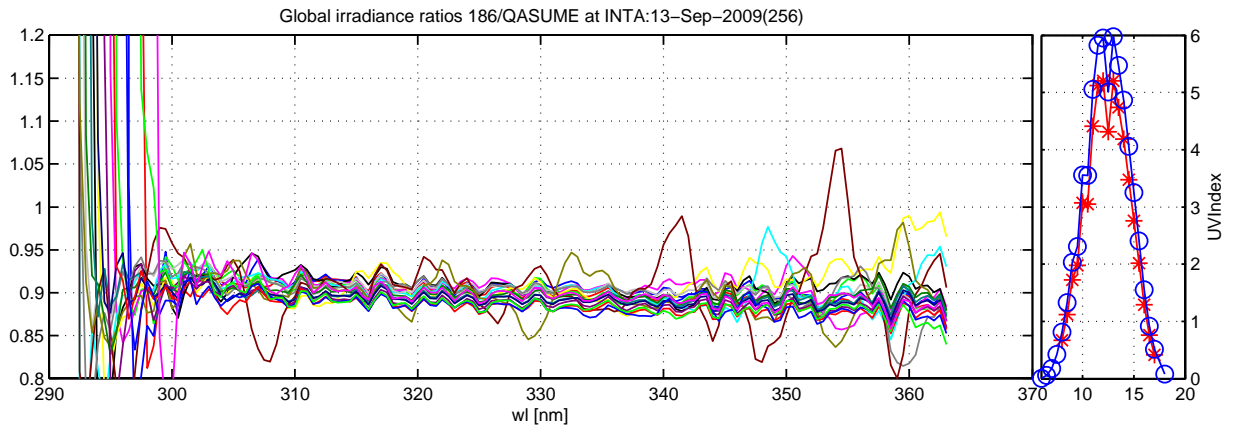

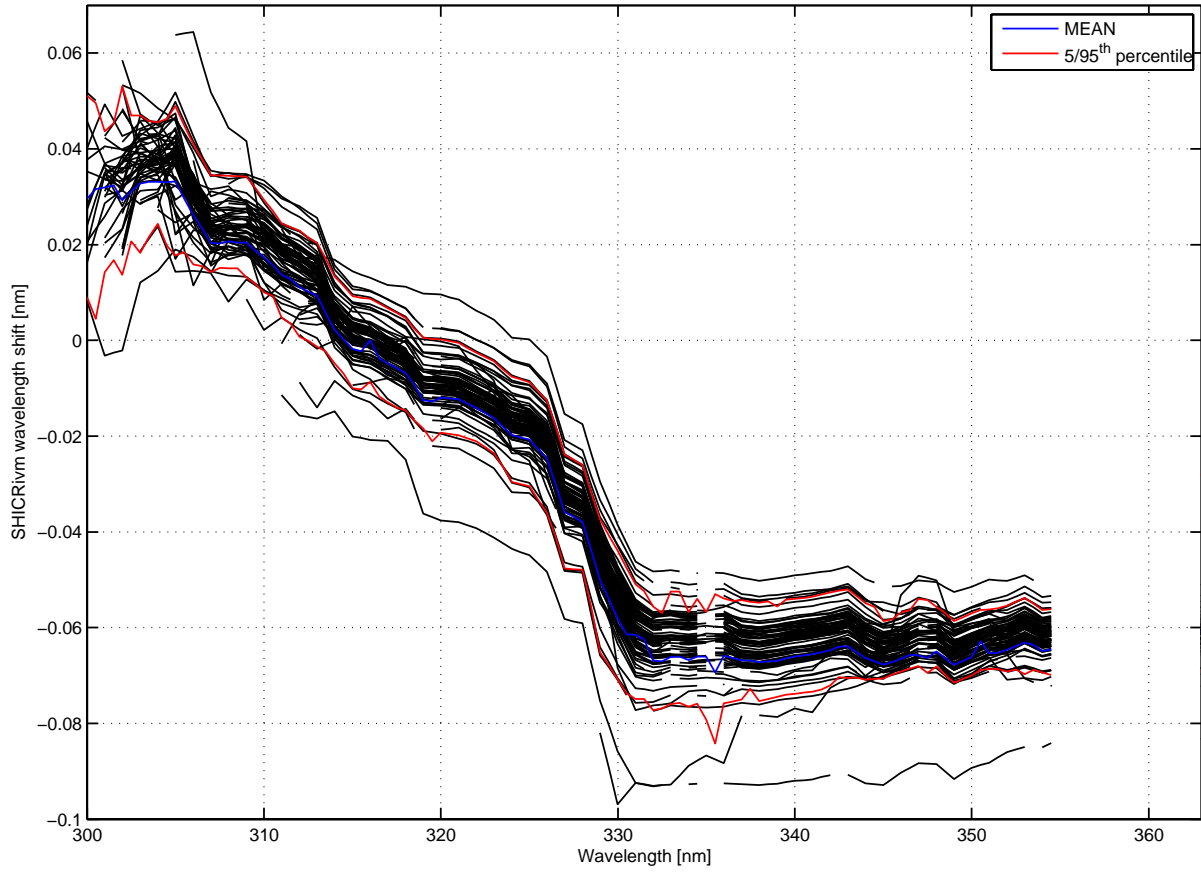

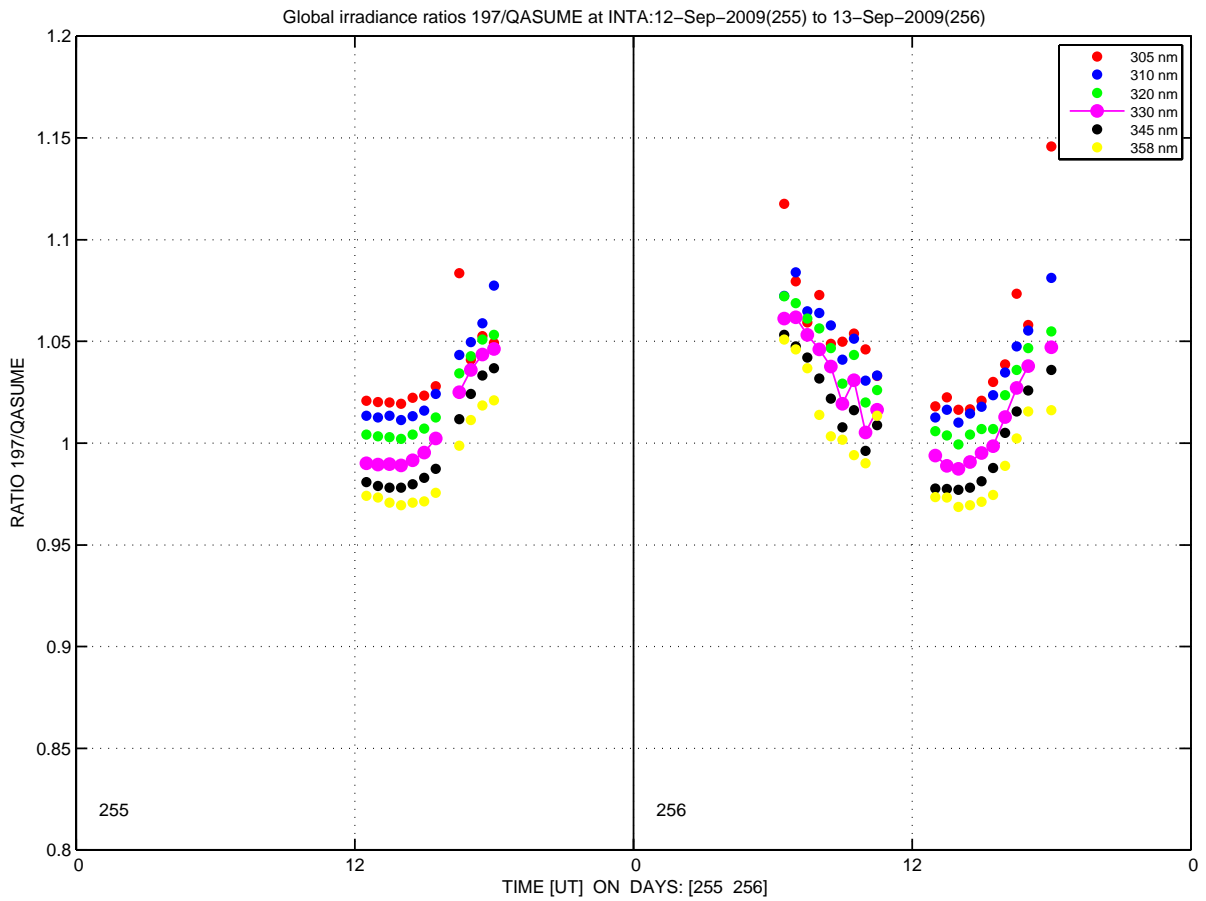
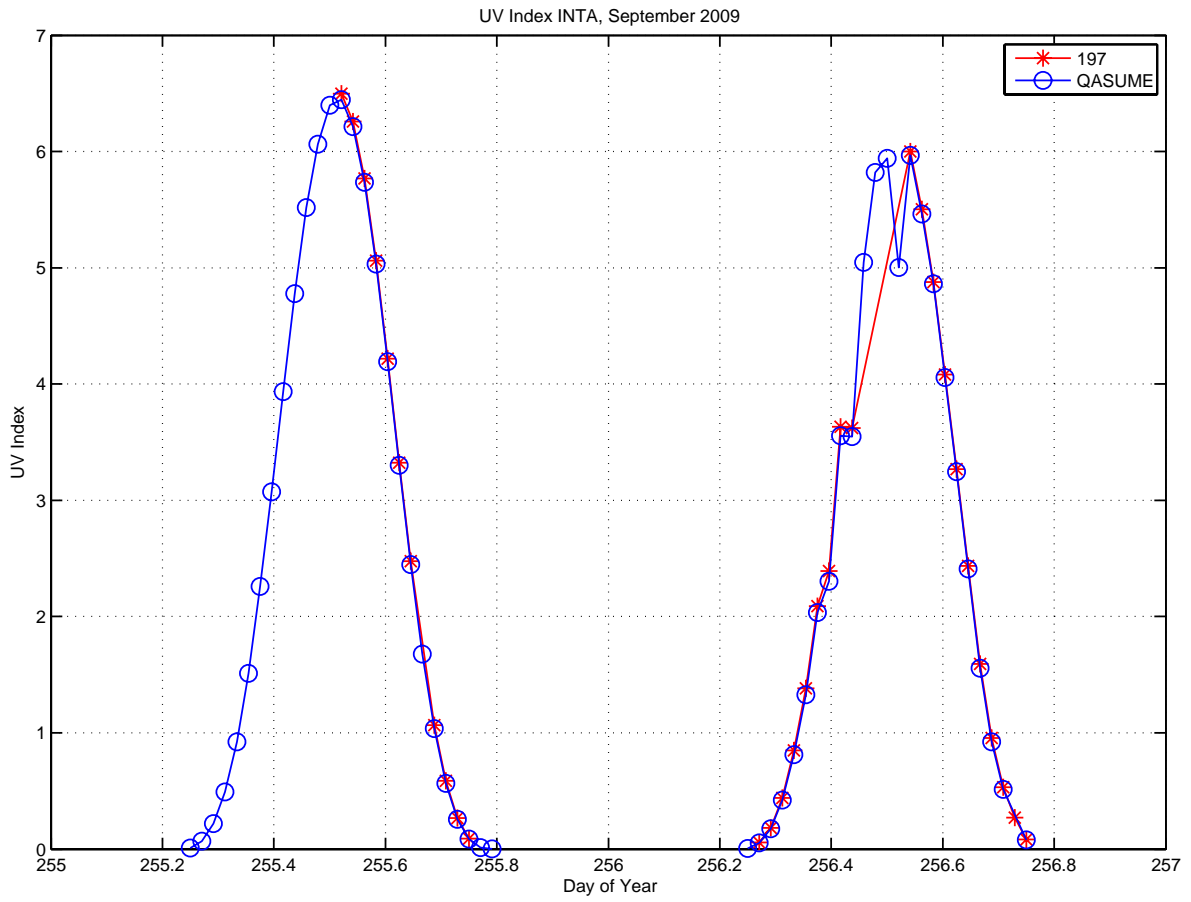

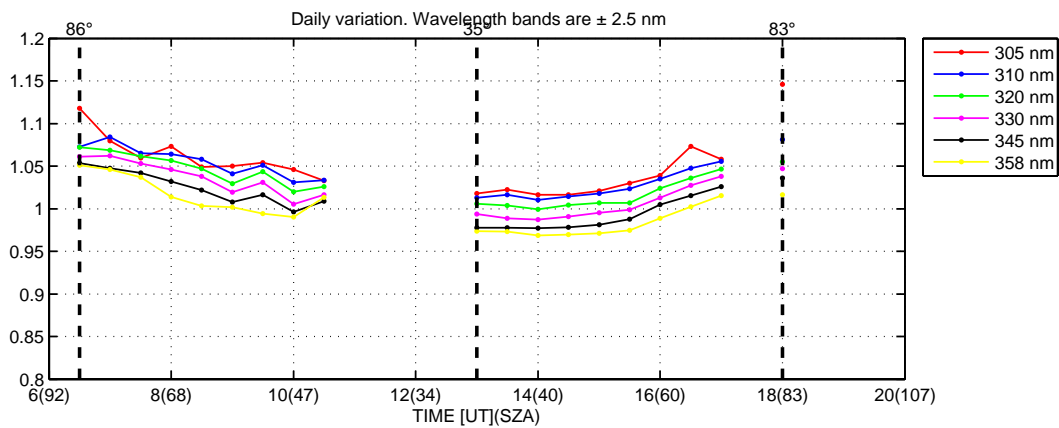
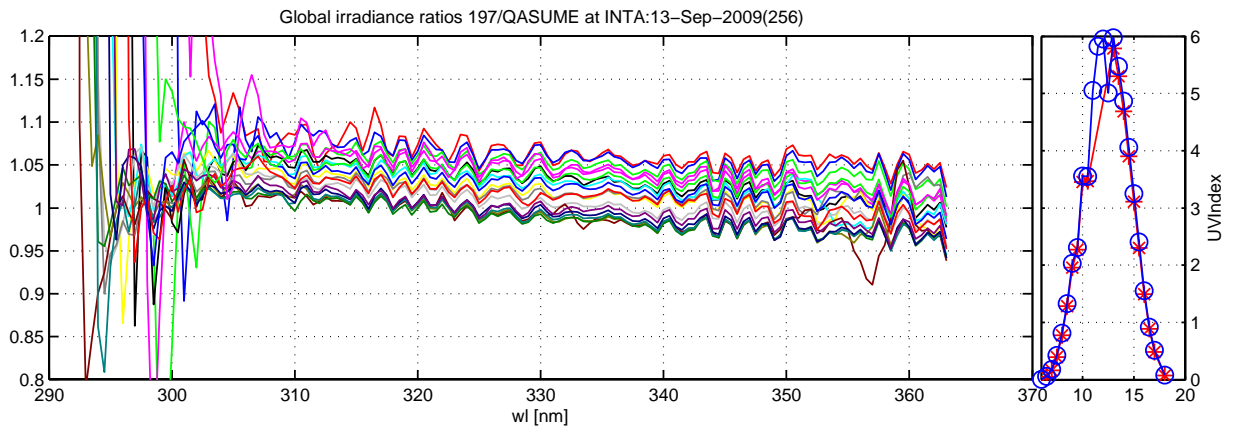
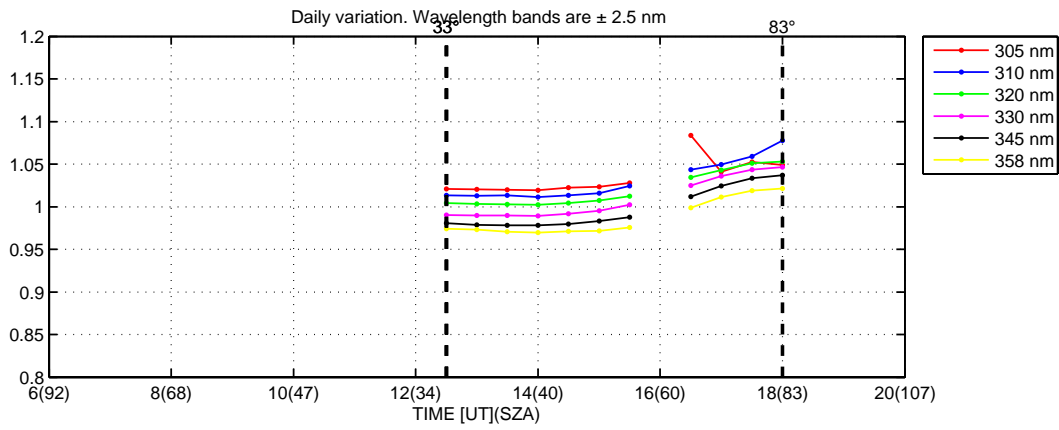
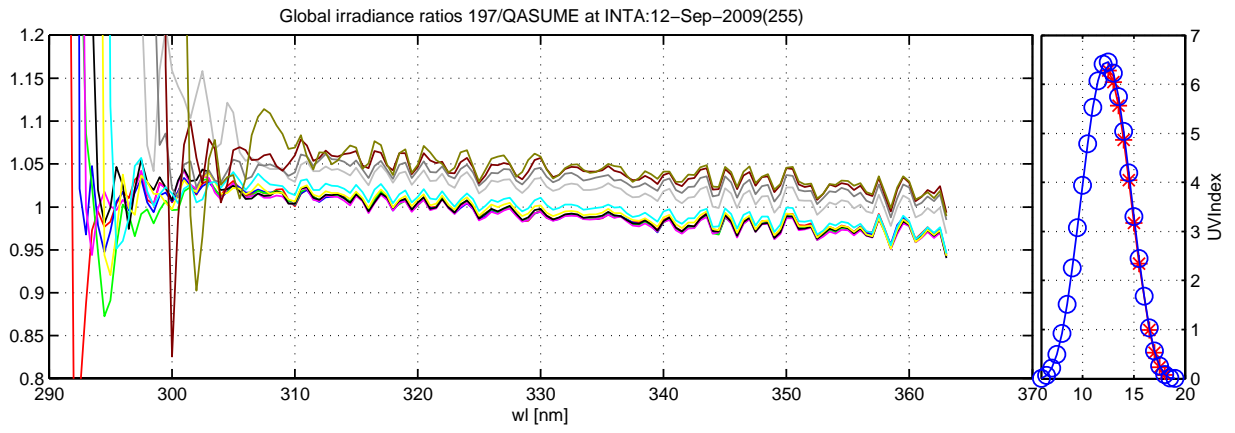

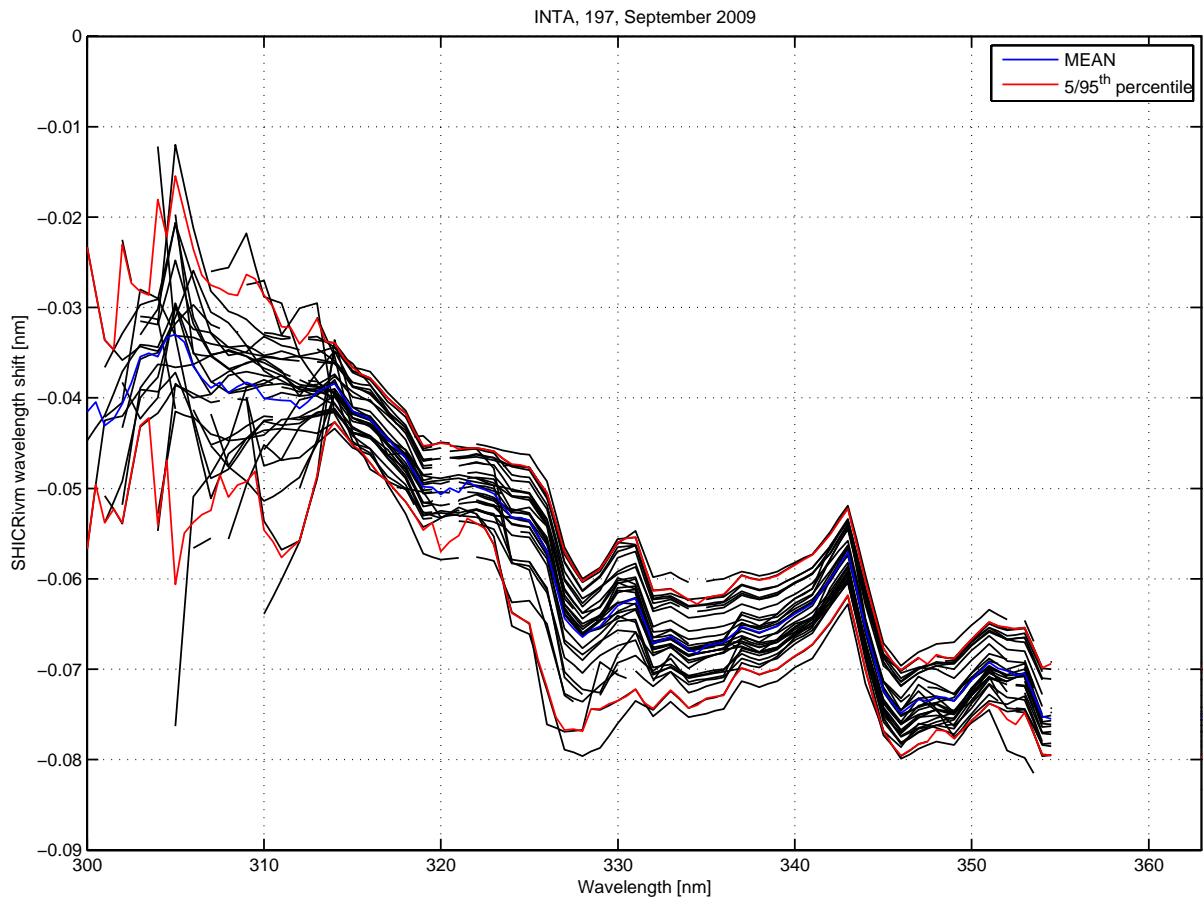
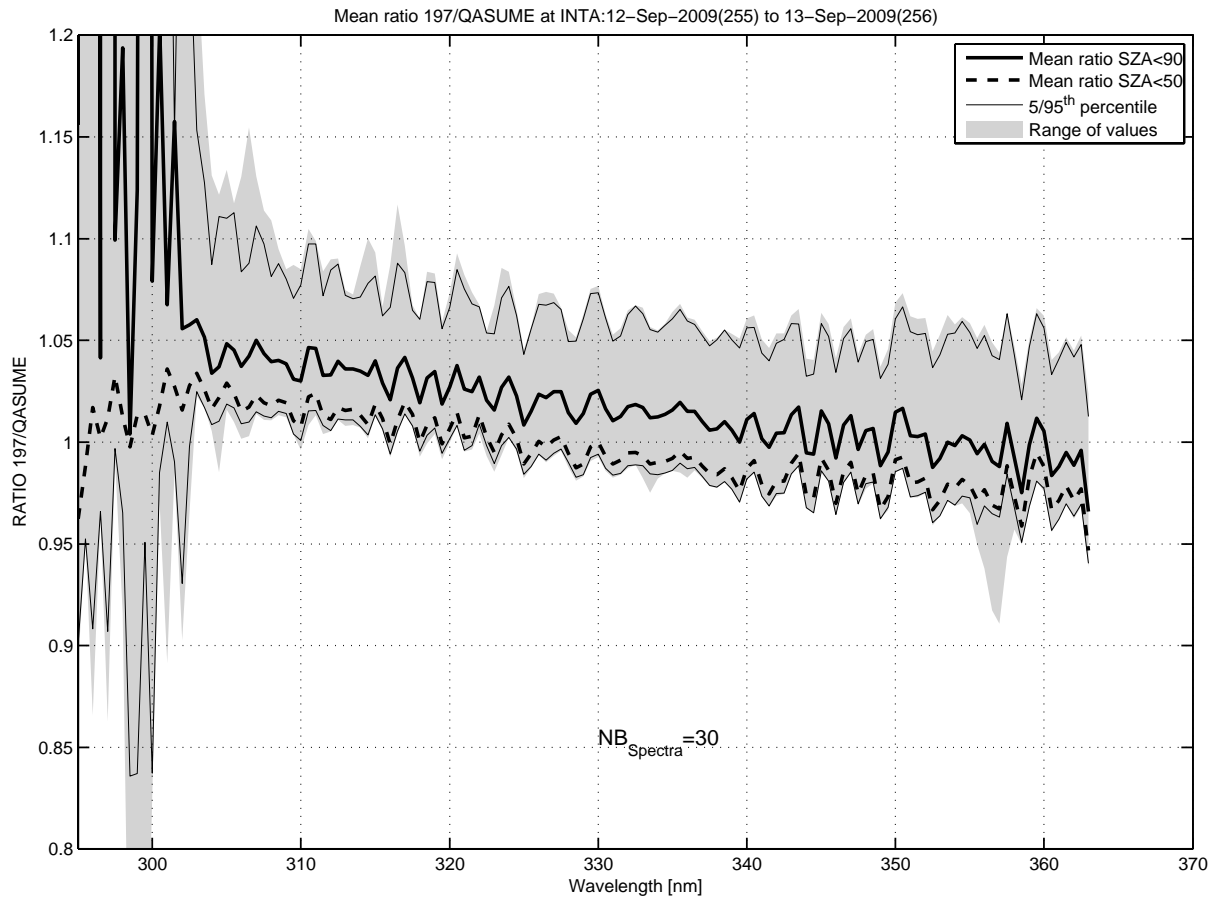

UV Index INTA, September 2009

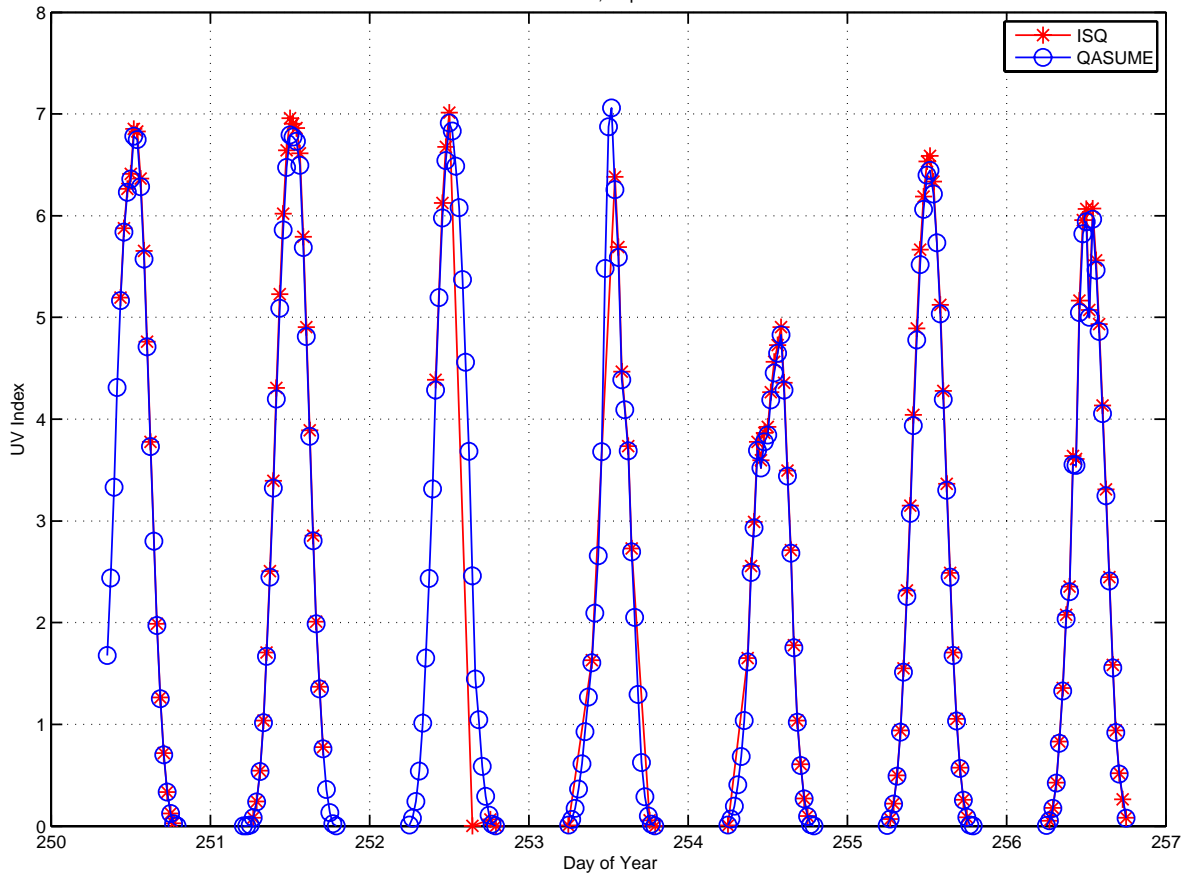

Global irradiance ratios ISQ/QASUME at INTA:07-Sep-2009(250) to 13-Sep-2009(256)

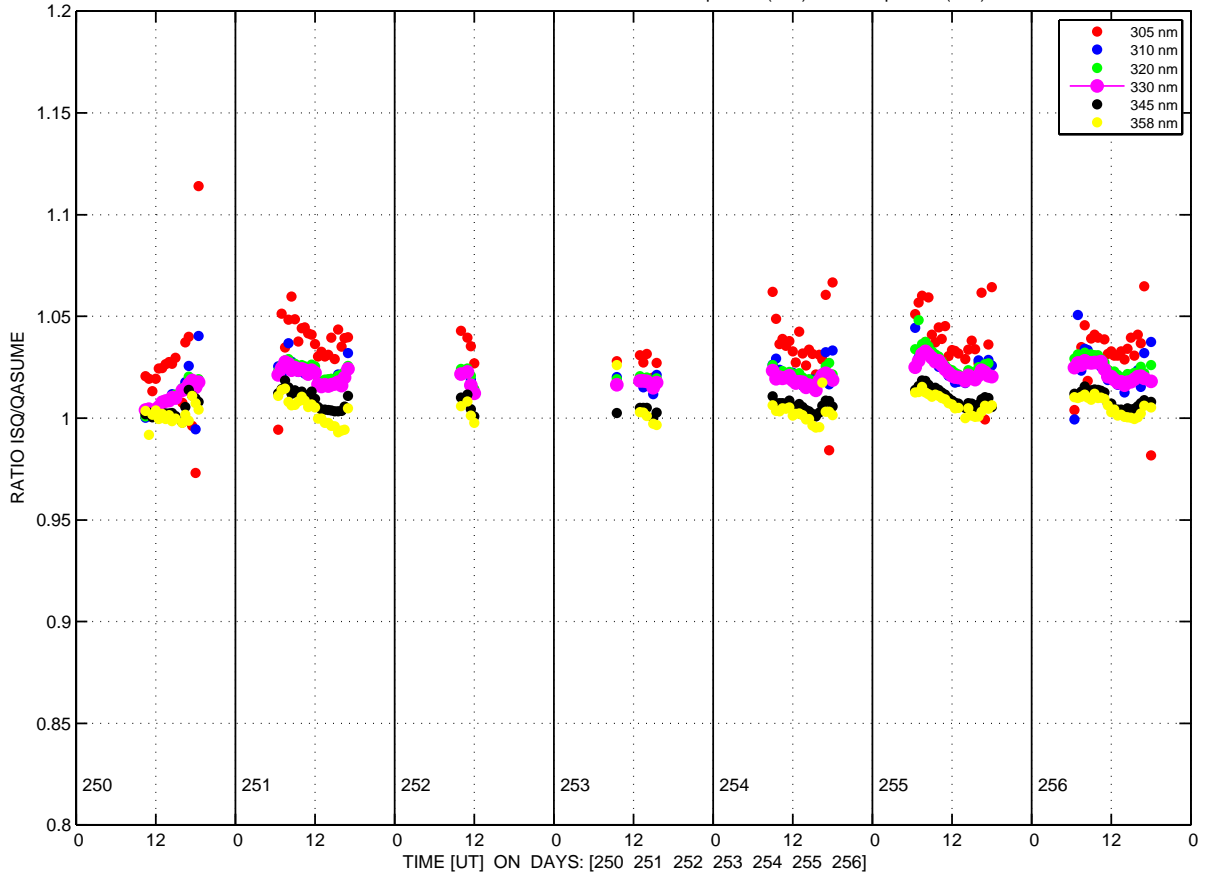

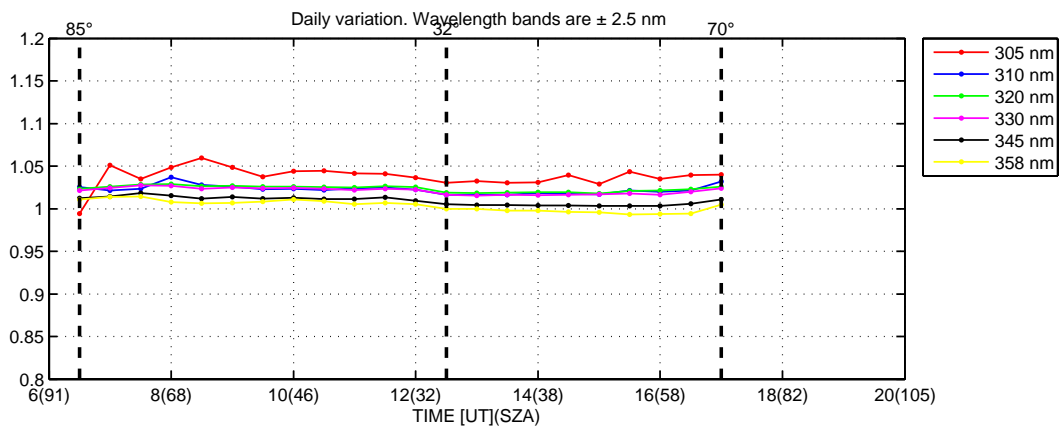
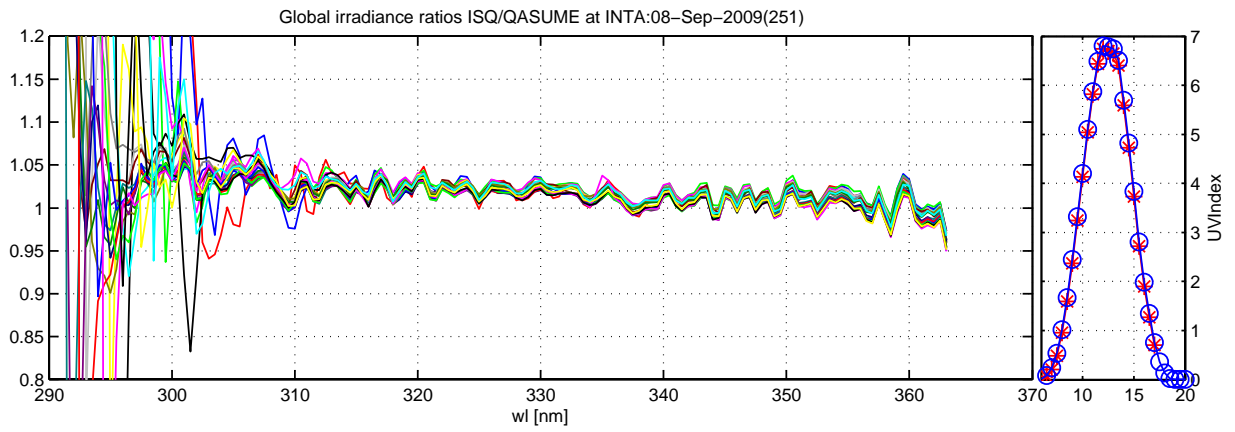
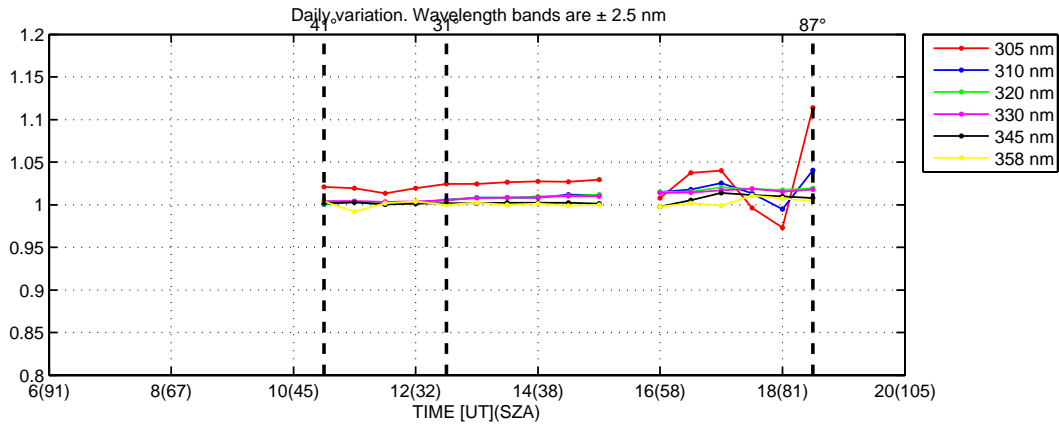
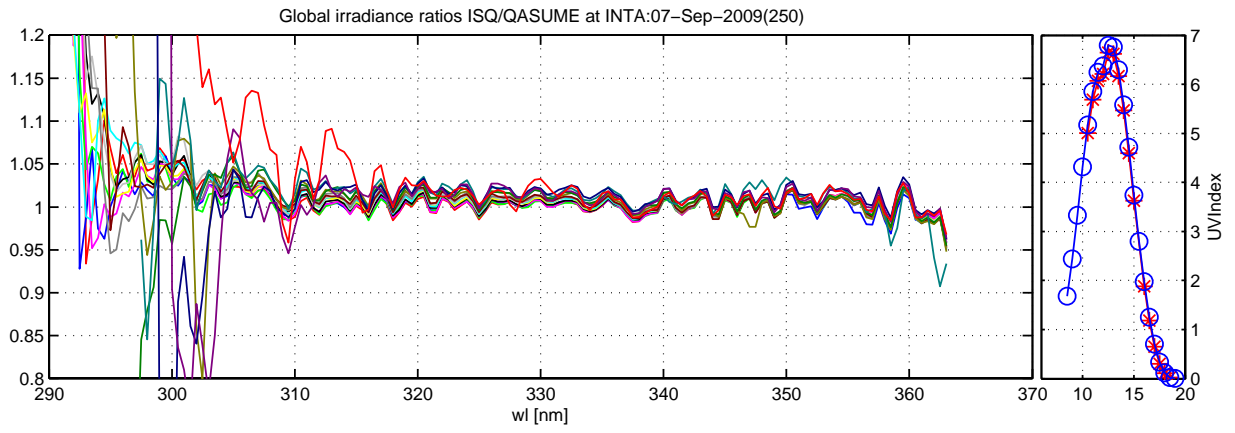

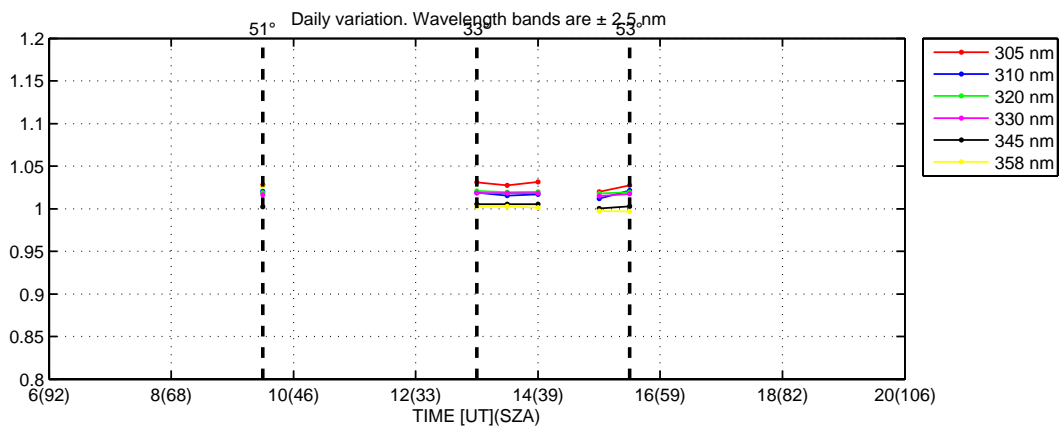
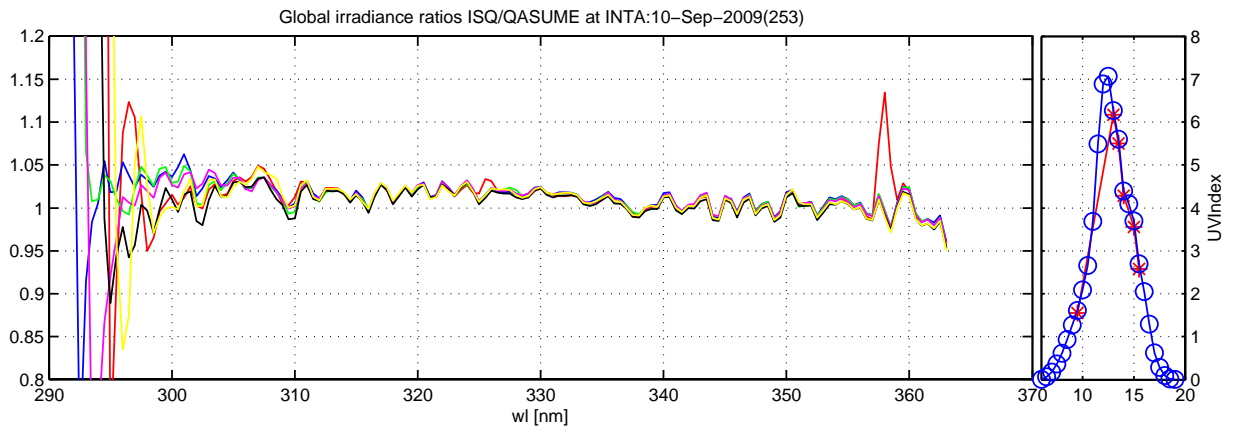
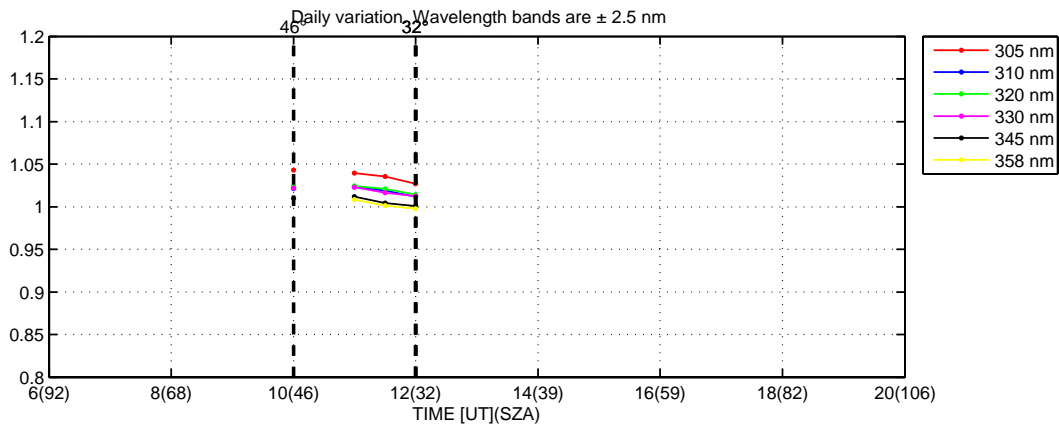
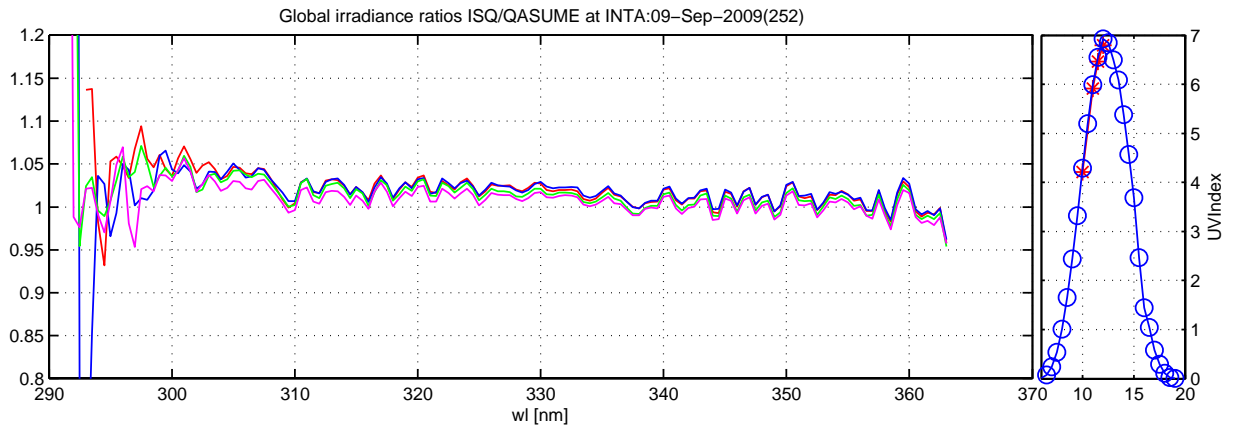



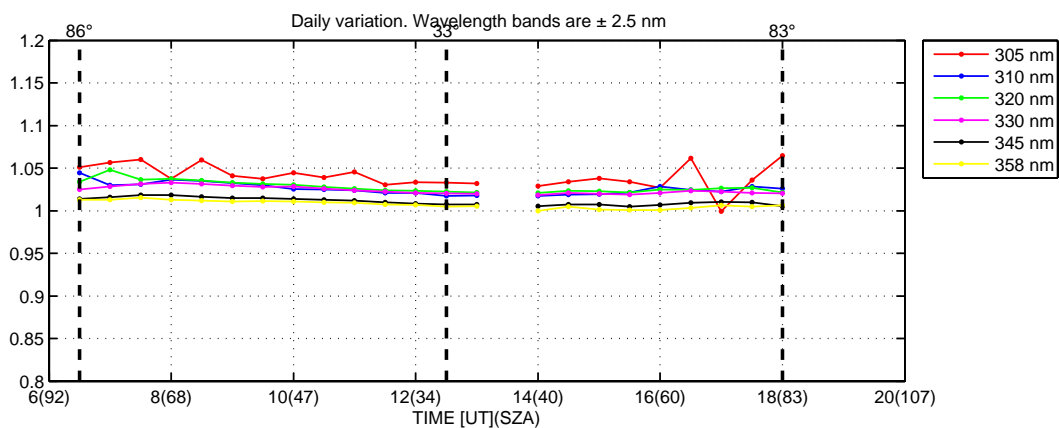
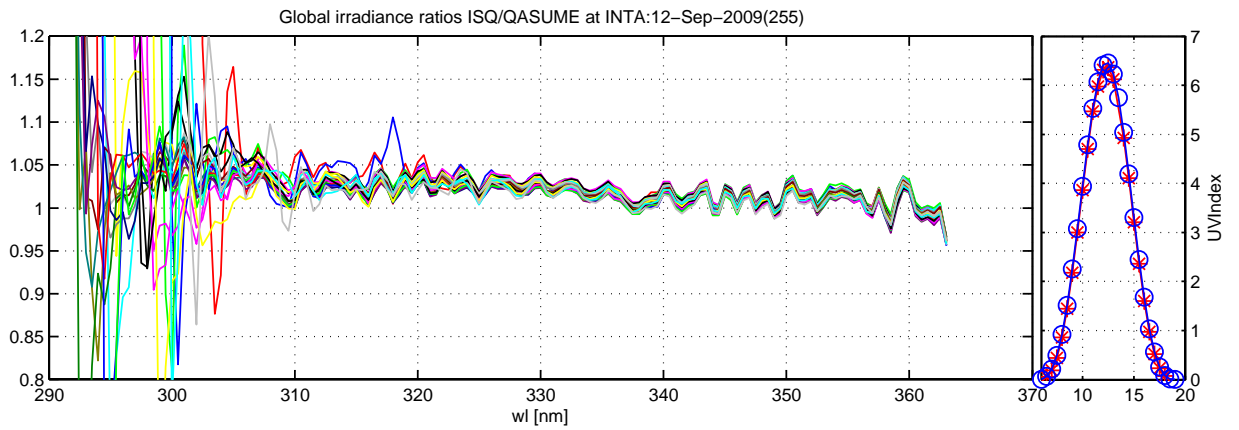
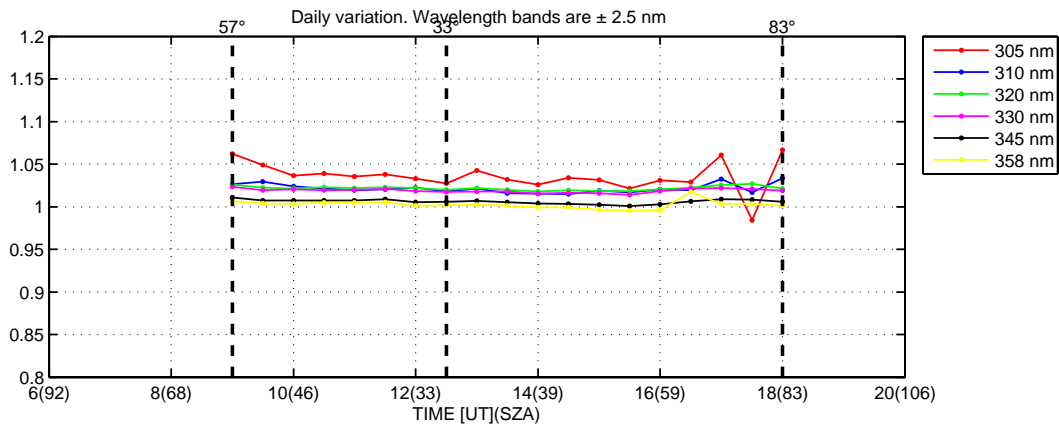
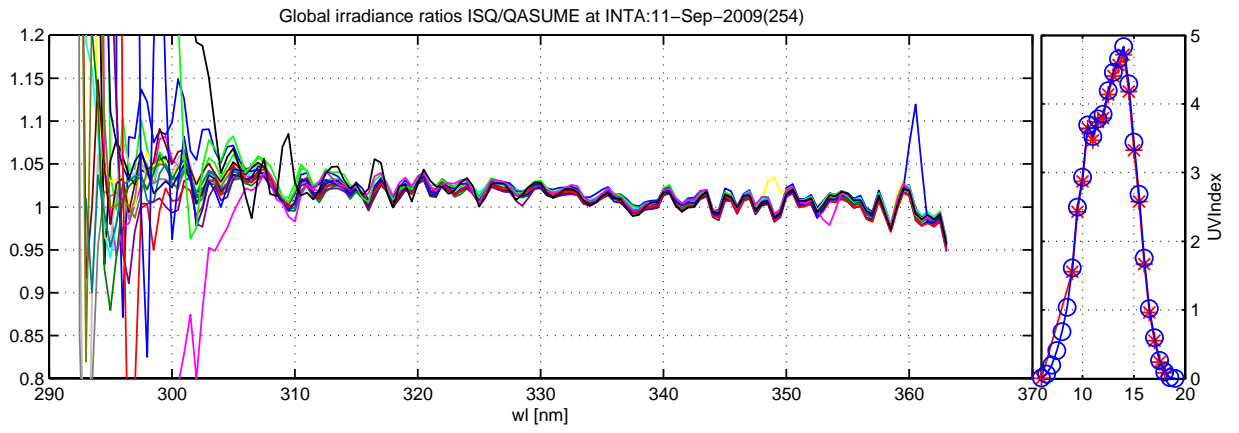

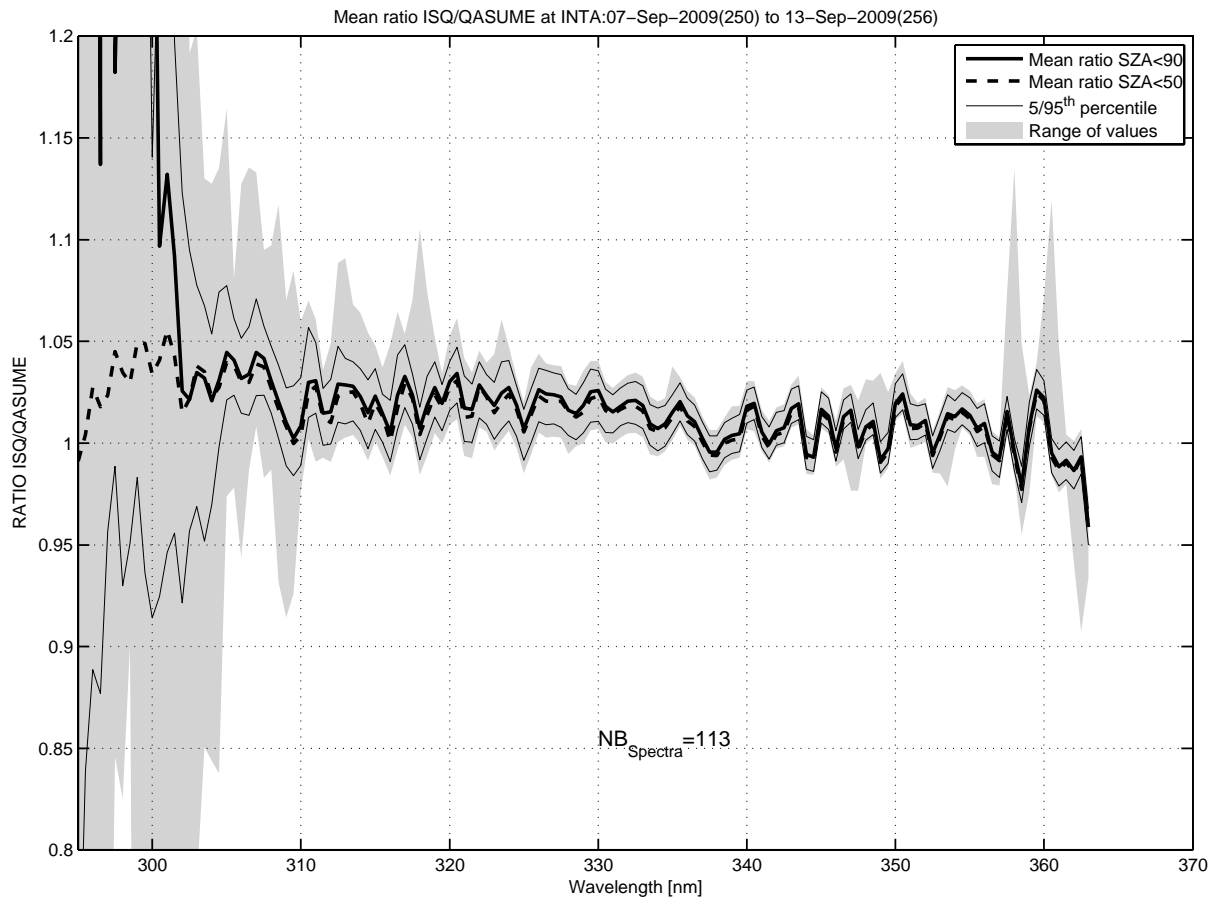
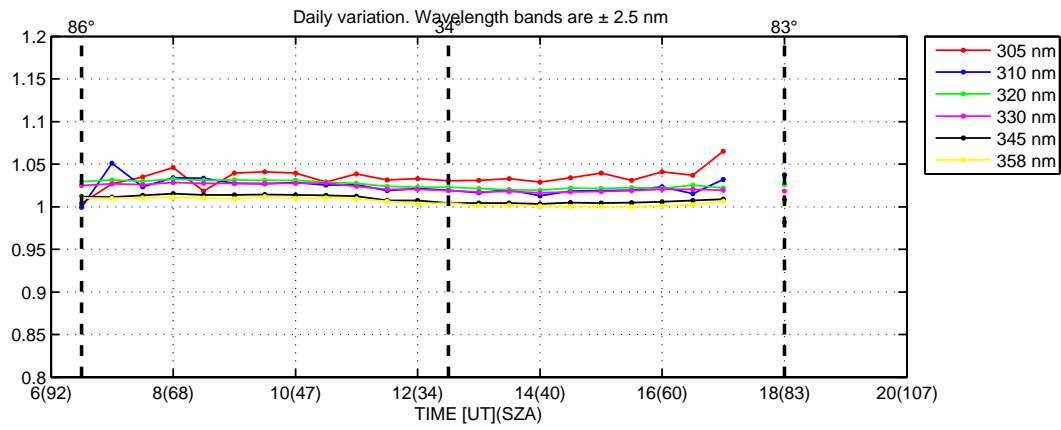
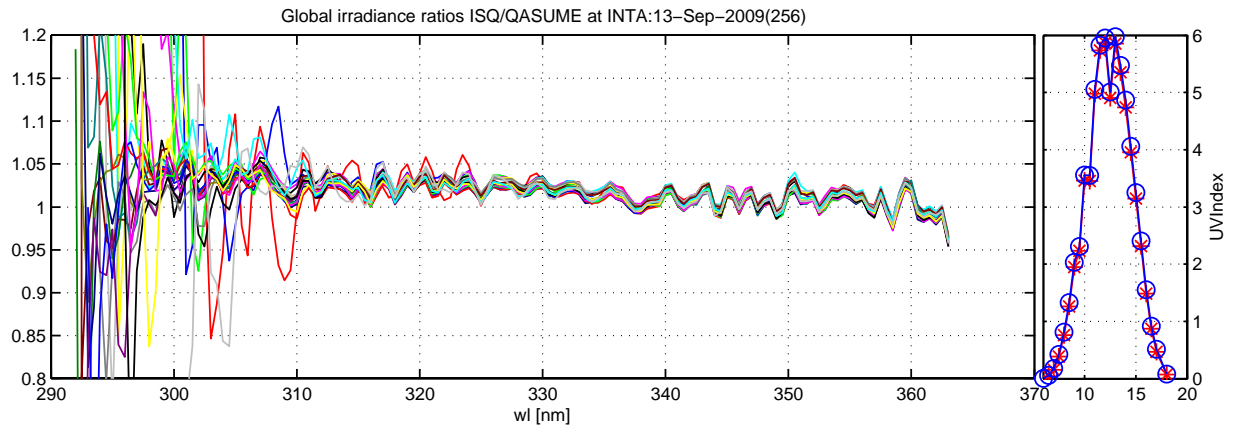

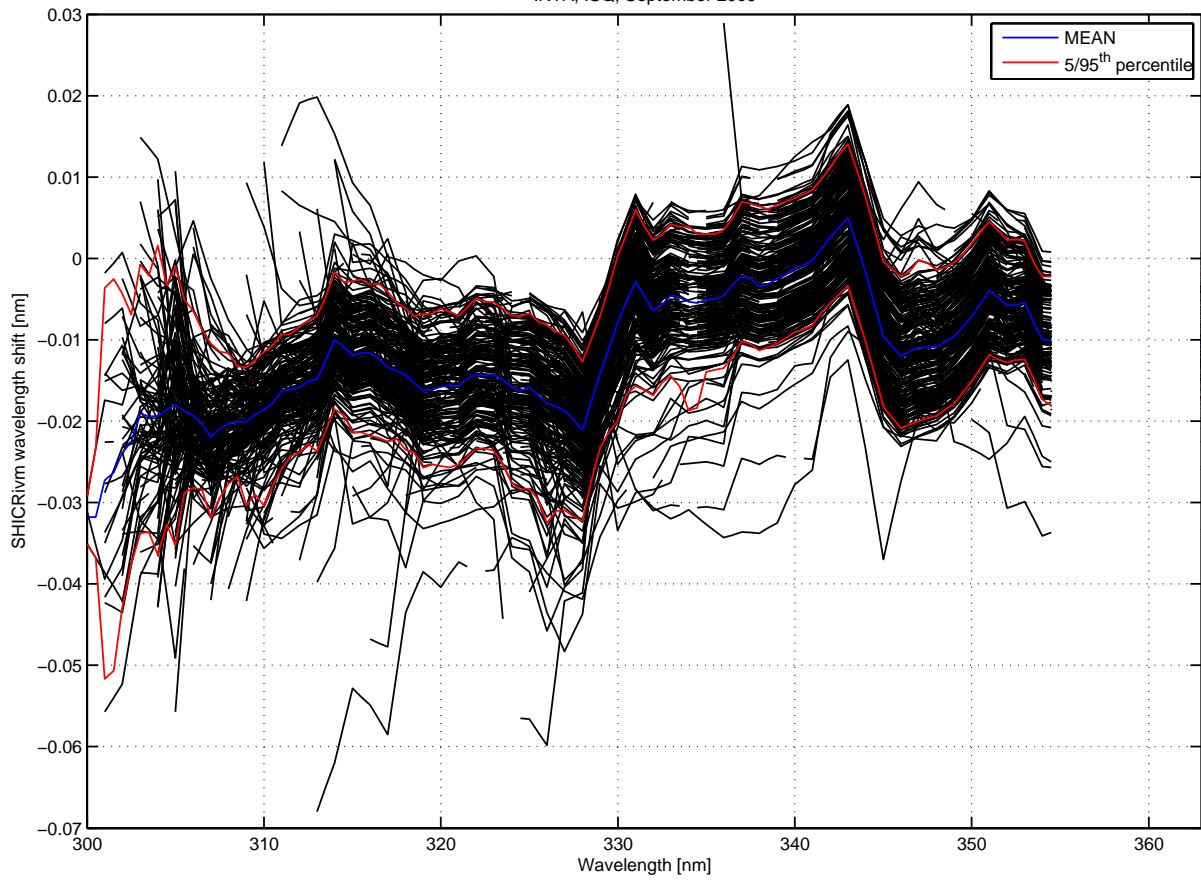

UV Index INTA, September 2009

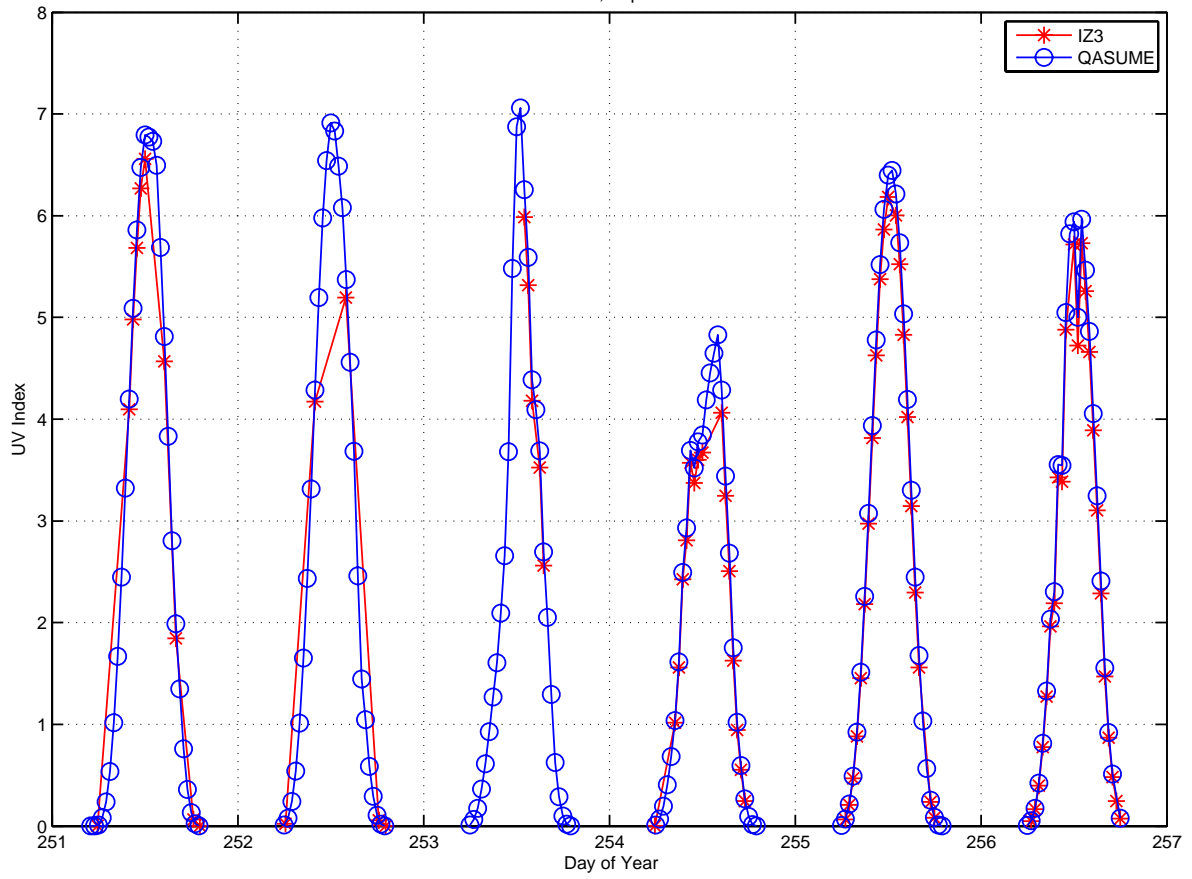

Global irradiance ratios IZ3/QASUME at INTA:08-Sep-2009(251) to 13-Sep-2009(256)

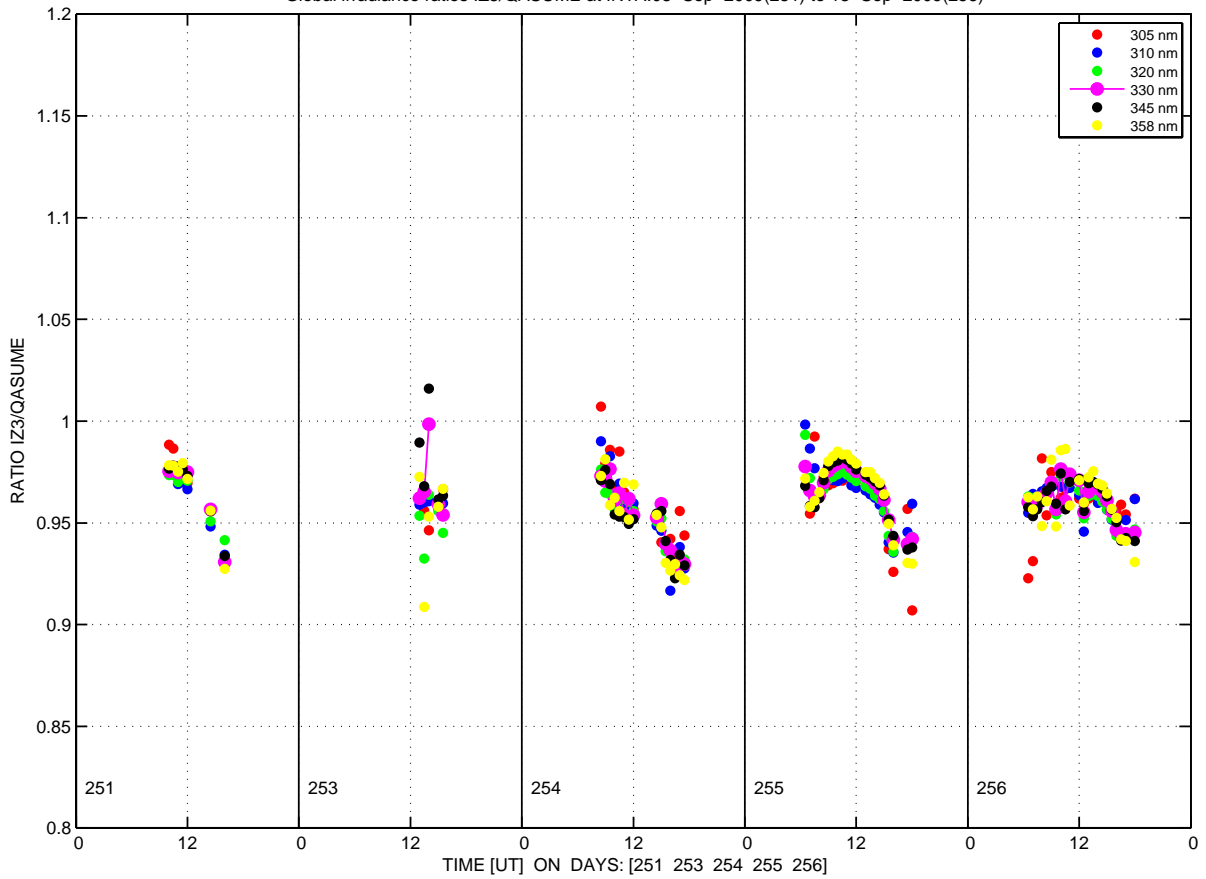

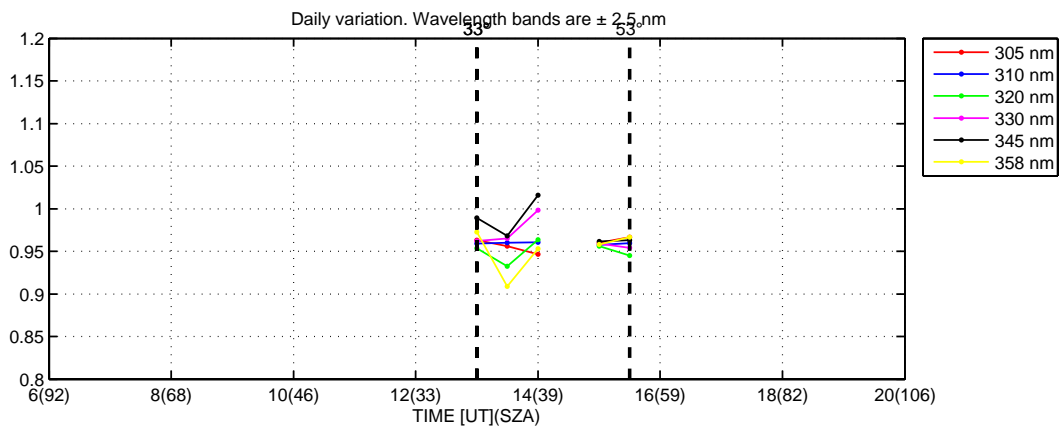
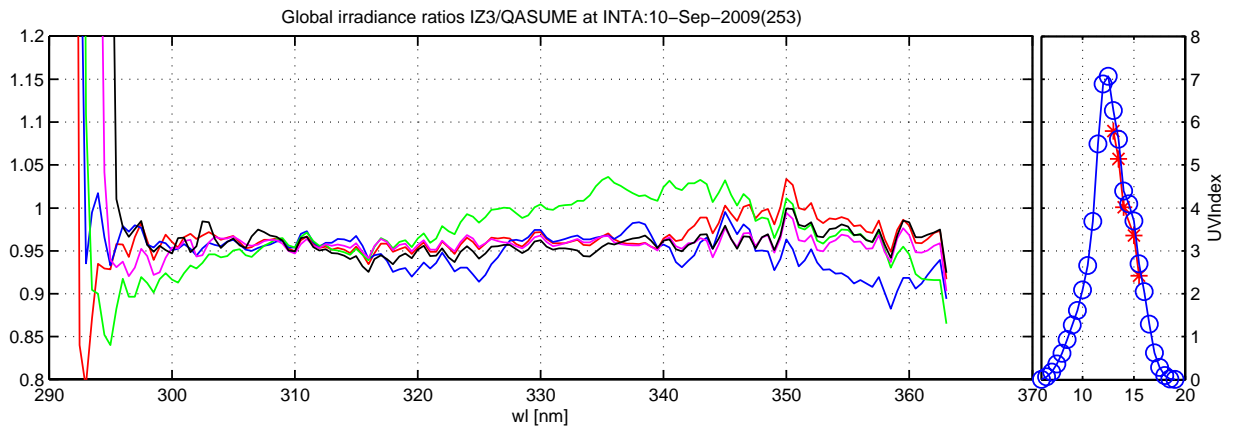
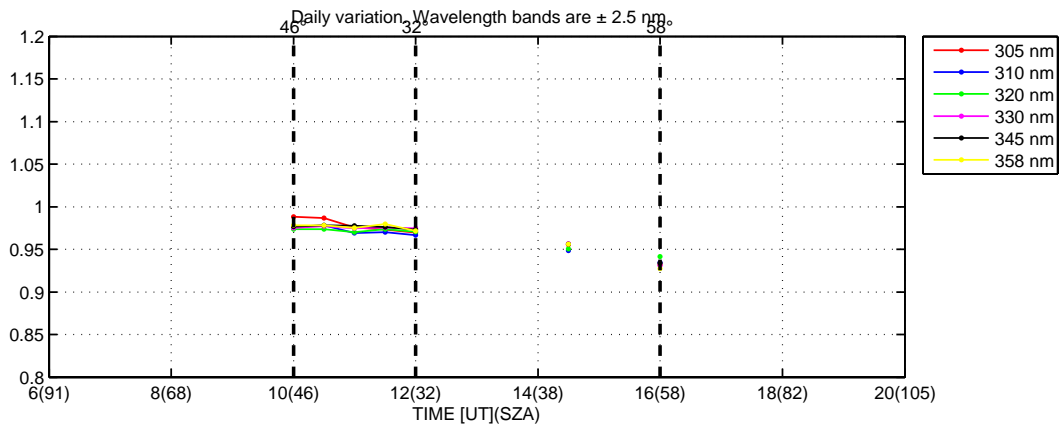
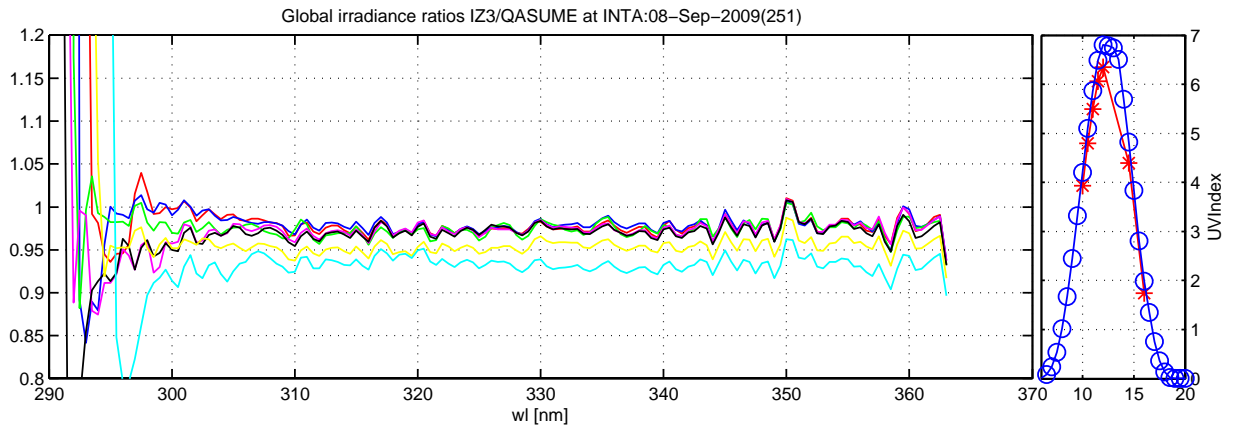

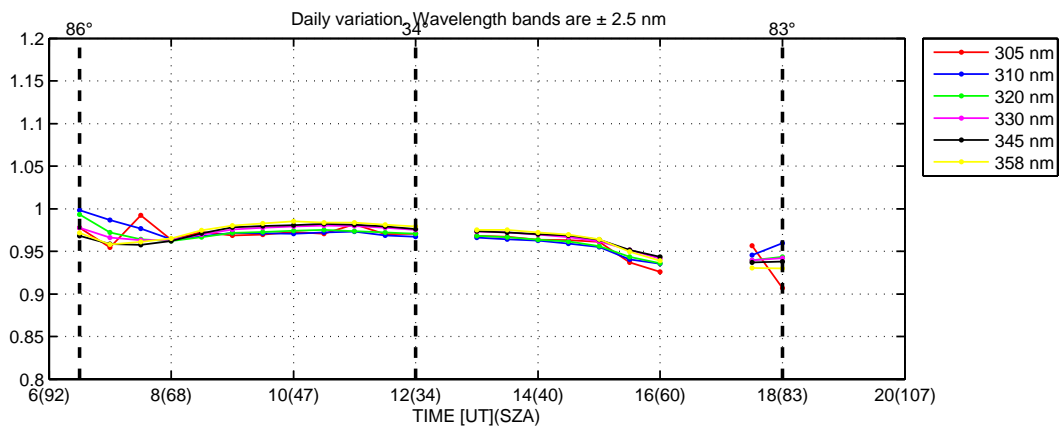
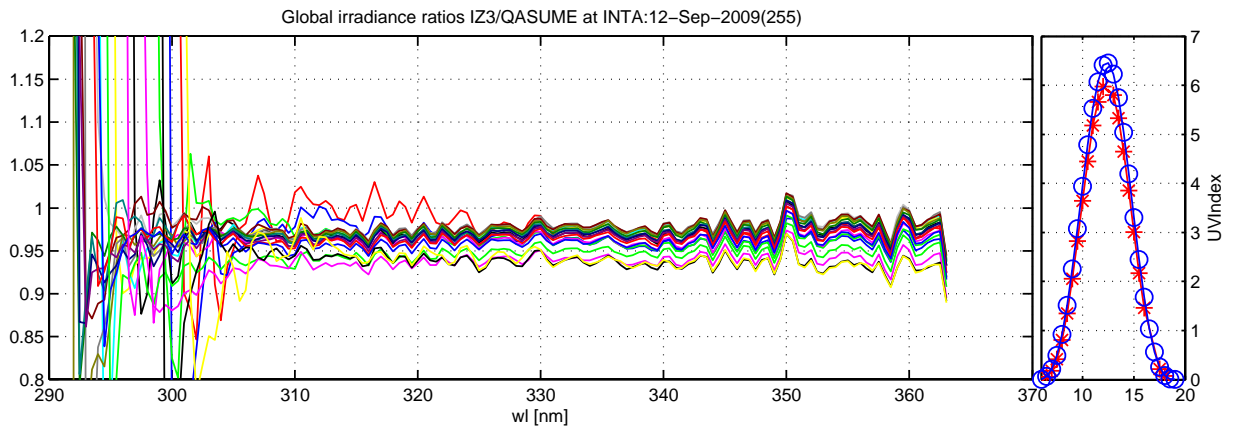
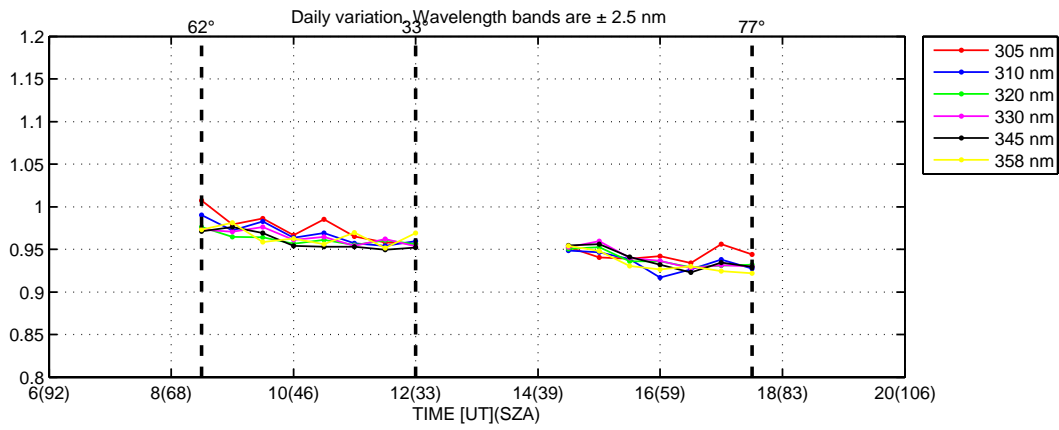
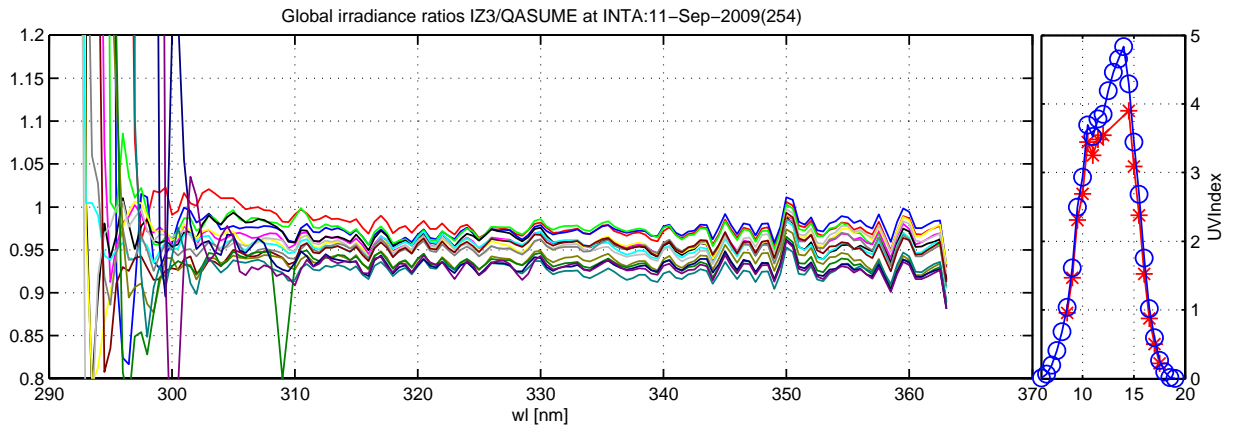

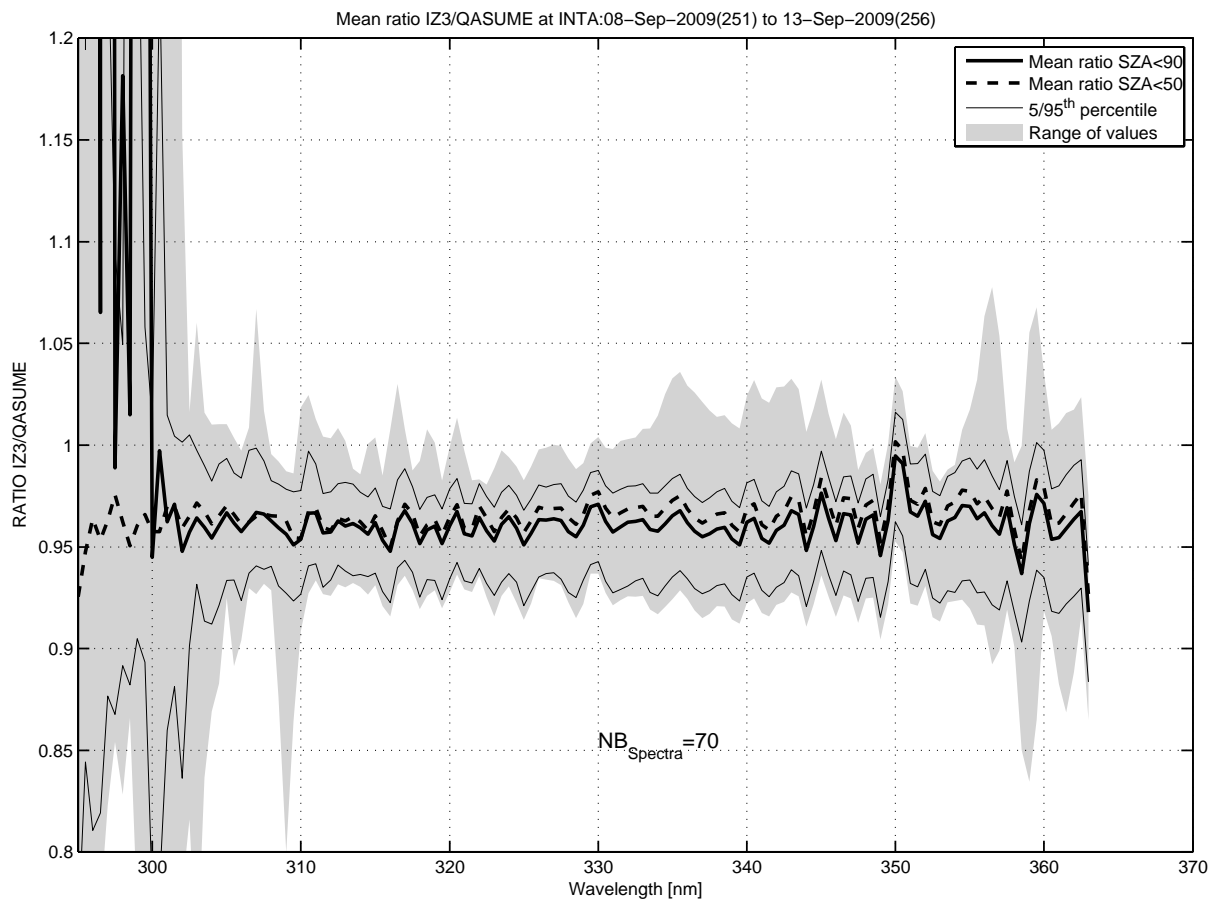
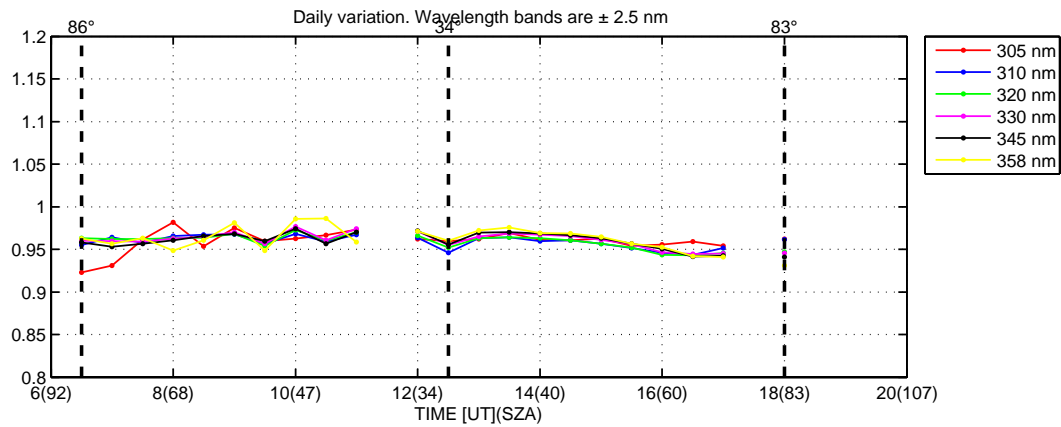
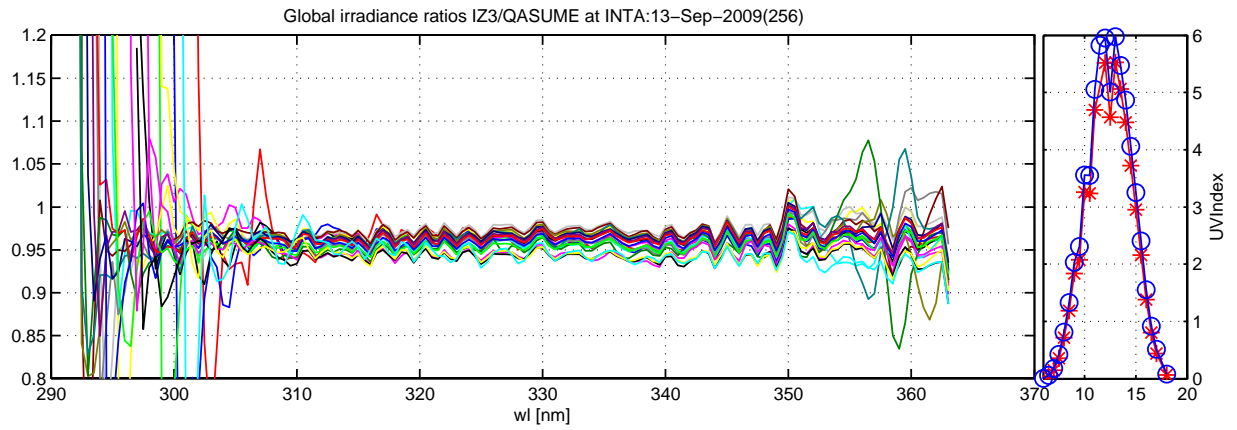

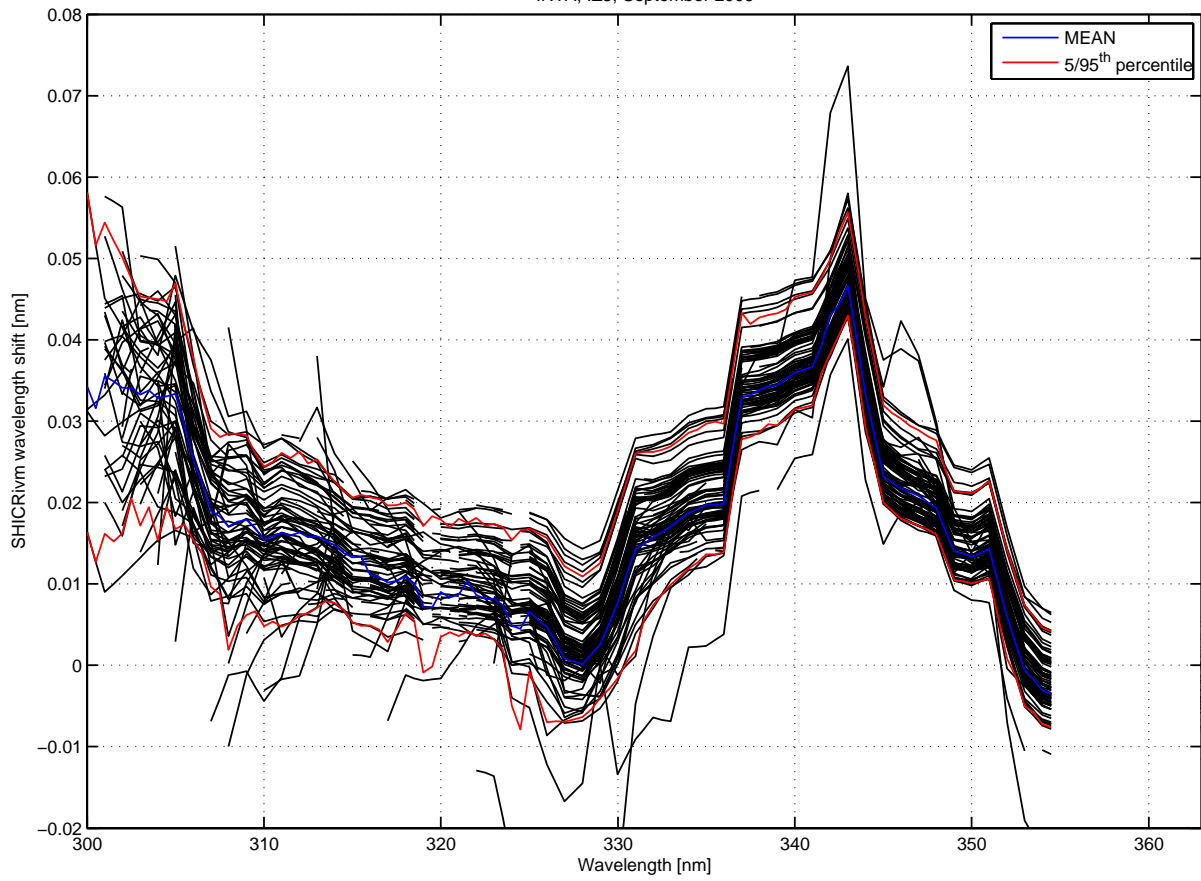



Temperature Dependence of Brewer #017 , INTA, September 2009

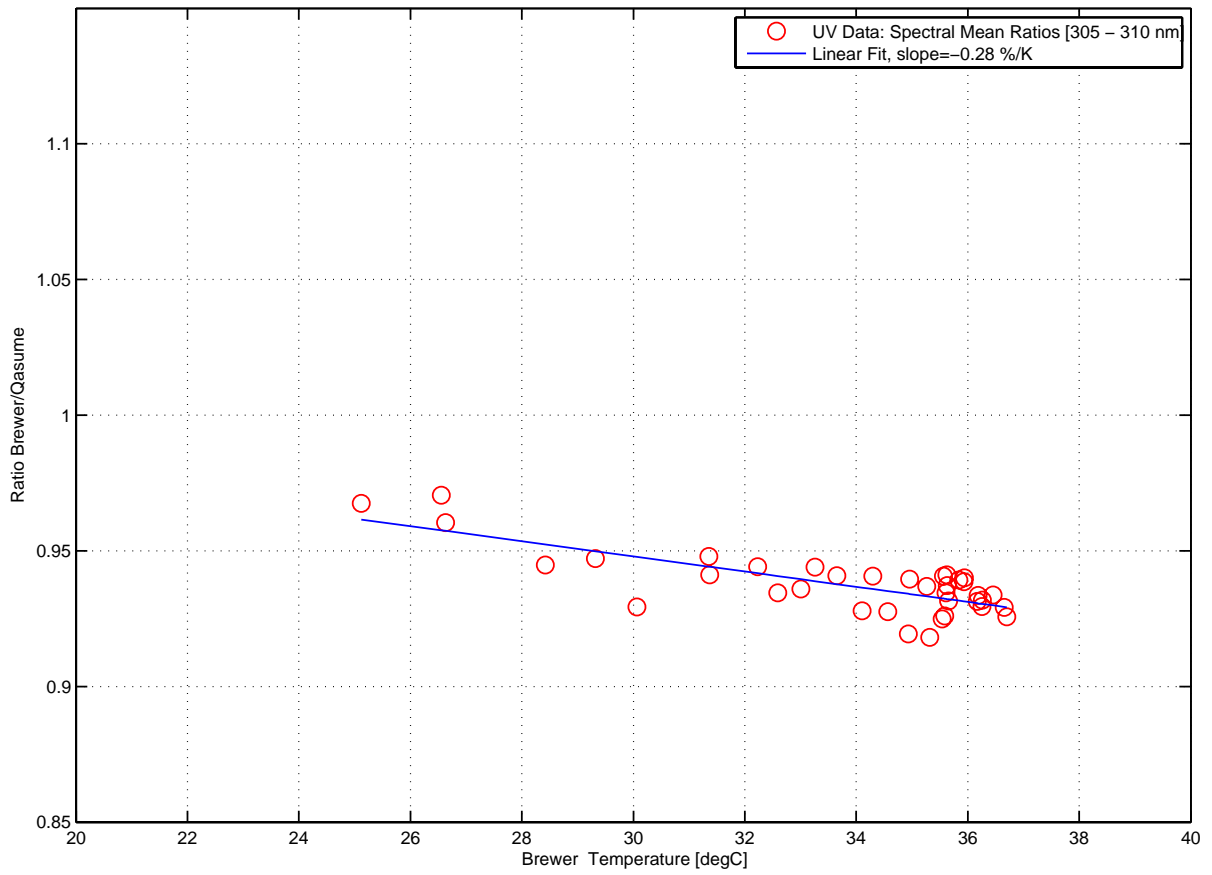

Temperature Dependence of Brewer #051 , INTA, September 2009

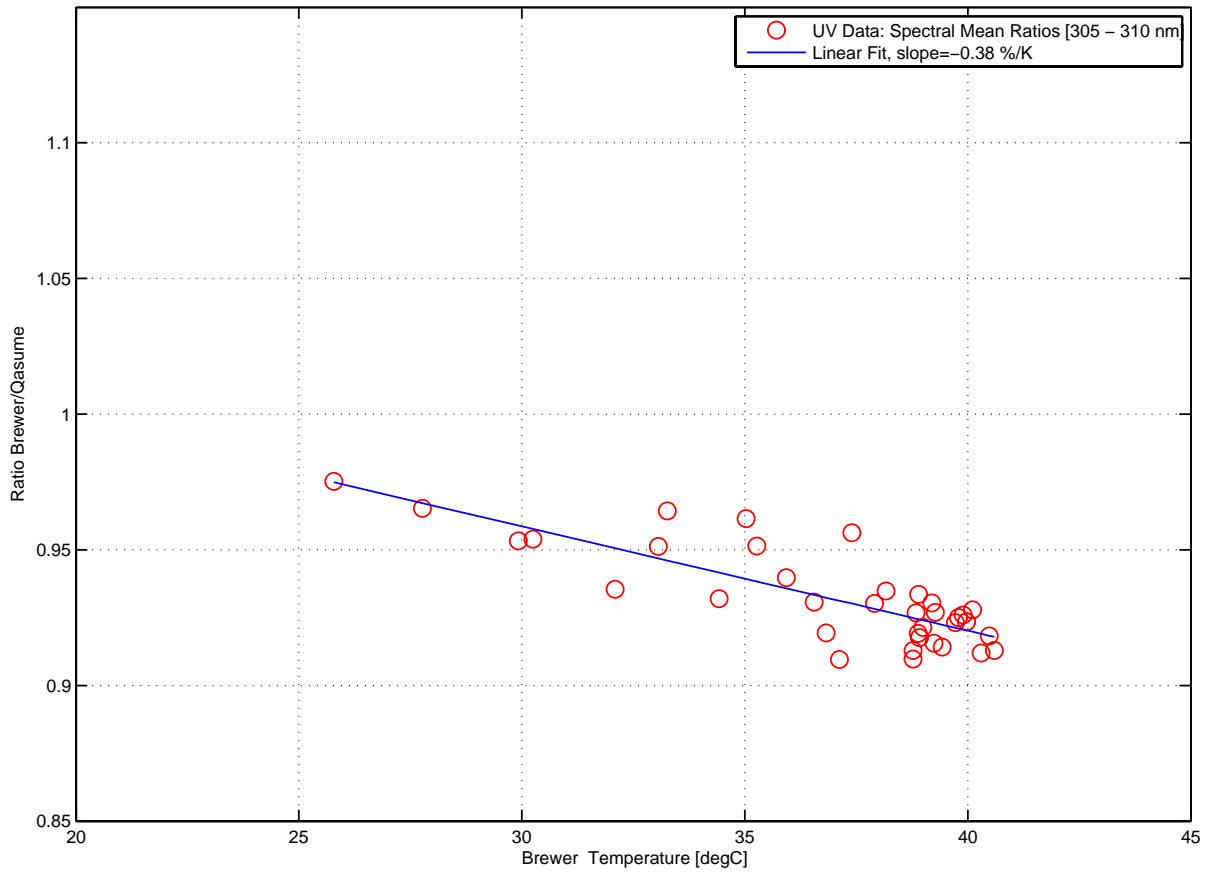

Temperature Dependence of Brewer #070 , INTA, September 2009

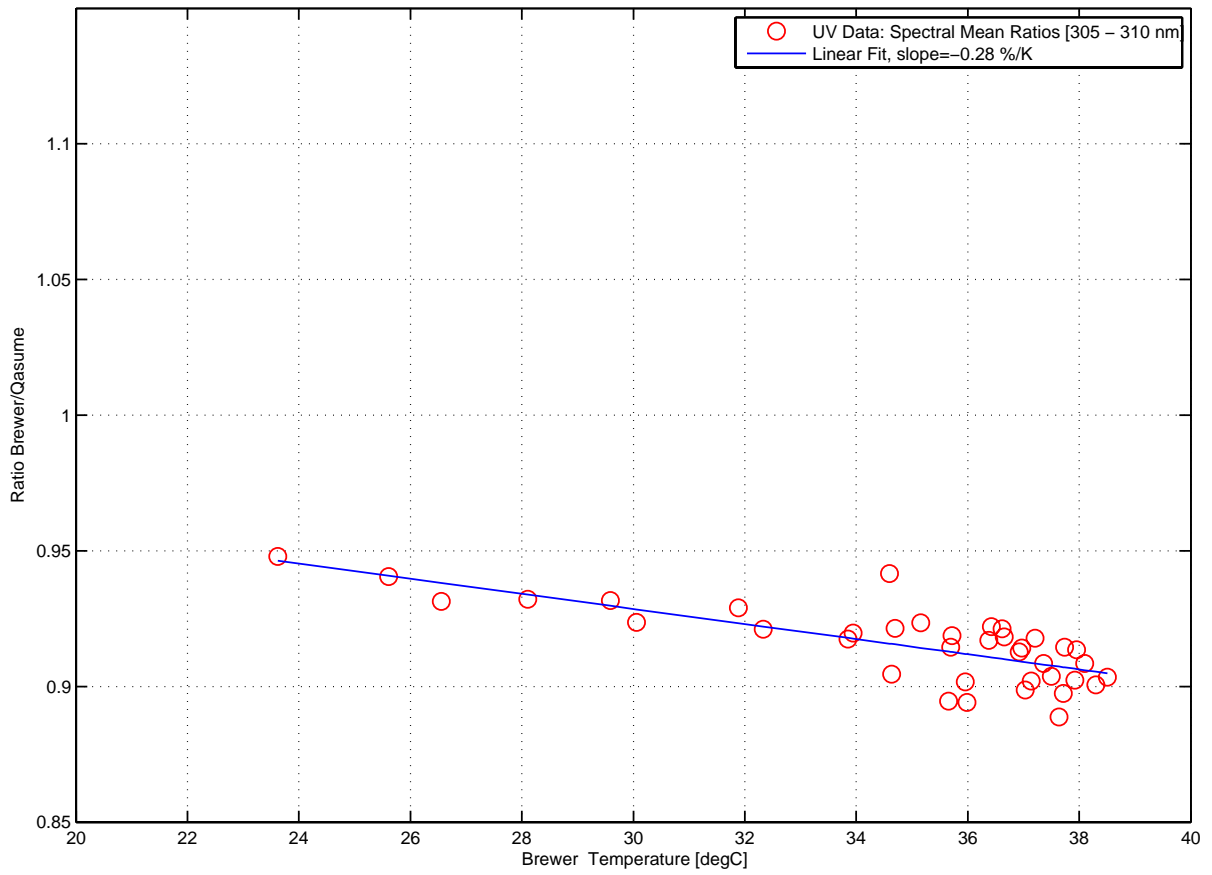

Temperature Dependence of Brewer #075 , INTA, September 2009

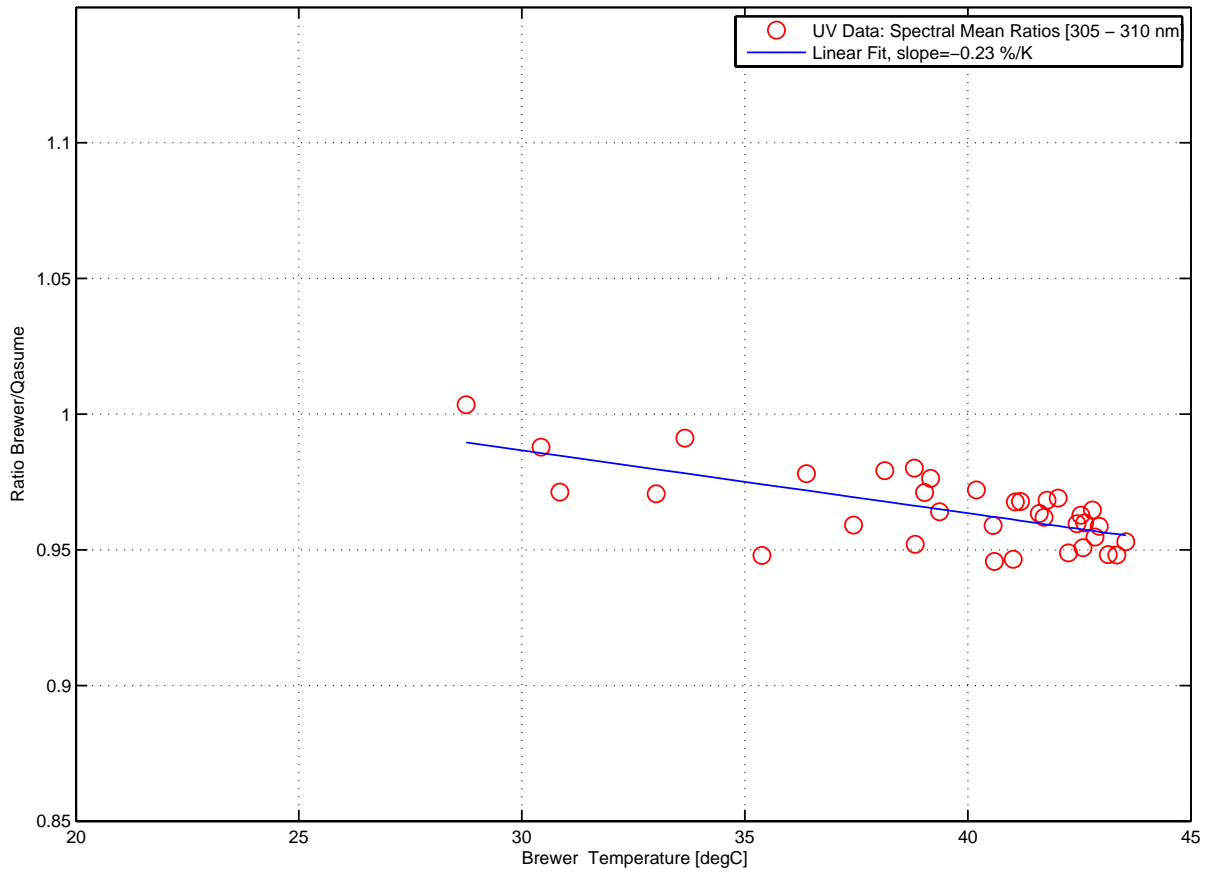

Temperature Dependence of Brewer #117 , INTA, September 2009

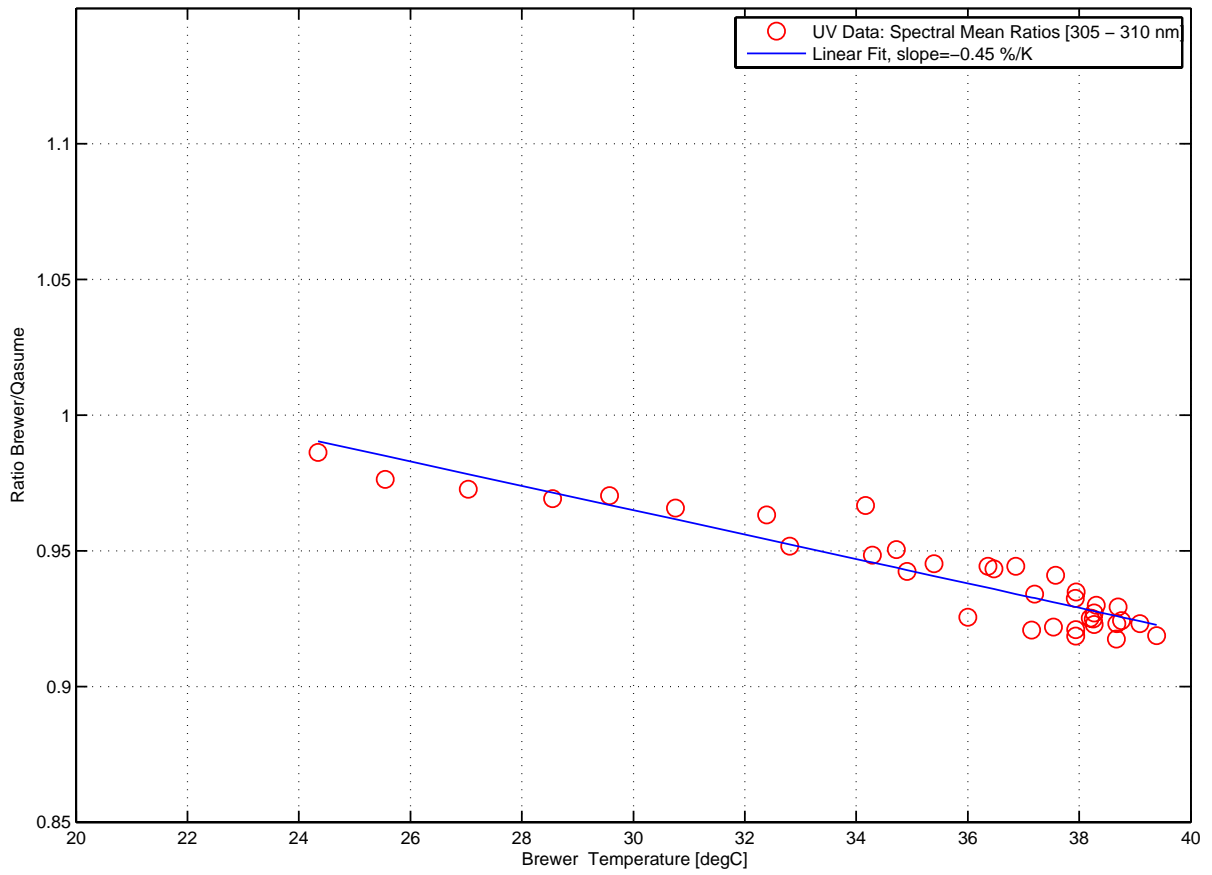

Temperature Dependence of Brewer #126 , INTA, September 2009

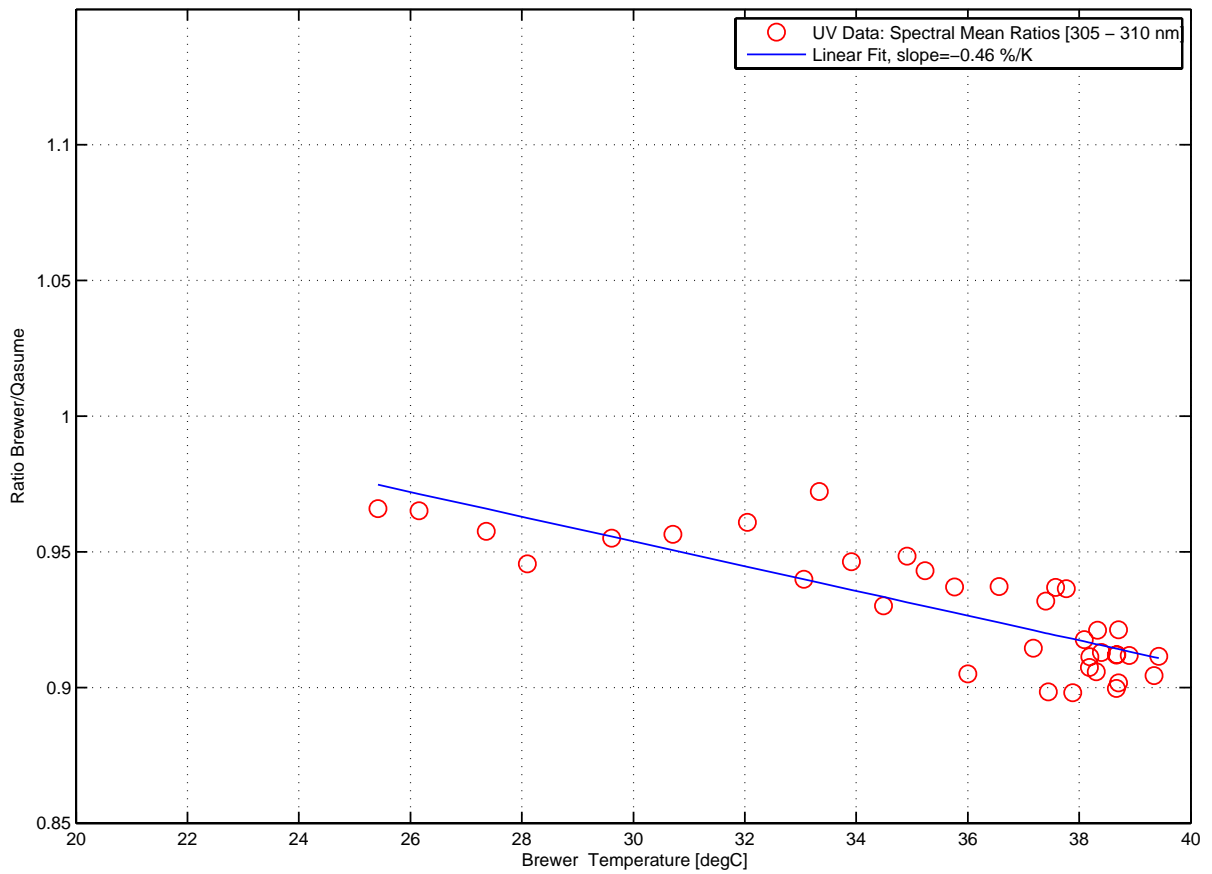

Temperature Dependence of Brewer #145 , INTA, September 2009

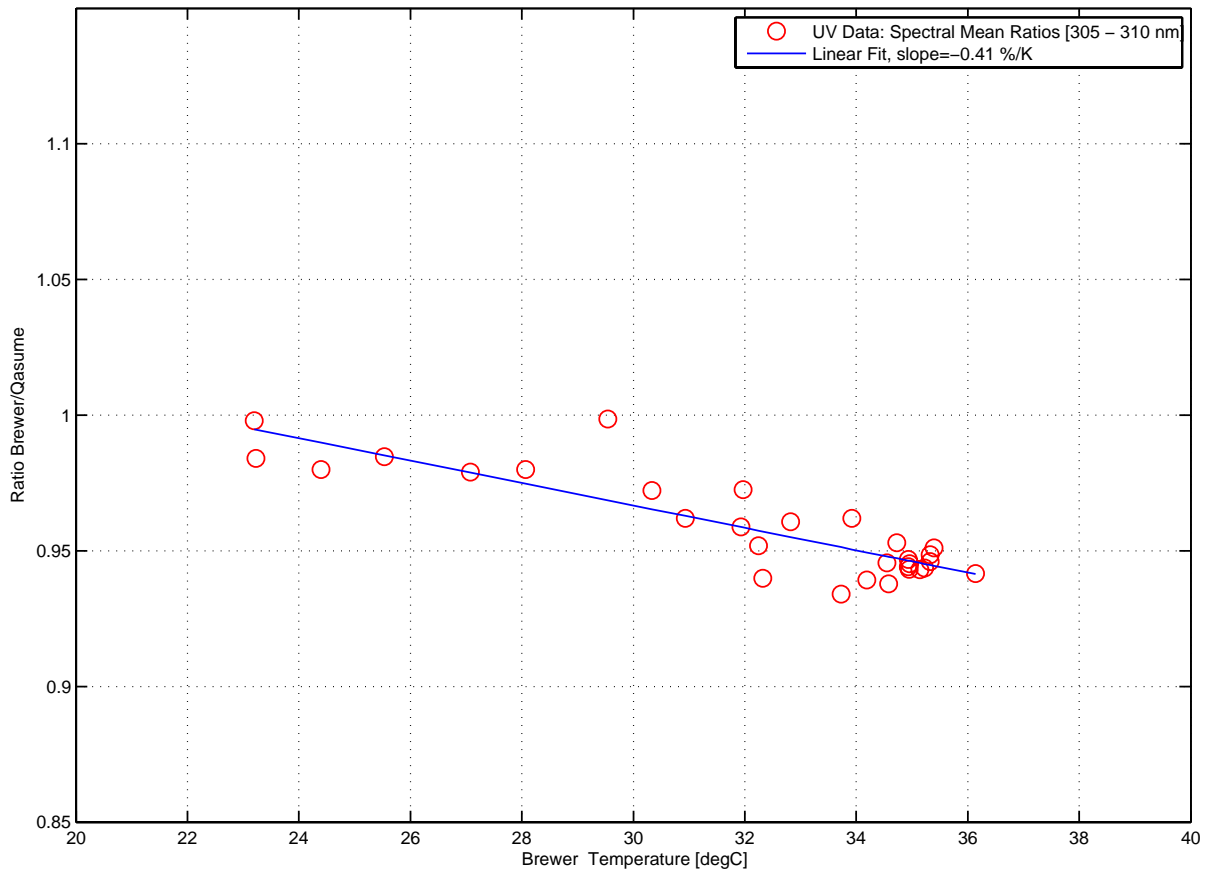

Temperature Dependence of Brewer #150 , INTA, September 2009

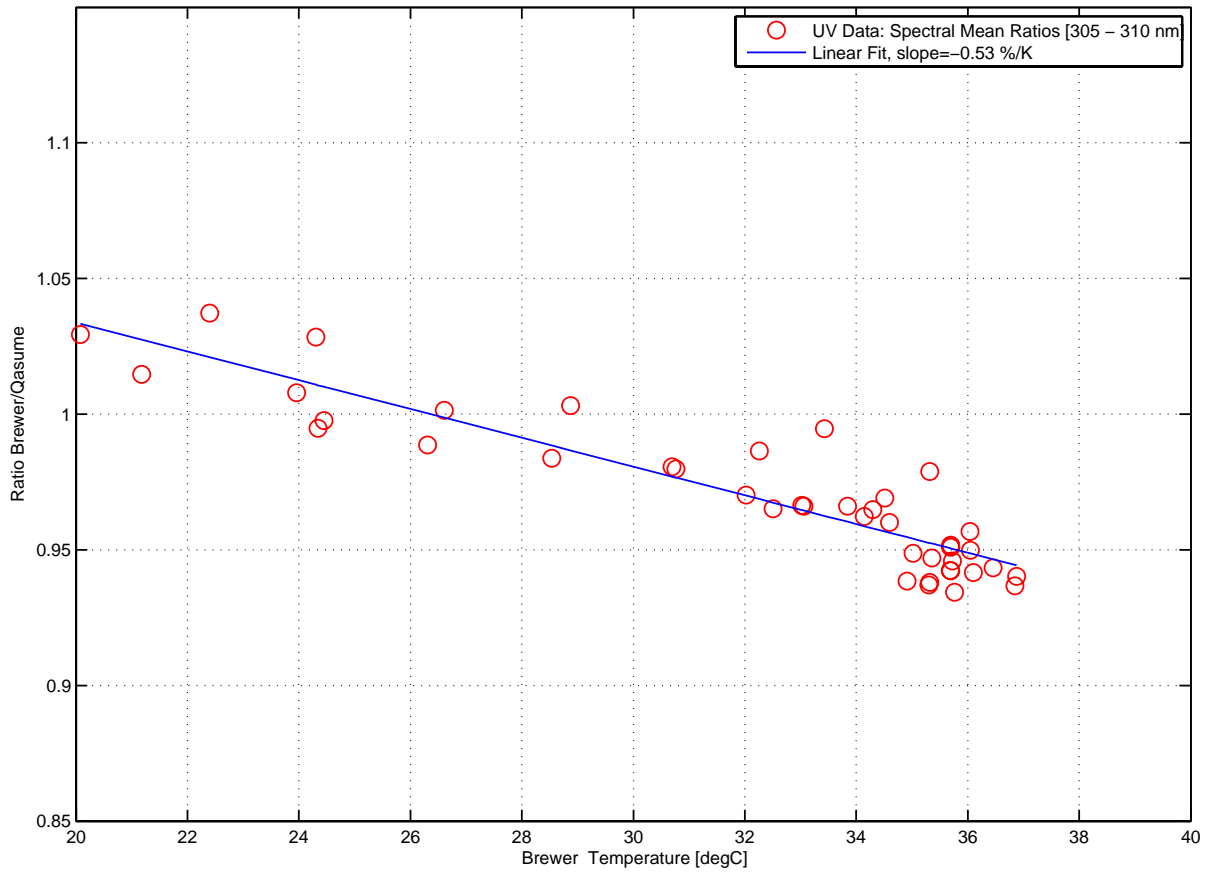

Temperature Dependence of Brewer #151 , INTA, September 2009

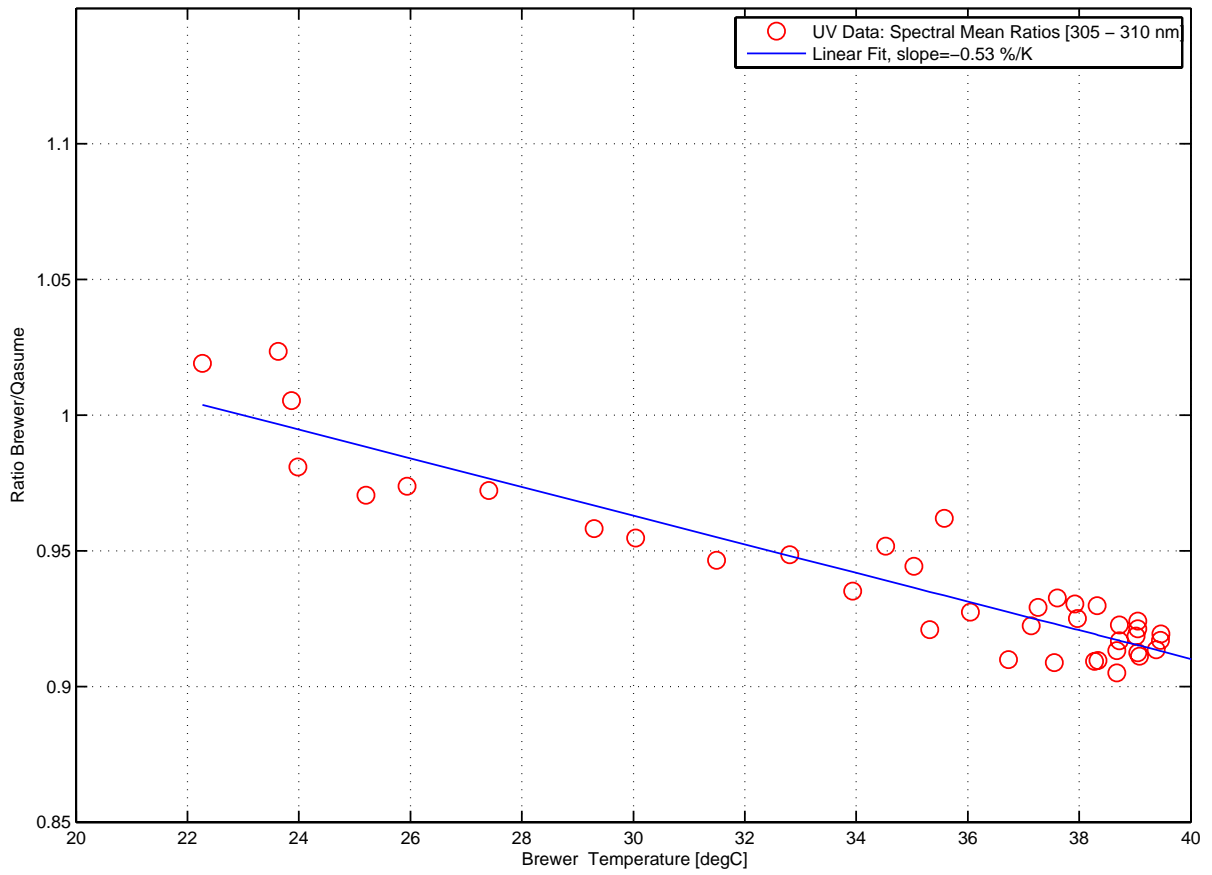

Temperature Dependence of Brewer #158 , INTA, September 2009

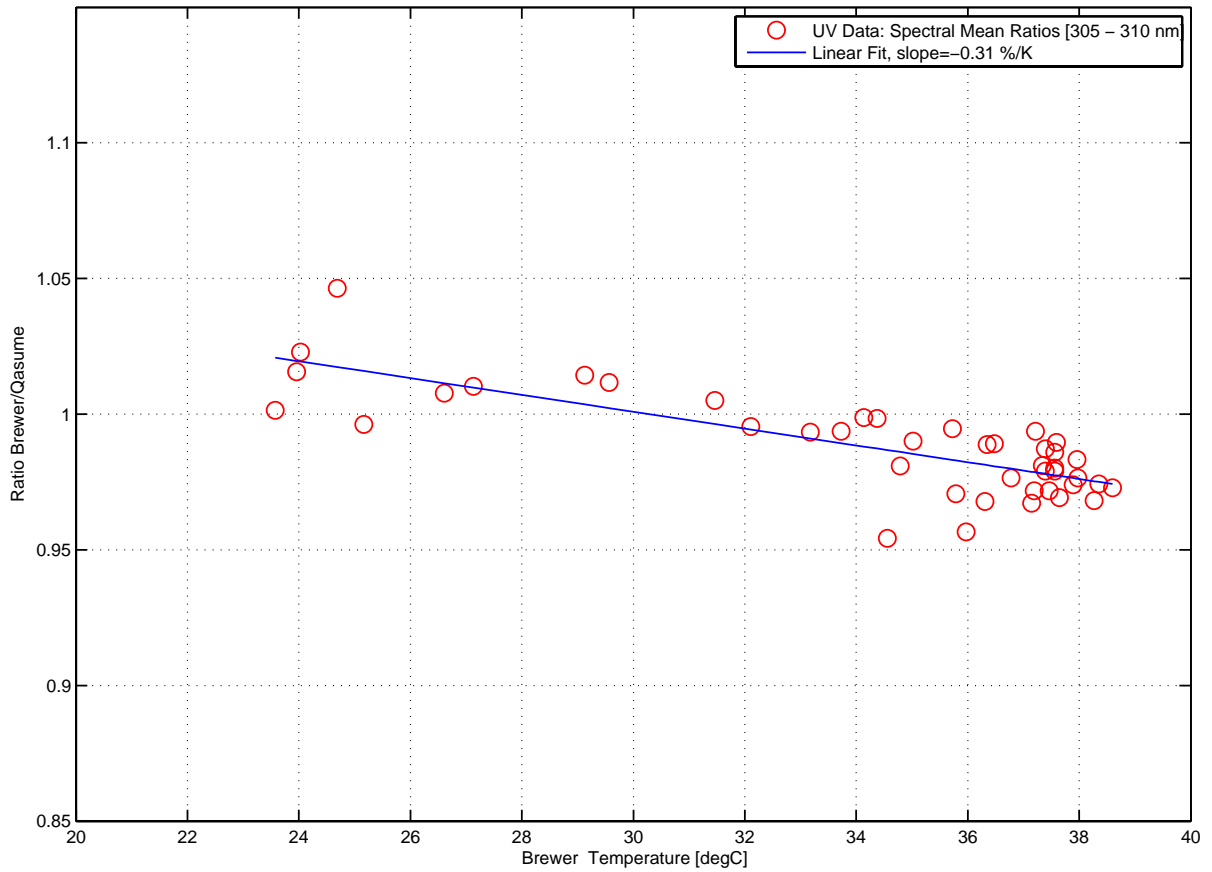

Temperature Dependence of Brewer #165 , INTA, September 2009

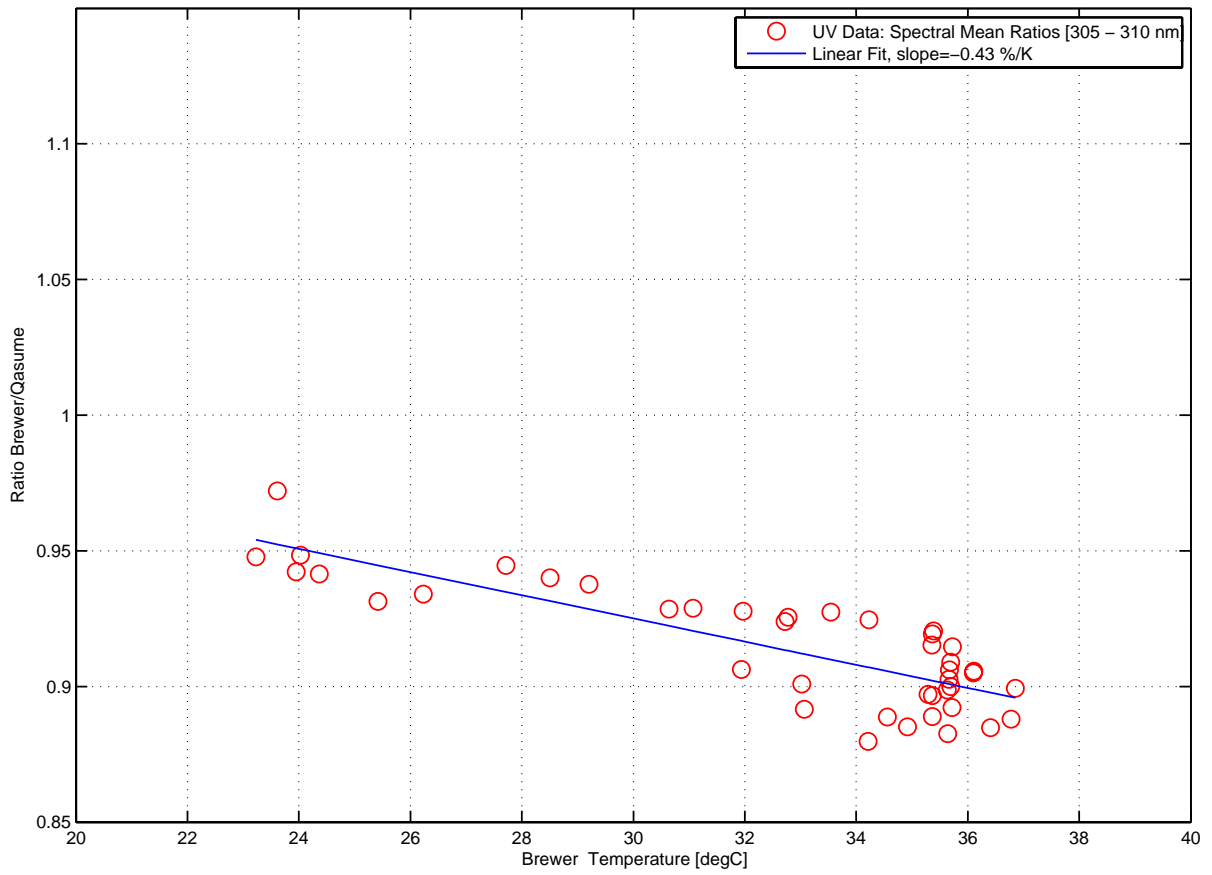

Temperature Dependence of Brewer #166 , INTA, September 2009

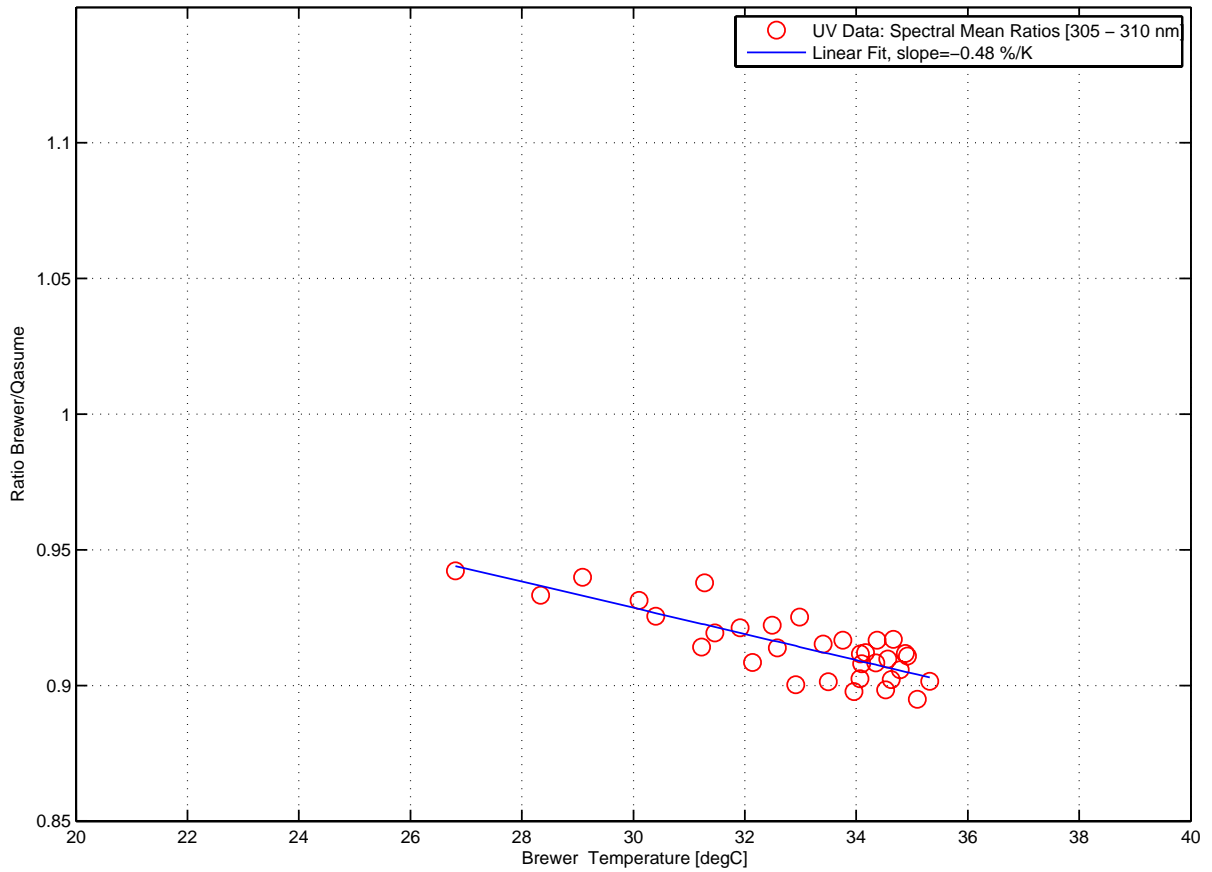

Temperature Dependence of Brewer #172 , INTA, September 2009

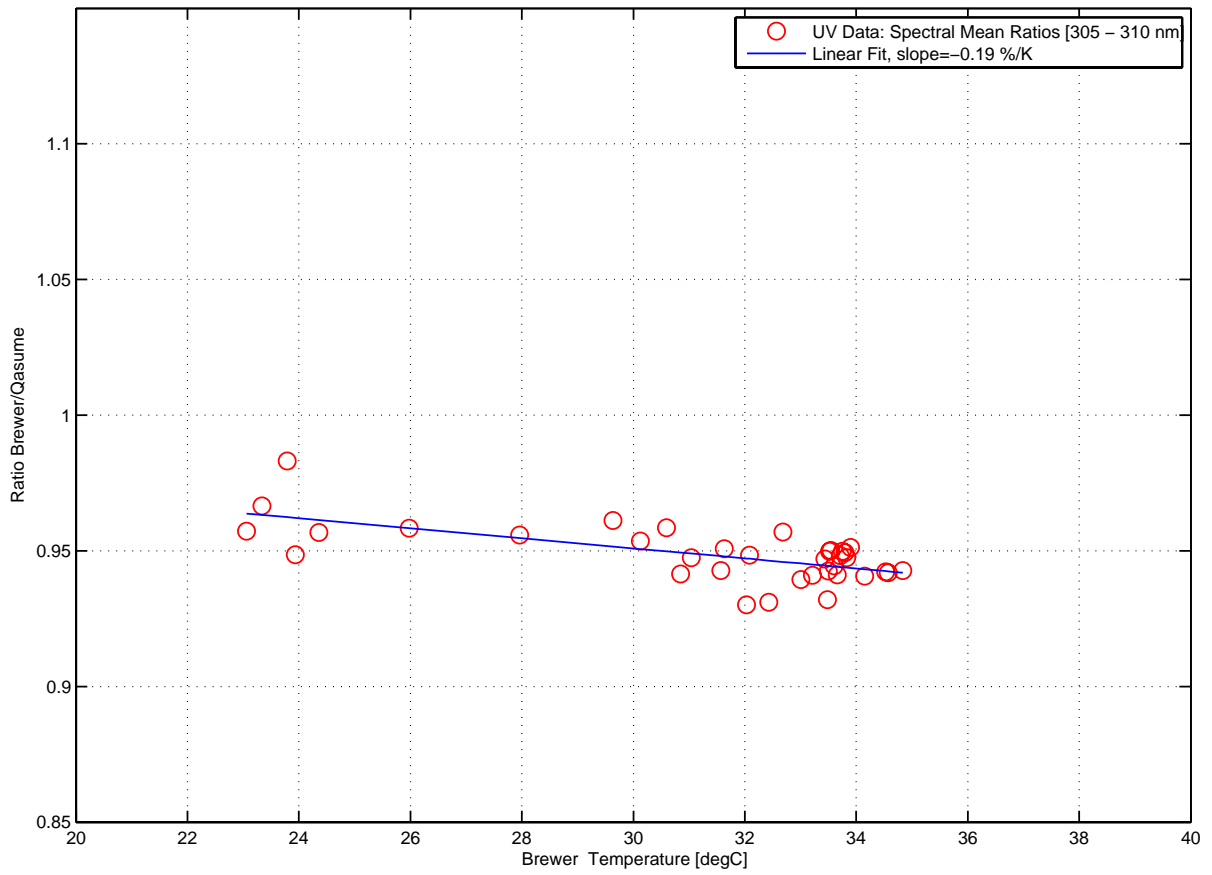

Temperature Dependence of Brewer #185 (IZ3) , INTA, September 2009

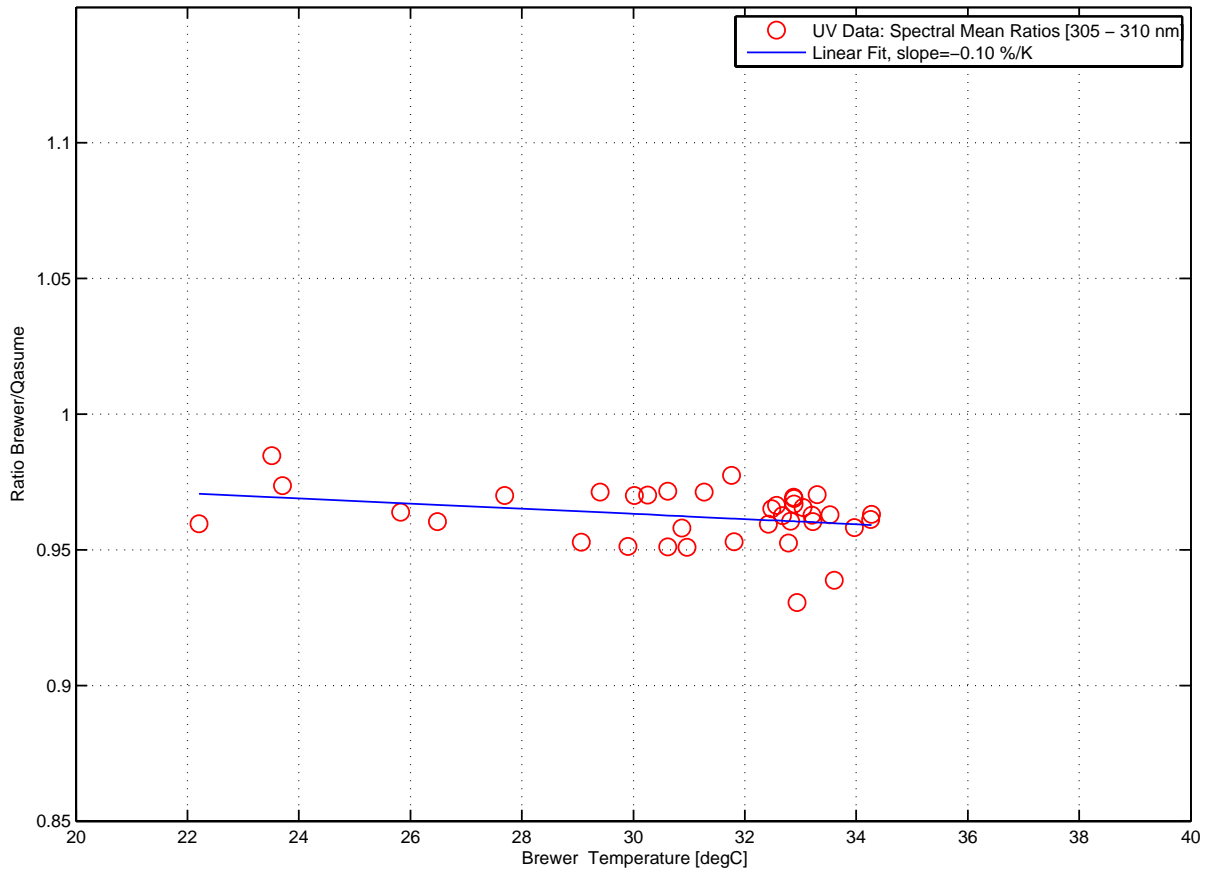

Temperature Dependence of Brewer #186, INTA, September 2009

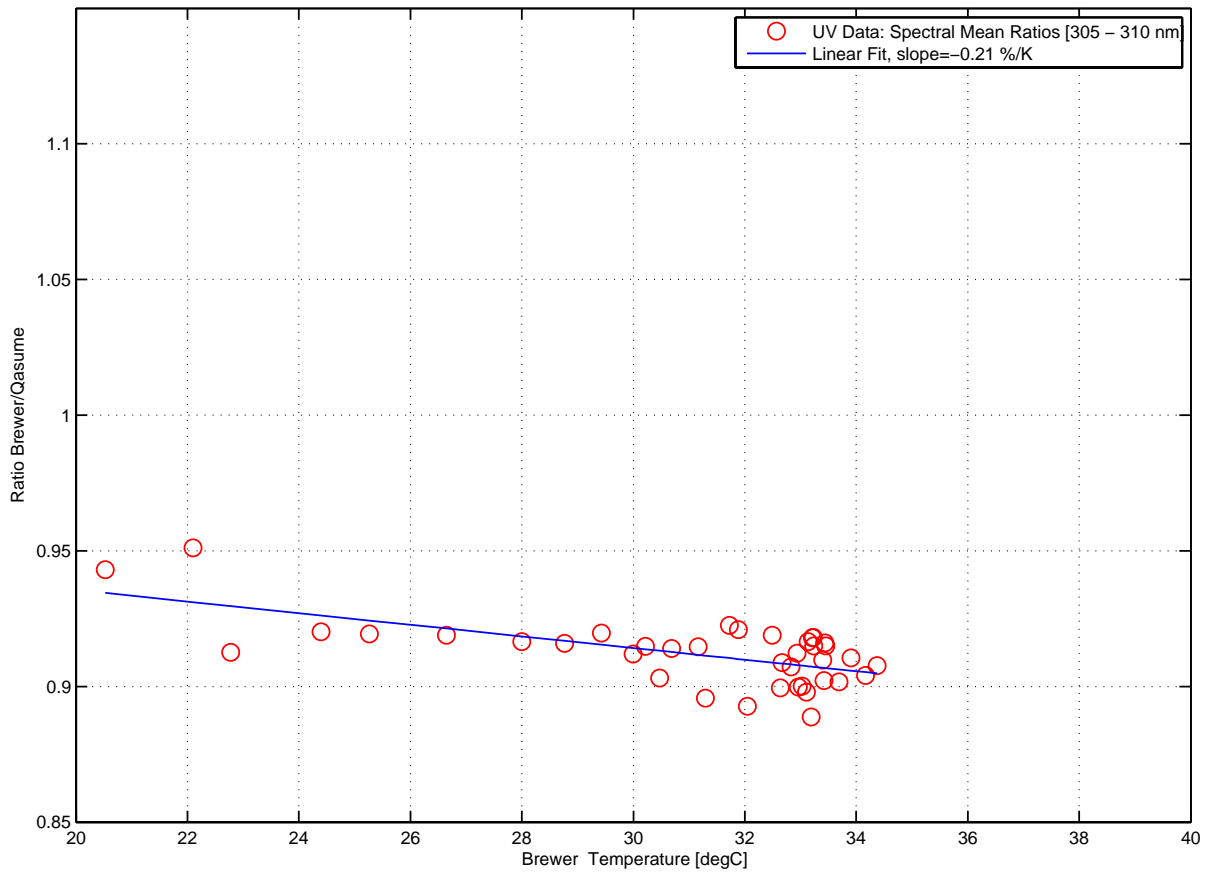

Temperature Dependence of Brewer #197, INTA, September 2009

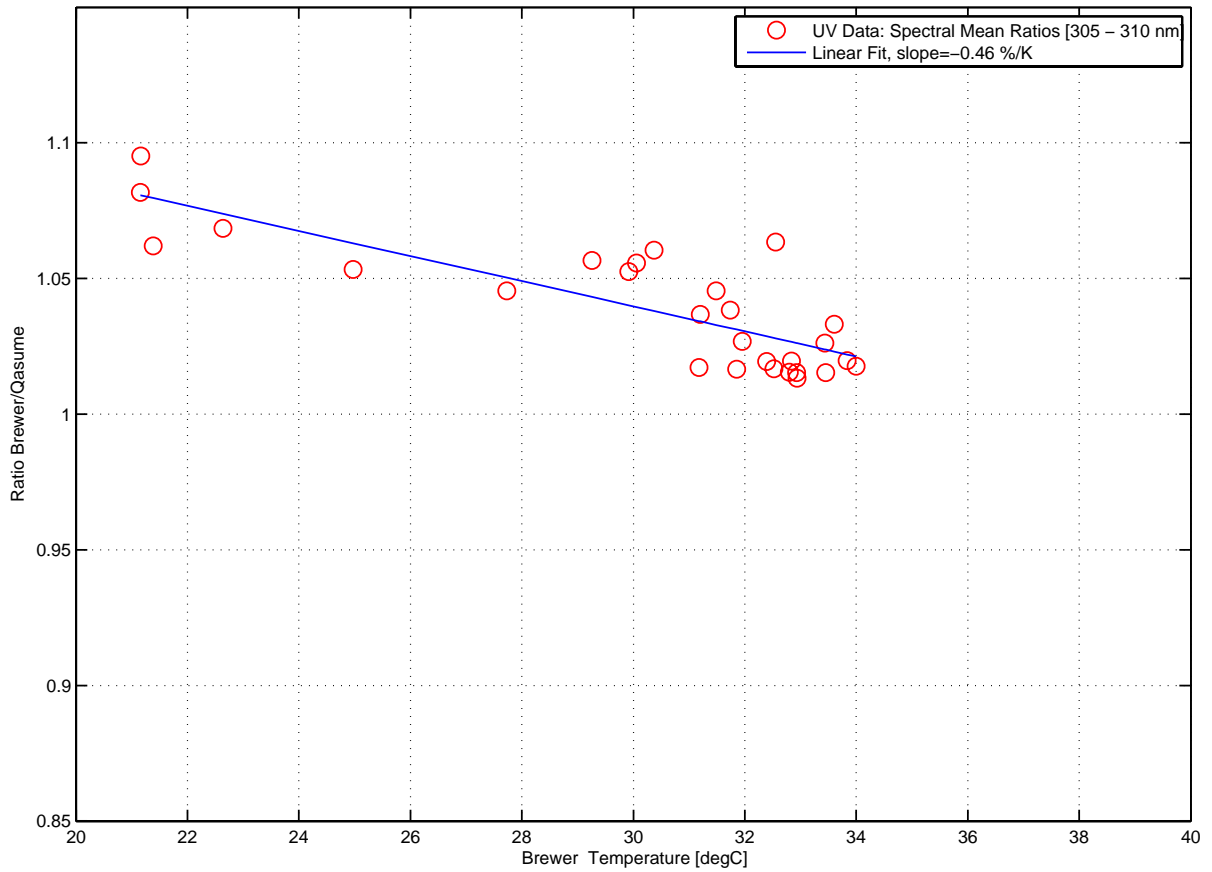



Mean ratios to QASUME for all Brewers at the 4th RBCC-E Campaign, INTA, September 2009

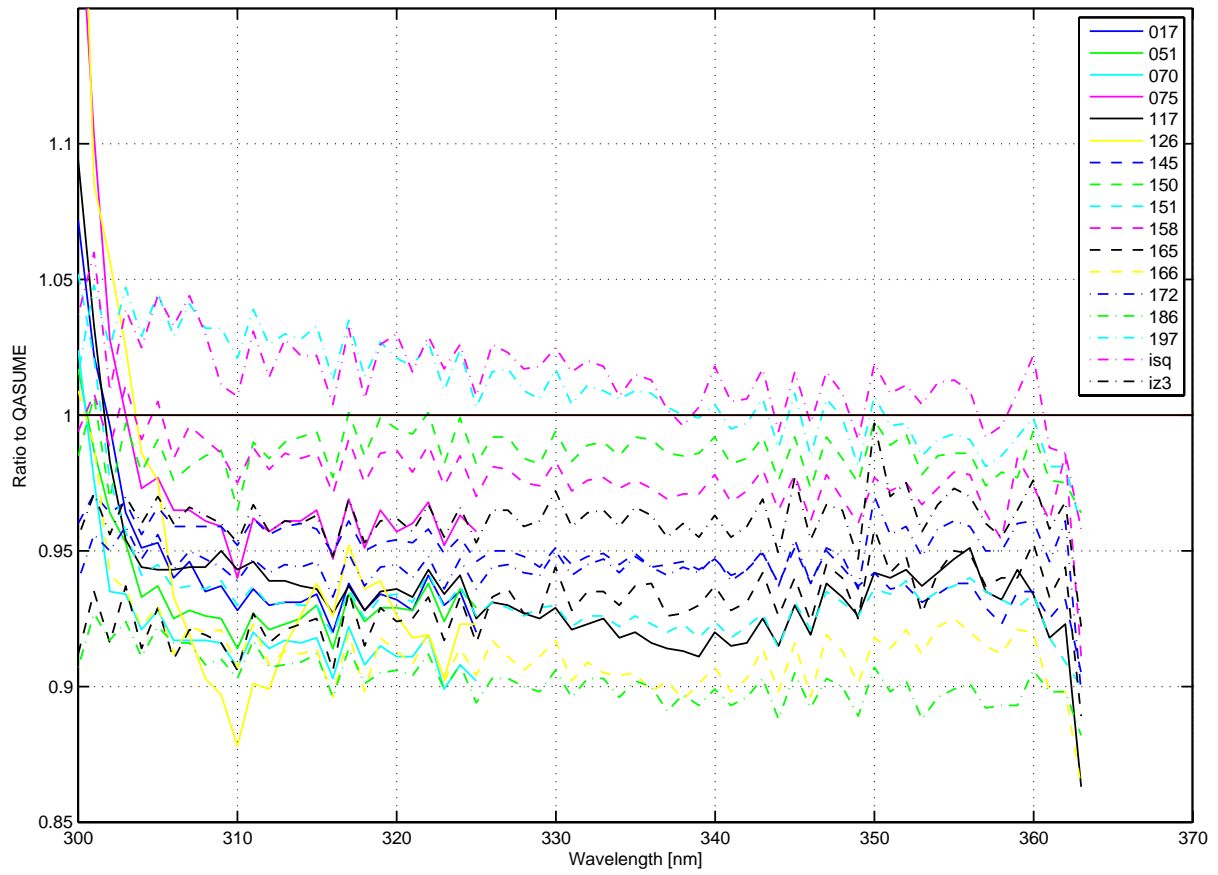

Qasume Responsivity change, INTA, September 2009

